



Discrete direct acting 2 port solenoid valve for oil
(special purpose valve)

FLB Series

- NC (normally closed) type
- Port size: Rc1/8 to Rc1/2



Refer to page 17 in the Ending for details.



JIS symbol

- NC (normally closed) type

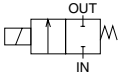

Common specifications

Item	Standard specifications	Optional specifications
Working fluid	Oil (50 mm ² /s or less)	
Working pressure differential range MPa	0 to 1.5	
Withstanding pressure (water) MPa	5.0 (3.0 for orifice ø7/ø10)	
Fluid temperature °C	AC: -10 to 60 DC: -10 to 40 (no freezing)	-10 to 90 (no freezing)
Ambient temperature °C	AC: -20 to 60 DC: -20 to 40	-20 to 60
Heat proof class	B	H or equivalent (AC only)
Atmosphere	Place free of corrosive gas and explosive gas	
Valve structure	Direct acting poppet structure	
Valve seat leakage cm ³ /min.	0 (oil)	
Mounting attitude	Free	
Protective structure	IP65 or equivalent (Note 1)	

Note 1: The T type terminal box type is IP61 or equivalent.

Individual specifications

Item Model no.	Port size	Orifice (mm)	Cv flow factor	Max. working pressure diff. MPa		Max. working pressure MPa	Rated voltage	Rated power (VA)				Power consumption (W)		Weight (kg)					
				AC	DC			Holding		Starting		AC	DC						
NC (normally closed) type																			
FLB21- 6 -Z	Rc1/8	1	0.036	1.5	1.0	1.5	100 VAC 50/60 Hz	6.5	5	9.5	8.5	3.6/2.4		4	0.16				
		-2	2	0.15	0.6			0.25	15.5	10	24	20	6.5/4.0		6	0.30			
FLB31- 6 -3	Rc1/8	3	0.31	0.8	0.5		1.5	110 VAC 60 Hz	22	15	45	40	8.5/6.5		8	0.49			
		-5	4	0.50	0.4				0.15	32	22	65	55	12.5/10.5		11.5	0.68		
FLB41- 8 -5	Rc1/4	4	0.54	0.8	0.45			0.3	200 VAC 50/60 Hz	32	22	65	55	12.5/10.5		11.5	0.68		
		-6	5	0.80	0.5					0.2	32	22	65	55	12.5/10.5		11.5	0.68	
FLB41- 8 -7	Rc3/8	7	1.10	0.2	0.09				0.3	220 VAC 60 Hz	32	22	65	55	12.5/10.5		11.5	0.68	
		-8	10	1.88	0.1						0.04	32	22	65	55	12.5/10.5		11.5	0.68
FLB41- 10 -8	Rc3/8, Rc1/2	10	1.88	0.1	0.04					0.3	24 VDC 12 VDC	32	22	65	55	12.5/10.5		11.5	0.68
		-5	4	0.54	1.1							1.3	32	22	65	55	12.5/10.5		11.5
FLB51- 8 -6	Rc1/4	5	0.80	0.7	0.7	0.3					24 VDC 12 VDC	32	22	65	55	12.5/10.5		11.5	0.68
		-7	7	1.10	0.3							0.25	32	22	65	55	12.5/10.5		11.5
FLB51- 10 -8	Rc3/8, Rc1/2	10	1.88	0.12	0.1		0.3				24 VDC 12 VDC	32	22	65	55	12.5/10.5		11.5	0.68
		-8	10	1.88	0.12							0.1	32	22	65	55	12.5/10.5		11.5

*1: The voltage fluctuation must be within ±10% of the rated voltage.

*2: The leakage current must be less than the values shown below.

*3: 8.6 (W) for 12 VDC.

Leakage current	Voltage	100 VAC	200 VAC	24 VDC	12 VDC
	Model no.	FLB2	3 mA or less	1.5 mA or less	1 mA or less
	FLB3/4/5	6 mA or less	3 mA or less	1 mA or less	2 mA or less

How to order

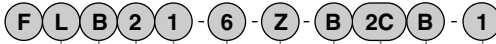

No. of port
(2 port valve)
Working fluid
(oil)

A Size variation

B Actuation

C Port size

D Orifice

*1

*2

E Body/sealant combination

F Coil option

*3

*4

*5

G Other options

H Voltage

*6

Model no.

FLB 21	FLB 31	FLB 41	FLB 51
--------	--------	--------	--------

Symbol Descriptions

A Size variation		FLB 21	FLB 31	FLB 41	FLB 51
2	22 mm	●			
3	28 mm		●		
4	34 mm			●	
5	40 mm				●

B Actuation		FLB 21	FLB 31	FLB 41	FLB 51
1	NC (normally closed) type	●	●	●	●

C Port size		FLB 21	FLB 31	FLB 41	FLB 51
6	Rc1/8	●	●		
8	Rc1/4			●	●
10	Rc3/8			●	●
15	Rc1/2			●	●

D Orifice		FLB 21	FLB 31	FLB 41	FLB 51
Z	ø1	●			
2	ø2	●			
3	ø3		●		
5	ø4			●	●
6	ø5			●	●
7	ø7			●	●
8	ø10			●	●

E Body/sealant combination		FLB 21	FLB 31	FLB 41	FLB 51
B	Body				
	Sealant				
	Brass	●	●	●	●
	FKM	●	●	●	●

F Coil option		FLB 21	FLB 31	FLB 41	FLB 51
2C	Std.	●	●	●	●
	Grommet lead wire	●	●	●	●
2CS	Std.	●	●	●	●
	Grommet lead wire with surge suppressor	●	●	●	●
2G	Std.	●	●	●	●
	DIN terminal box (Pg11)	●	●	●	●
2HS	Std.	●	●	●	●
	DIN terminal box with light and surge suppressor (Pg11)	●	●	●	●
2CG	Option		●	●	●
	Conduit (CTC19)		●	●	●
2CH	Option		●	●	●
	Conduit (G1/2)		●	●	●
3T	Option		●	●	●
	T type terminal box (G1/2)		●	●	●
3RS	Option		●	●	●
	DIN terminal box with light and surge suppressor (G1/2)		●	●	●
4A	Option		●	●	●
	Grommet lead wire (heat proof class H)		●	●	●

G Other options		FLB 21	FLB 31	FLB 41	FLB 51
Blank	Std.	●	●	●	●
	None				
B	Option	●	●	●	●
	Mounting plate	●	●	●	●

H Voltage		FLB 21	FLB 31	FLB 41	FLB 51
1	100 VAC 50/60 Hz, 110 VAC 60 Hz	●	●	●	●
2	200 VAC 50/60 Hz, 220 VAC 60 Hz	●	●	●	●
3	24 VDC	●	●	●	●
4	12 VDC	●	●	●	●

For voltages other than above, directly write in the voltage.
Select from the combinations indicated with ● above.

<Example of model number>

FLB21-6-Z-B2CB-1
Model no.: FLB

- A** Size variation: 22 mm
- B** Actuation: NC (normally closed) type
- C** Port size: Rc1/8
- D** Orifice: ø1
- E** Body/sealant combination:
Body - brass, sealant - FKM
- F** Coil option: Grommet lead wire
- G** Other options: Mounting plate
- H** Voltage: 100 VAC 50/60Hz, 110 VAC 60Hz

⚠ Note on model no. selection

- *1: For FLB41/51 orifice ø4 mm (D 5), ø5 mm (D 6) and ø7 mm (D 7), only bore sizes Rc1/4 (C 8) and Rc3/8 (C 10) are available.
- *2: For orifice ø10 mm (D 8), port sizes Rc3/8 (C 10) and Rc1/2 (C 15) are available. The body is bronze casting.
- *3: For FLB21 2G/2HS, the compact terminal box (Pg9) is used.
- *4: For 2CS, the surge suppressor is built into the coil, and for 2HS/3RS, it is built into the terminal box.
- *5: High-temperature specifications (fluid temperature 90°C) are available only for coil option 4A. Grommet lead wire (heat proof class H) (F 4A) is available only for AC.
- *6: Some voltages are not available. Contact CKD for details.

HNB/G

USB/G

FAB/G

FGB/G

FVB

FWB/G

FHB

FLB

AB

AG

AP/AD

APK/ADK

For dry air

Explosion proof

HVB/HVL

SAB/SVB

NP/NAP/NVP

CHB/G

MXB/G

Other G.P. systems

PD/FAD/PJ

CVE/ CVSE

CPE/CPD

Medical analysis

Custom order

Special purpose valve for oil

Direct-acting 2 port solenoid valve

Internal structure and parts list

● FLB*1 Series

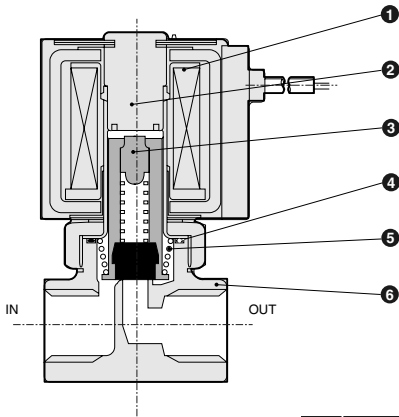

No.	Parts name	Material	
1	Coil assembly	–	–
2	Core assembly	SUS, Cu	Stainless steel, copper
3	Plunger assembly	SUS, C3604, FKM	Stainless steel, brass, fluoro rubber
4	O ring	FKM	Fluoro rubber
5	Spring	SUS	Stainless steel
6	Body	C3771 or CAC407	Brass or bronze

Dimensions (Page 116)

● Grommet lead wire type
FLB*1-**-B2C

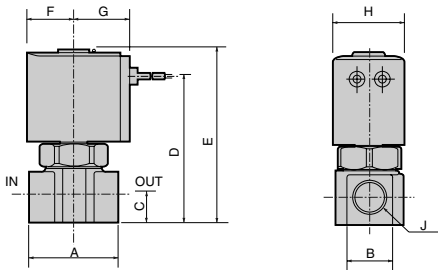

Lead wire length 300 mm

Model no.	A	B	C	D	E	F	G	H	J	K	L
FLB21	32	14	8	45.5	56	15.5	19.5	22	Rc1/8	15	M4 depth 6
FLB31	36	18	11	57.5	68.5	18.5	22.5	28	Rc1/8, Rc1/4	18	M5 depth 6
FLB41	40	21	12	67	81	22.5	26	34	Rc1/4, Rc3/8	18	M5 depth 8
FLB41-10/15-8 (office of 10)	50	29	15	76	90				Rc3/8, Rc1/2		
FLB51	40	21	12	73.5	89	26	29.5	40	Rc1/4, Rc3/8	18	M5 depth 8
FLB51-10/15-8 (office of 10)	50	29	15	82.5	98				Rc3/8, Rc1/2		

Optional dimensions



(Page 116)

(Refer to the grommet lead wire type dimensions on the left page for common dimensions.)

- Grommet lead wire with surge suppressor
FLB*1-**-B **2CS**

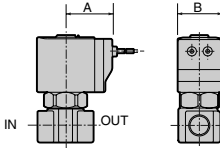

Model no.	A	B
FLB21	26.5	22
FLB31	29.5	28
FLB41	34	34
FLB51	37.5	40

- DIN terminal box (with light and surge suppressor)
FLB*1-**-B **2G**
2HS

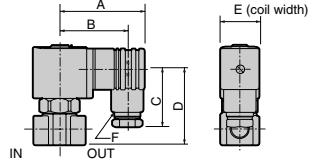

Model no.	A	B	C	D	E	F
FLB21	53	44	38	39	22	Pg 9
FLB31	58.5	47	39	51	28	Pg11
FLB41 FLB41-10/15-8 (orifice ø10)	62	50.5	39	61 70	34	Pg11
FLB51 FLB51-10/15-8 (orifice ø10)	65.5	54	39	69.5 78.5	40	Pg11

- Conduit (CTC19, G1/2)
FLB*1-**-B **2CG**
2CH

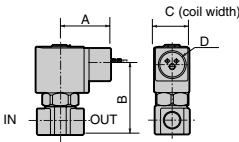

Model no.	A	B	C	D	E
FLB31	92	60.5	53	79	28
FLB41 FLB41-10/15-8 (orifice ø10)	96.5	64.5	62.5 71.5	88.5 97.5	34
FLB51 FLB51-10/15-8 (orifice ø10)	99.5	68	71 80	97 106	40

- T type terminal box (with light and surge suppressor) (G1/2)
FLB*1-**-B **3T**
3RS

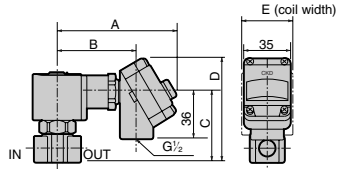

Model no.	A	B	C	D
FLB31	39	52.5	28	CTC19 G1/2
FLB41 FLB41-10/15-8 (orifice ø10)	43	62.5 71.5	34	CTC19 G1/2
FLB51 FLB51-10/15-8 (orifice ø10)	46.5	71 80	40	CTC19 G1/2

- Grommet lead wire (heat proof class H)
FLB*1-**-B **4A**

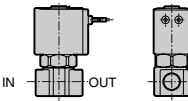

- Mounting plate
FLB*1-**-B **4B**

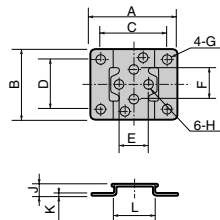

Dimensions are the same as for grommet lead wire (2C).

Model no.	A	B	C	D	E	F	G	H	J	K	L
FLB21	40	34	30	25	15	15	ø5	ø4.5	6	1.2	20
FLB31	52	42	40	30	18	18	ø6	ø5.5	7	1.6	25
FLB41/51	56	48	44	36	18	18	ø6	ø5.5	7	1.6	30

HNB/G

USB/G

FAB/G

FGB/G

FVB

FWB/G

FHB

FLB

AB

AG

AP/
AD

APK/
ADK

For
dry air

Explosion
proof

HVB/
HVL

SAB/
SVB

NP/NAP/
NVP

CHB/G

MXB/G

Other G.P.
systems

PD/FAD/
PJ

CVE/
CVSE

CPE/
CPD

Medical
analysis

Custom
order

Special purpose valve for oil

Direct acting 2 port solenoid valve

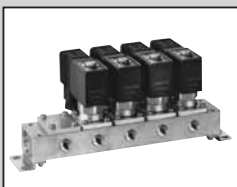

Direct acting 2 port solenoid valve for oil, manifold
(special purpose valve)

GFLB Series

- NC (normally closed) type
- Port size: Rc1/8, Rc1/4, Rc3/8



Refer to page 17 in the Ending for details.



JIS symbol

- NC (normally closed) / central lubrication type (port C pressurization)

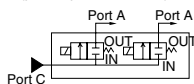

Common specifications

Item	Standard specifications	Optional specifications
Working fluid	Oil (50 mm ² /s) or less	
Working pressure differential range MPa	0 to 1.5	
Withstanding pressure (water) MPa	5.0 (3.0 for orifice ø7/ø10)	
Fluid temperature °C	AC: -10 to 60 DC: -10 to 40 (no freezing)	-10 to 90 (no freezing)
Ambient temperature °C	AC: -20 to 40 DC: -20 to 40	-20 to 60
Heat proof class	B	H or equivalent (AC only)
Atmosphere	Place free of corrosive gas and explosive gas	
Valve structure cm ³ /min.	Direct acting poppet structure	
Valve seat leakage	0 (oil)	
Mounting attitude	Free	
Protective structure	IP65 or equivalent (Note 1)	

Note 1: The T type terminal box type is IP61 or equivalent.

Individual specifications

Item Model no.	Port size		Orifice (mm)	Cv flow factor	Max. working pressure diff. MPa		Max. working pressure MPa	Rated voltage	Rated power (VA)				Power consumption (W)	
	Port A/NO (individual)	Port C (common)			AC	DC			Holding	Starting	AC 50/60 Hz	DC		
													50 Hz	60 Hz
NC (normally closed) type														
GFLB21-Z -2	Rc1/8	Rc1/4	1	0.036	1.5	1.0	1.5	100 VAC 50/60 Hz	6.5	5	9.5	8.5	3.6/2.4	4
			2	0.12	0.6	0.25								
GFLB31-3 -5 -6	Rc1/4	Rc3/8	3	0.23	0.8	0.5	1.5	110 VAC 60 Hz	15.5	10	24	20	6.5/4.0	6
			4	0.36	0.4	0.15								
			5	0.45	0.25	0.05								
GFLB41-5 -6 -7	Rc1/4	Rc3/8	4	0.42	0.8	0.45	0.3	200 VAC 50/60 Hz	22	15	45	40	8.5/6.5	8
			5	0.55	0.5	0.2								
			7	0.73	0.2	0.09								
GFLB51-5 -6 -7	Rc1/4	Rc3/8	4	0.42	1.1	1.3	1.5	220 VAC 60 Hz	32	22	65	55	12.5/10.5	11.5
			5	0.55	0.7	0.7								
			7	0.73	0.3	0.25			0.3					

*1: The voltage fluctuation must be within ±10% of the rated voltage.

*2: The leakage current must be less than the values shown below.

*3: 8.6 (W) for 12 VDC.

Leakage current	Voltage	100 VAC	200 VAC	24 VDC	12 VDC
	Model no.				
	GFLB2	3 mA or less	1.5 mA or less	1 mA or less	2 mA or less
	GFLB3/4/5	6 mA or less	3 mA or less	1 mA or less	2 mA or less

How to order

● Manifold

G F L B 2 1 - Z - 3 - B 2C - 1

● Manifold with masking plate

G F L B 5 1 - 6 - X - B 2G - 2 - 5 2

No. of port
(2 port valve)

Working fluid
(oil)

A Size variation

B Circuit structure

C Orifice

D Station no.

*1
*2

E Body/sealant combination

F Coil option

*3
*4
*5

G Voltage

*6

H No. of solenoid

*7 valves

I No. of masking plates

Model no.			
GFLB21	GFLB31	GFLB41	GFLB51

Symbol	Descriptions				
A Size variation					
2	22 mm	●			
3	28 mm		●		
4	34 mm			●	
5	40 mm				●

B Circuit structure					
1	NC (normally closed) / central lubrication type	●	●	●	●

C Orifice					
Z	ø1		●		
2	ø2		●		
3	ø3			●	
5	ø4				●
6	ø5				●
7	ø7				●

D Station no.					
2	2 stations				
to	to	●	●	●	●
10	10 stations				
O	Actuator only	●	●	●	●
X	With masking plate	●	●	●	●

E Body/sealant combination			
	Body	Sealant	
B	Brass	FKM	● ● ● ●

F Coil option					
2C	Std.	Grommet lead wire	●	●	●
2CS		Grommet lead wire with surge suppressor	●	●	●
2G		DIN terminal box (Pg11)	●	●	●
2HS		DIN terminal box with light and surge suppressor (Pg11)	●	●	●
2CG	Option	Conduit (CTC19)	●	●	●
2CH		Conduit (G1/2)	●	●	●
3T		T type terminal box (G1/2)	●	●	●
3RS		T type terminal box with light and surge suppressor (G1/2)	●	●	●
4A		Grommet lead wire (heat proof class H)	●	●	●

G Voltage					
1	100 VAC 50/60 Hz, 110 VAC 60 Hz	●	●	●	●
2	200 VAC 50/60 Hz, 220 VAC 60 Hz	●	●	●	●
3	24 VDC	●	●	●	●
4	12 VDC	●	●	●	●

For voltages other than above, directly write in the voltage.

H No. of solenoid valves					
Blank	No masking plate	●	●	●	●
1	One solenoid valve				
to	to	●	●	●	●
9	Nine solenoid valves				

I No. of masking plates					
Blank	No masking plate	●	●	●	●
1	One masking plate				
to	to	●	●	●	●
9	Nine masking plates				

Select from the combinations indicated with ● above.

<Example of model number>

GFLB21-Z-3-B2C-1
Model no.: GFLB

- A** Size variation: 22 mm
- B** Circuit structure: NC (normally closed) / central lubrication type
- C** Orifice: ø1
- D** Station no: 3 stations
- E** Body/sealant combination:
Body - brass, sealant - FKM
- F** Coil option: Grommet lead wire
- G** Voltage: 100 VAC 50/60Hz, 110 VAC 60Hz
- H** **I**: No masking plate

⚠ Note on model no. selection

- *1: For station no., select the number of stations from 2 to 10.
- *2: For the type with masking plate, designate **X**, then designate the numbers of solenoid valves and masking plates.
- *3: Grommet lead wire (heat proof class H) (**4A**) is available only for AC.
- *4: For GFLB21 **2G/2HS**, the compact terminal box (Pg9) is used.
- *5: For **2CS**, the surge suppressor is built into the coil, and for **2HS/3RS**, it is built into the terminal box.
- *6: Some voltages are not available. Contact CKD for details.
- *7: Solenoid valves are arranged from the right side facing the sub-plate (individual) port A.
- *8: Orders for only the masking plate and sub-plate are also available. Contact CKD for details.

HNB/G

USB/G

FAB/G

FGB/G

FVB

FWB/G

FHB

FLB

AB

AG

AP/AD

APK/ADK

For dry air

Explosion proof

HVB/HVL

SAB/SVB

NP/NAP/NVP

CHB/G

MXB/G

Other G.P. systems

PD/FAD/PJ

CVE/ CVSE

CPE/ CPD

Medical analysis

Custom order

Special purpose valve for oil

Direct-acting 2 port solenoid valve

Internal structure and parts list

● GFLB Actuator

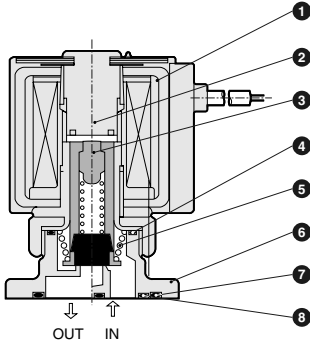

● GFLB Manifold

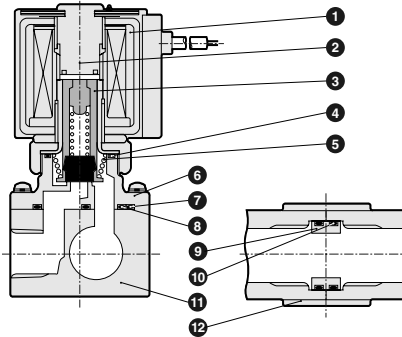

No.	Parts name	Material	No.	Parts name	Material
1	Coil assembly	—	7	O ring	FKM Fluoro rubber
2	Core assembly	SUS, Cu	8	O ring	FKM Fluoro rubber
3	Plunger assembly	SUS, C3604, FKM	9	Connector	C3604 Brass
4	O ring	FKM	10	O ring	FKM Fluoro rubber
5	Spring	SUS	11	Sub-plate	C3604 Brass
6	Body	C3771	12	Connecting plate	SPC Steel

Dimensions: Manifold

 (Page 116)

- Grommet lead wire type
GFLB*1-*-*B2C

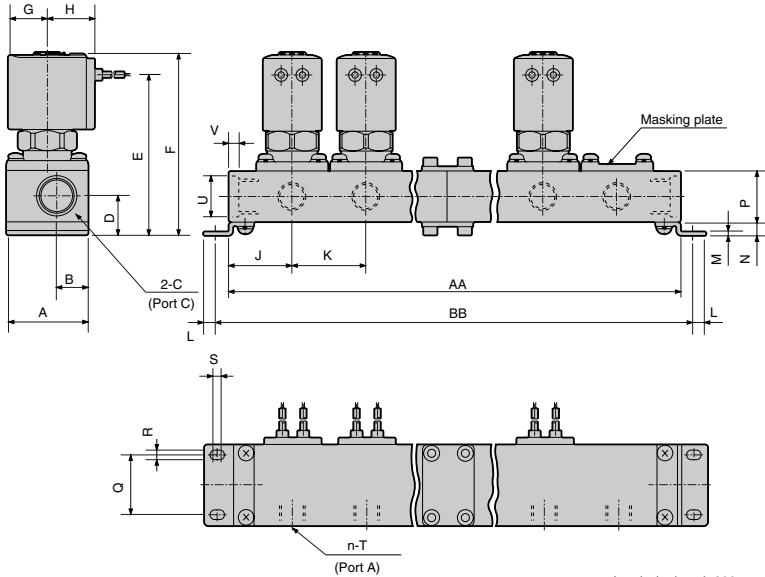

Lead wire length 300 mm

Model no.	Station Symbol	2	3	4	5	6	7	8	9	10
GFLB2	AA	81	109	162	165	218	246	274	327	330
	BB	93	121	174	177	230	258	286	339	342
GFLB3	AA	97	133	194	205	266	302	338	399	410
	BB	109	145	206	217	278	314	350	411	422
GFLB4	AA	106	145	212	223	290	329	368	435	446
	BB	119	158	225	236	303	342	381	448	459
GFLB5	AA	118	163	236	253	326	371	416	489	506
	BB	131	176	249	266	339	384	429	502	519

Manifold structure 2 stations x 1 | 3 stations x 1 | 2 stations x 2 | 5 stations x 1 | 3 stations x 2 | 5 stations x 2 | 5 stations x 3 | 5 stations x 3 | 5 stations x 2
 Note: A manifold is configured by combining 2-, 3- and 5-station modules.

Model no.	A	B	C	D	E	F	G	H	J	K	L	M	N	P	Q	R	S	T	U	V
GFLB2	32	13.5	Rc1/4	17.5	66.5	77	15.5	19.5	26	28	6	1.6	6.5	21	22	4.5	2.5	Rc1/8	ø17.3	4
GFLB3	38	14.5	Rc3/8	18.5	75.5	86.5	18.5	22.5	30	36	6	2	6.5	24	28	4.5	2.5	Rc1/4	ø19	4.6
GFLB4	42	16.5	Rc3/8	19.5	84	98	22.5	26	33	39	6.5	2	7.5	24	30	5.5	2.5	Rc1/4	ø19	4.6
GFLB5	42	16.5	Rc3/8	19.5	90	105	26	29.5	36	45	6.5	2	7.5	24	30	5.5	2.5	Rc1/4	ø19	4.6

HNB/G
 USB/G
 FAB/G
 FGB/G
 FVB
 FWB/G
 FHB
FLB
 AB
 AG
 AP/
 AD
 APK/
 ADK
 For
 dry air
 Explosion
 proof
 HVB/
 HVL
 SAB/
 SVB
 NP/NAP/
 NVP
 CHB/G
 MXB/G
 Other G.P.
 systems
 PD/FAD/
 PJ
 CVE/
 CVSE
 CPE/
 CPD
 Medical
 analysis
 Custom
 order

Special purpose valve for oil
 Direct-acting 2 port solenoid valve

Dimensions: Actuator

- Grommet lead wire type
GFLB*1-*O-B2C

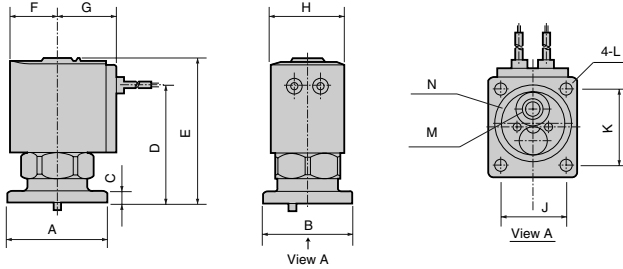

Model no.	A	B	C	D	E	F	G	H	J	K	L	Applicable O ring	
												M	N
GFLB2	32	27	4	39	49.5	15.5	19.5	22	19	24	ø3.5	AS568-009	AS568-018
GFLB3	38	34	4.5	45	56	18.5	22.5	28	25	29	ø4.5	AS568-011	AS568-022
GFLB4	42	38	4.5	52.5	66.5	22.5	26	34	28	32	ø4.5	AS568-012	AS568-025
GFLB5	42	44	5.5	58.5	73.5	26	29.5	40	34	32	ø4.5	AS568-012	AS568-025

Mounting dimensions of actuator

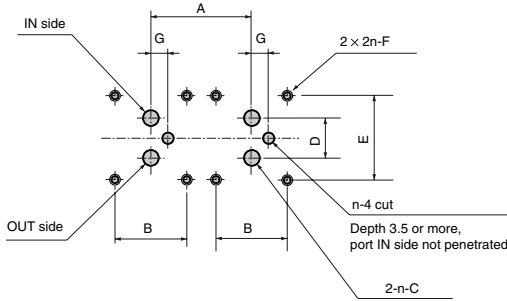

Machining drawing when using 2 actuators

Model no.	A	B	C	D	E	F	G
GFLB2	28 or more	19±0.1	3.5 cut or less	10.6±0.1	24±0.1	M3 effective thread depth 6 or more	6±0.2
GFLB3	35 or more	25±0.1	5.5 cut or less	13.8±0.1	29±0.1	M4 effective thread depth 6 or more	6±0.2
GFLB4	39 or more	28±0.1	7.5 cut or less	17±0.1	32±0.1	M4 effective thread depth 6 or more	7±0.2
GFLB5	45 or more	34±0.1	7.5 cut or less	17±0.1	32±0.1	M4 effective thread depth 6 or more	7±0.2

Optional dimensions

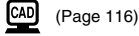

(Refer to the grommet lead wire type dimensions on the left page for common dimensions.)

- Grommet lead wire with surge suppressor
GFLB*1-*-*B^{2CS}

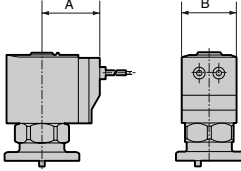

Model no.	A	B
GFLB2	26.5	22
GFLB3	29.5	28
GFLB4	34	34
GFLB5	37.5	40

- DIN terminal box (with light and surge suppressor)
GFLB*1-*-*B^{2G}
_{2HS}

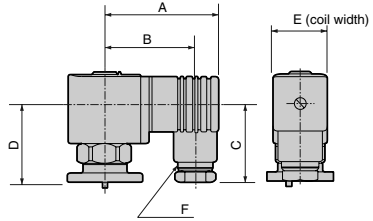

Model no.	A	B	C	D	E	F
GFLB2	53	44	38	32.5	22	Pg9
GFLB3	58.5	47	42	38.5	28	Pg11
GFLB4	62	50.5	42	46.5	34	Pg11
GFLB5	65.5	54	42	54	40	Pg11

- Conduit (CTC19, G1/2)
GFLB*1-*-*B^{2CG}
_{2CH}

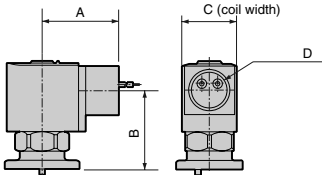

Model no.	A	B	C	D
GFLB3	39	40.5	28	CTC19, G1/2
GFLB4	43	48	34	CTC19, G1/2
GFLB5	46.5	55.5	40	CTC19, G1/2

- T type terminal box (with light and surge suppressor) (G1/2)
GFLB*1-*-*B^{3T}
_{3RS}

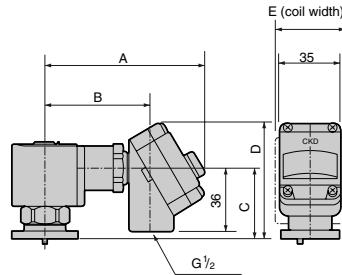

Model no.	A	B	C	D	E
GFLB3	92	60.5	40.5	66.5	28
GFLB4	96	64.5	48	74	34
GFLB5	99.5	68	55.5	81.5	40

HNB/G
USB/G
FAB/G
FGB/G
FVB
FWB/G
FHB
FLB
AB
AG
AP/
AD
APK/
ADK
For
dry air
Explosion
proof
HVB/
HVL
SAB/
SVB
NP/NAP/
NVP
CHB/G
MXB/G
Other G.P.
systems
PD/FAD/
PJ
CVE/
CVSE
CPE/
CPD
Medical
analysis
Custom
order

Special purpose valve for oil
Direct acting 2 port solenoid valve

Special Purpose Valve Series

Electronic Catalog file list

Special purpose direct acting 2, 3 port solenoid valve (special purpose valve)

Compressed air

Electronic Catalog file list is applied to "CAD DATA 2006".

Model no.	DXF		MICRO CADAM
	Folder name	Filename	Filename (GROUP: CAD, USER: STDLIB)
● Discrete 2 port solenoid valve: Pages 28, 30			
FAB11	FAB	fab11	CKD-FAB11
FAB21		fab21	CKD-FAB21
FAB31		fab31	CKD-FAB31
FAB41		fab41	CKD-FAB41
FAB51		fab51	CKD-FAB51
FAB32		fab32	CKD-FAB32
FAB42		fab42	CKD-FAB42
FAB52		fab52	CKD-FAB52
● 2 port solenoid valve, manifold: Page 35			
GFAB11(5)	FAB	gfab11_5_	CKD-GFAB11(5)
GFAB21(5)		gfab21_5_	CKD-GFAB21(5)
GFAB31(5)		gfab31_5_	CKD-GFAB31(5)
GFAB41(5)		gfab41_5_	CKD-GFAB41(5)
GFAB51(5)		gfab51_5_	CKD-GFAB51(5)
● Option			
FAB1 option depth 18 mm	FAB	fab1_opt	CKD-FAB1-OPT
FAB2 option depth 22 mm		fab2_opt	CKD-FAB2-OPT
FAB3 option depth 28 mm		fab3_opt	CKD-FAB3-OPT
FAB4 option depth 34 mm		fab4_opt	CKD-FAB4-OPT
FAB5 option depth 40 mm		fab5_opt	CKD-FAB5-OPT
● Discrete 3 port solenoid valve: Page 40			
FAG11	FAG	fag11	CKD-FAG11
FAG21		fag21	CKD-FAG21
FAG31(3)		fag31_3_	CKD-FAG31(3)
FAG41(3)		fag41_3_	CKD-FAG41(3)
FAG51		fag51	CKD-FAG51
● 3 port solenoid valve, manifold: Page 45			
GFAG11	FAG	gfag11	CKD-GFAG11
GFAG21		gfag21	CKD-GFAG21
GFAG31		gfag31	CKD-GFAG31
GFAG41		gfag41	CKD-GFAG41
GFAG51		gfag51	CKD-GFAG51
● Option			
FAG1 option depth 18 mm	FAG	fag1_opt	CKD-FAG1-OPT
FAG2 option depth 22 mm		fag2_opt	CKD-FAG2-OPT
FAG3 option depth 28 mm		fag3_opt	CKD-FAG3-OPT
FAG4 option depth 34 mm		fag4_opt	CKD-FAG4-OPT
FAG5 option depth 40 mm		fag5_opt	CKD-FAG5-OPT

Special Purpose Valve Series

Electronic Catalog file list

Dry air

Electronic Catalog file list is applied to "CAD DATA 2006".

Model no.	DXF		MICRO CADAM	
	Folder name	Filename	Filename (GROUP: CAD, USER: STDLIB)	
● Discrete 2 port solenoid valve: Page 50				
FGB21	FGB	fgb21	CKD-FGB21	HNB/G
FGB31		fgb31	CKD-FGB31	USB/G
FGB41		fgb41	CKD-FGB41	FAB/G
FGB51		fgb51	CKD-FGB51	FGB/G
● 2 port solenoid valve, manifold: Page 55				
GFGB21(5)	FGB	gfgb21_5_	CKD-GFGB21(5)	FVB
GFGB31(5)		gfgb31_5_	CKD-GFGB31(5)	FWB/G
GFGB41(5)		gfgb41_5_	CKD-GFGB41(5)	FHB
GFGB51(5)		gfgb51_5_	CKD-GFGB51(5)	FLB
● Option				
FGB2 option depth 22 mm	FGB	fgb2_opt	CKD-FGB2-OPT	AB
FGB3 option depth 28 mm		fgb3_opt	CKD-FGB3-OPT	AG
FGB4 option depth 34 mm		fgb4_opt	CKD-FGB4-OPT	AP/AD
FGB5 option depth 40 mm		fgb5_opt	CKD-FGB5-OPT	APK/ADK
● Discrete 3 port solenoid valve: Page 60				
FGG21	FGG	fgg21	CKD-FGG21	For dry air
FGG31(3)		fgg31_3_	CKD-FGG31(3)	Explosion proof
FGG41(3)		fgg41_3_	CKD-FGG41(3)	HVB/HVL
FGG51		fgg51	CKD-FGG51	SAB/SVB
● 3 port solenoid valve, manifold: Page 65				
GFGG21	FGG	gfgg21	CKD-GFGG21	NP/NAP/NVP
GFGG31		gfgg31	CKD-GFGG31	CHB/G
GFGG41		gfgg41	CKD-GFGG41	MXB/G
GFGG51		gfgg51	CKD-GFGG51	Other G.P. systems
● Option				
FGG2 option depth 22 mm	FGG	fgg2_opt	CKD-FGG2-OPT	PDF/FAD/PJ
FGG3 option depth 28 mm		fgg3_opt	CKD-FGG3-OPT	CVE/CVSE
FGG4 option depth 34 mm		fgg4_opt	CKD-FGG4-OPT	CPE/CPD
FGG5 option depth 40 mm		fgg5_opt	CKD-FGG5-OPT	Medical analysis

Medium vacuum

Model no.	DXF		MICRO CADAM	
	Folder name	Filename	Filename (GROUP: CAD, USER: STDLIB)	
● Discrete 2 port solenoid valve: Page 70				
FVB21	FVB	fvb21	CKD-FVB21	Custom order
FVB31		fvb31	CKD-FVB31	Special purpose valve Direct acting 2-, 3 port solenoid valve
FVB41		fvb41	CKD-FVB41	
FVB51		fvb51	CKD-FVB51	
● 2 port solenoid valve, manifold: Page 75				
GFVB25	FVB	gfvb25	CKD-GFVB25	
GFVB35		gfvb35	CKD-GFVB35	
GFVB45		gfvb45	CKD-GFVB45	
GFVB55		gfvb55	CKD-GFVB55	
● Option				
FVB2 option depth 22 mm	FVB	fvb2_opt	CKD-FVB2-OPT	
FVB3 option depth 28 mm		fvb3_opt	CKD-FVB3-OPT	
FVB4 option depth 34 mm		fvb4_opt	CKD-FVB4-OPT	
FVB5 option depth 40 mm		fvb5_opt	CKD-FVB5-OPT	

Special Purpose Valve series

Electronic Catalog file list

Water

Electronic Catalog file list is applied to "CAD DATA 2006".

Model no.	DXF		MICRO CADAM
	Folder name	Filename	Filename (GROUP: CAD, USER: STDLIB)
● Discrete 2 port solenoid valve: Pages 80, 82			
FWB21	FWB	fw_l_b21	CKD-FW(L)B21
FWB31		fw_l_b31	CKD-FW(L)B31
FWB41		fw_l_b41	CKD-FW(L)B41
FWB41-*-8		fw_l_b41___8	CKD-FW(L)B41-*-8
FWB51		fw_l_b51	CKD-FW(L)B51
FWB51-*-8		fw_l_b51___8	CKD-FW(L)B51-*-8
FWB32		fwb32	CKD-FWB32
FWB42		fwb42	CKD-FWB42
FWB52	fwb52	CKD-FWB52	
● 2 port solenoid valve, manifold: Page 87			
GFWB21	FWB	gfw_l_b21	CKD-GFW(L)B21
GFWB31		gfw_l_b31	CKD-GFW(L)B31
GFWB41		gfw_l_b41	CKD-GFW(L)B41
GFWB51		gfw_l_b51	CKD-GFW(L)B51
● Option			
FWB2 option depth 22 mm	FWB	fw_l_b2_opt	CKD-FW(L)B2-OPT
FWB3 option depth 28 mm		fw_l_b3_opt	CKD-FW(L)B3-OPT
FWB4 option depth 34 mm		fw_l_b4_opt	CKD-FW(L)B4-OPT
FWB5 option depth 40 mm		fw_l_b5_opt	CKD-FW(L)B5-OPT
● Discrete 3 port solenoid valve: Page 92			
FWG21	FWG	fwg21	CKD-FWG21
FWG31		fwg31	CKD-FWG31
FWG41		fwg41	CKD-FWG41
FWG51		fwg51	CKD-FWG51
● 3 port solenoid valve, manifold: Pages 97 to 98			
GFWG21	FWG	gfwg21	CKD-GFWG21
GFWG31		gfwg31	CKD-GFWG31
GFWG41		gfwg41	CKD-GFWG41
GFWG51		gfwg51	CKD-GFWG51
● Option			
FWG2 option depth 22 mm	FWG	fwg2_opt	CKD-FWG2-OPT
FWG3 option depth 28 mm		fwg3_opt	CKD-FWG3-OPT
FWG4 option depth 34 mm		fwg4_opt	CKD-FWG4-OPT
FWG5 option depth 40 mm		fwg5_opt	CKD-FWG5-OPT

Hot water

Model no.	DXF		MICRO CADAM
	Folder name	Filename	Filename (GROUP: CAD, USER: STDLIB)
● Discrete 2 port solenoid valve: Page 103			
FHB21	FHB	fhb21	CKD-FHB21
FHB31		fhb31	CKD-FHB31
FHB41		fhb41	CKD-FHB41
FHB41-*-8		fhb41___8	CKD-FHB41-*-8
FHB51		fhb51	CKD-FHB51
FHB41-*-8		fhb41___8	CKD-FHB41-*-8

For oil

Model no.	DXF		MICRO CADAM	
	Folder name	Filename	Filename (GROUP: CAD, USER: STDLIB)	
● Discrete 2 port solenoid valve: Page 106				
FLB21	FLB	fw_l_b21	CKD-FW(L)B21	
FLB31		fw_l_b31	CKD-FW(L)B31	
FLB41		fw_l_b41	CKD-FW(L)B41	
FLB41-*-8		fw_l_b41___8	CKD-FW(L)B41-*-8	
FLB51		fw_l_b51	CKD-FW(L)B51	
FLB51-*-8		fw_l_b51___8	CKD-FW(L)B51-*-8	
● 2 port solenoid valve, manifold: Page 111				
GFLB21		FLB	gfw_l_b21	CKD-GFW(L)B21
GFLB31	gfw_l_b31		CKD-GFW(L)B31	
GFLB41	gfw_l_b41		CKD-GFW(L)B41	
GFLB51	gfw_l_b51		CKD-GFW(L)B51	
● Option				
FLB2 option depth 22 mm	FLB	fw_l_b2_opt	CKD-FW(L)B2-OPT	
FLB3 option depth 28 mm		fw_l_b3_opt	CKD-FW(L)B3-OPT	
FLB4 option depth 34 mm		fw_l_b4_opt	CKD-FW(L)B4-OPT	
FLB5 option depth 40 mm		fw_l_b5_opt	CKD-FW(L)B5-OPT	

FA^B_G / FG^B_G / FVB FW^B_G / FHB / FLB

(Special purpose valve)

Special purpose direct acting 2, 3 port solenoid valve

■ For compressed air, dry air, medium vacuum, water, hot water, oil

Overview

This is a direct acting poppet type solenoid valve. Six series for compressed air, dry air, medium vacuum, water, hot water and oil applications are available to suit the control fluid. Dedicated fluid design is suited for all types of fluids. Select the optimum series based on the fluid.

Features

Dedicated fluid design

Special purpose design to fit the required fluid.

Double life (CKD comparison)

Long life even for dry air and inert gas applications.

26% reduced footprint

(CKD comparison)

56% reduced weight

(CKD comparison for compressed air)

Surge suppressor integrated coil

(with surge suppressor)

Low wattage design

Flame resistant UL94V-0

conformed coil

Easy disassembly and assembly

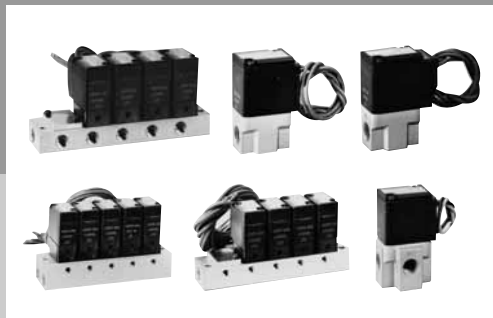

CONTENTS

Series variation 22

▲ Safety precautions 24

For compressed air

2 port solenoid valve

● FAB (discrete valve) 26

● GFAB (manifold) 32

3 port solenoid valve

● FAG (discrete valve) 38

● GFAG (manifold) 42

For dry air

2 port solenoid valve

● FGB (discrete valve) 48

● GFGB (manifold) 52

3 port solenoid valve

● FGG (discrete valve) 58

● GFGG (manifold) 62

For medium vacuum

2 port solenoid valve

● FVB (discrete valve) 68

● GFVB (manifold) 72

For water

2 port solenoid valve

● FWB (discrete valve) 78

● GFWB (manifold) 84

3 port solenoid valve

● FWG (discrete valve) 90

● GFWG (manifold) 94

For hot water

2 port solenoid valve

● FHB (discrete valve) 100

For oil

2 port solenoid valve

● FLB (discrete valve) 104

● GFLB (manifold) 108

Electronic Catalog file list 114

▲ Always read the precautions in the Introduction and page 24 before starting use.

HNB/G

USB/G

FAB/G

FGB/G

FVB

FWB/G

FHB

FLB

AB

AG

AP/
AD

APK/
ADK

For
dry air

Explosion
proof

HVB/
HVL

SAB/
SVB

NP/NAP/
NVP

CHB/G

MXB/G

Other G.P.
systems

PD/FAD/
PJ

CVB/
CVSE

CPE/
CPD

Medical
analysis

Custom
order

Special purpose valve
Direct acting 2, 3 port solenoid valve

Series variation

Special purpose direct acting 2, 3 port solenoid valve
(special purpose valve)

Working fluid	No. of port	Model	Structure	Actuation
Compressed air	2 port	FAB	Discrete	NC (normally closed) type
		GFAB	Manifold	NO (normally open) type
	3 port	FAG	Discrete	Common supply type
		GFAG	Manifold	Individual supply type
		FAG	Discrete	Universal type
				NC pressurization type
GFAG	Manifold	Common air supply/ exhaust type		
Dry air	2 port	FGB	Discrete	NC (normally closed) type
		GFGB	Manifold	Common supply type
	3 port	FGG	Discrete	Individual supply type
		GFGG	Manifold	Universal type
		FGG	Discrete	NC pressurization type
				Common air supply/ exhaust type
GFGG	Manifold			
Medium vacuum	2 port	FVB	Discrete	NC (normally closed) type
		GFVB	Manifold	Individual supply type
Water	2 port	FWB	Discrete	NC (normally closed) type
		GFWB	Manifold	NO (normally open) type
	3 port	FWG	Discrete	Common water supply type
		GFWG	Manifold	Universal type
		FWG	Discrete	Common water supply/ individual drain type
GFWG	Manifold			
Hot water	2 port	FHB	Discrete	NC (normally closed) type
Oil	2 port	FLB	Discrete	NC (normally closed) type
		GFLB	Manifold	Central lubrication type

	Port size					Page
	M5	Rc1/8	Rc1/4	Rc3/8	Rc1/2	
	●	●	●	●	●	26
		●	●	●		
		●		●		32
	●	●	●			
	●	●	●	●		38
		●	●	●		
	●	●	●			42
		●	●	●	●	
		●	●	●	●	48
		●		●		
		●	●			52
		●	●	●		
		●	●	●		58
		●	●	●		
		●	●			62
		●	●	●		
		●	●	●		68
		●	●			
		●	●			72
		●	●	●	●	
		●	●	●		78
		●	●	●		
		●	●	●		84
		●	●	●		
		●	●	●		90
		●	●	●		
		●	●	●		94
		●	●	●		
		●	●	●	●	100
		●	●	●	●	
		●	●	●		104
		●	●	●		
		●	●	●		108
		●	●	●		

HNB/G

USB/G

FAB/G

FGB/G

FVB

FWB/G

FHB

FLB

AB

AG

AP/
ADAPK/
ADKFor
dry airExplosion
proofHVB/
HVLSAB/
SVBNP/NAP/
NVP

CHB/G

MXB/G

Other G.P.
systemsPD/FAD/
PJCVE/
CVSECPE/
CPDMedical
analysisCustom
order

Special purpose valve

Direct acting 2, 3 port solenoid valve

* Note: Port size of manifold indicates pressure port.



Safety precautions

Always read this section before starting use.

Special purpose direct acting 2, 3 port solenoid valve (special purpose valve)

Design & Selection

WARNING

1 Working fluid

- (1) Active gases cannot be used with the compressed air and dry air types, so consult with CKD when these applications are required.
- (2) Dedicated solenoid valve for each fluid. Select the solenoid valve based on the fluid. When using with other fluids, for example, in an air flow in water, specifications may differ, so consult with CKD.

2 Protective structure

The protective structure of the special purpose valve has passed IEC standard compliance tests, but performance greatly differs based on weather resistance and time, so these values are not guaranteed.

Provide means to ensure that water, dust, etc., do not come in direct contact.

CAUTION

1 Continuous energizing

Consult with CKD when the 3 port valve for water (FWG) is to be continuously energized with the NO port pressurized.

2 Fluid viscosity

The fluid viscosity must be 50 mm²/s or less.

Malfunctions could occur if the viscosity is higher than 50 mm²/s.

Installation, Piping & Wiring

CAUTION

1 Piping

Always hold the socket with a spanner, etc., when tightening the piping to the FWG Series NO port.

2 Wiring

Refer to the connection methods in Introduction 53 when wiring to the small terminal box, DIN terminal box or T type terminal box.

Maintenance

CAUTION

1 For compressed air, dry air, medium vacuum

- (1) When disassembling or assembling the FAB/G or FGB/G Series, tighten the coil assembly set screws with the following tightening torques.

Model no.	Coil assembly set screw
FAB/G1	0.3 to 0.7 N·m
FAB/G2/FGB/G2	0.7 to 1.1 N·m
FAB/G3/FGB/G3	1.1 to 1.8 N·m
FAB/G4/FGB/G4	1.1 to 1.8 N·m
FAB/G5/FGB/G5	2.0 to 3.0 N·m

- (2) When disassembling or assembling the FAB32/42/52 or FVB Series, tightening the core assembly and body with the following tightening torques.

Model no.	Core assembly set screw
FVB2	12 to 18 N·m
FAB32/FVB3	16 to 24 N·m
FAB42/FVB4	21 to 31 N·m
FAB52/FVB5	21 to 31 N·m

2 For water, hot water, oil

When disassembling or assembling the FWB/G, FHB or FLB Series and tightening the core assembly and body, and core assembly and socket, first temporarily tighten until the core assembly contacts the O ring to prevent entanglement of the spring (outer spring). Then tighten with the following torques.

Model no.	Core assembly tightening torque	Socket tightening torque
FWB2/FHB2/FLB2	12 to 18 N·m	_____
FWG2		3 to 5 N·m
FWB3/FHB3/FLB3	16 to 24 N·m	_____
FWG3		6 to 10 N·m
FWB4/FHB4/FLB4	21 to 31 N·m	_____
FWG4		10 to 14 N·m
FWB5/FHB5/FLB5	21 to 31 N·m	_____
FWG5		10 to 14 N·m

How to operate manual override (optional) (FAB/FAG/FGB/FGG/GFAB/GFAG/GFGB/GFGG Series)

1 Manual locking type (available for FAB/FAG/FGB/FGG Series)

Opening: Insert a flat-tip screwdriver into the slit on the manual shaft, and turn it approx. 90° to the right. The plunger will rise up and the valve will open. (For the 3 port valve, the NC side valve seat will open and the NO side valve seat will close.) This opened state will be maintained even if the screwdriver is removed.

Closing: Turn the manual shaft to the left from the open position to the close position. The plunger will lower and the valve will close. (For the 3 port valve, the NC side valve seat will close and the NO side valve seat will open.)

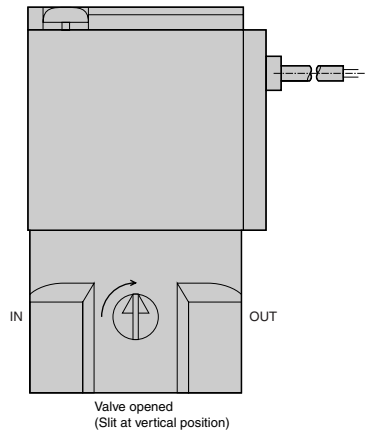
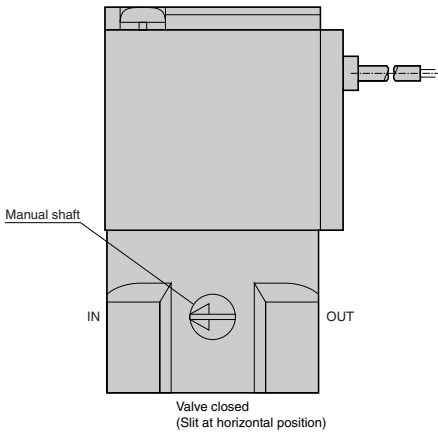

2 Manual non-locking type

Opening: When the concave section at the center of the manual shaft is pressed in with the fine tip of a Phillips screwdriver, the plunger assembly will rise up and the valve will open. (For the 3 port valve, the NC side valve seat will open and the NO side valve seat will close.)

Closing: When the screwdriver is removed from the manual shaft, the manual shaft will return to the front by the force of the inner spring, and the plunger assembly will lower and the valve will close. (For the 3 port valve, the NC side valve seat will close and the NO side valve seat will open.)

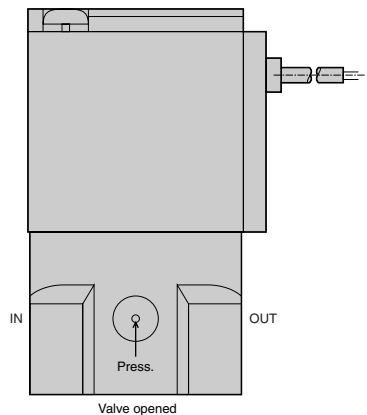
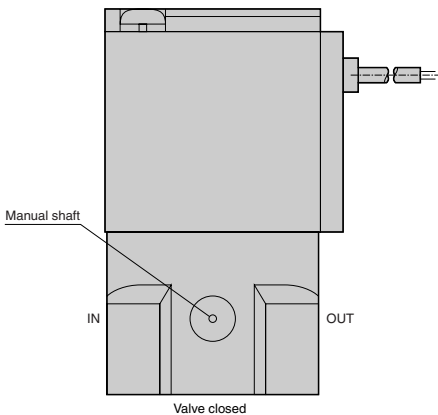

HNB/G

USB/G

FAB/G

FGB/G

FVB

FWB/G

FHB

FLB

AB

AG

AP/
AD

APK/
ADK

For
dry air

Explosion
proof

HVB/
HVL

SAB/
SVB

NP/NAP/
NVP

CHB/G

MXB/G

Other G.P.
systems

PD/FAD/
PJ

CVE/
CVSE

CPE/
CPD

Medical
analysis

Custom
order

Special purpose valve

Direct acting 2, 3 port solenoid valve