



High energy absorption cylinder HCM Series

● : Standard, ◎ : Option, ■ : Not available

Variation	Model no. JIS symbol	Bore size (mm)	Standard stroke length (mm)																	Min. stroke length (mm) Note 1	Max. stroke length (mm)	Custom stroke length (per mm)	Mounting style				Cushion				Option		Accessory		Switch	Page
			200	250	300	350	400	450	500	550	600	650	700	750	800	850	900	950	1000				Basic type	Axial foot type	Rod end flange type	Head end flange type	Both sides cushioned	Rod end cushion	Head end cushion	No cushion	Switch rail attached at shipment	Piston rod material (stainless steel)	Rod eye	Rod clevis		
			00	LB	FA	FB	B	R	H	N	Q	M	I	Y																						
Double acting single rod type	HCM	 $\phi 20, \phi 25, \phi 32$	●	●	●	●	●	●	●	●	●	●	●	●	●	●	●	●	1	700	1	●	●	●	●	●	●	●	●	◎	◎	◎	◎	◎	1960	
			$\phi 40, \phi 50, \phi 63$	●	●	●	●	●	●	●	●	●	●	●	●	●	●	●	●	●	1	1000	1	●	●	●	●	●	●	●	●	◎	◎	◎	◎	◎

High speed cylinder HCA Series

● : Standard, ◎ : Option, ■ : Not available

Variation	Model no. JIS symbol	Bore size (mm)	Standard stroke length (mm)														Stroke length (mm)				Min. stroke length (mm) Note 1	Max. stroke length (mm)	Custom stroke length (mm)	Mounting style				Cushion				Switch	Page	
			400	450	500	550	600	650	700	750	800	850	900	950	1000	Basic type	Axial foot type	Rod end flange type	Head end flange type	Both sides cushioned				Rod end cushion	Head end cushion	No cushion								
			00	LB	FA	FB	B	R	H	N																								
Double acting single rod type	HCA	 $\phi 20, \phi 25, \phi 32$	●	●	●	●	●	●	●	●	●	●	●	●	●	●	●	●	1	700	1	●	●	●	●	●	●	●	●	◎	◎	◎	◎	1978
			$\phi 40, \phi 50, \phi 63$ $\phi 80, \phi 100$	●	●	●	●	●	●	●	●	●	●	●	●	●	●	●	●	1	1000	1	●	●	●	●	●	●	●	●	◎	◎	◎	◎

Note: Bore size 25, 63, 80, and 100 are custom orders.

Note 1: The stroke is available from 1mm. However, this product's cushion area is longer than a typical cylinder so that a high energy can be absorbed. Thus, the cushion is applied in the following strokes, and an effect for use at a high-speed will not be achieved.

Model no.	Stroke which effect of high-speed cannot be anticipated	Recommended stroke length
HCM	150mm mm stroke or less	300mm stroke and over
HCA	200mm mm stroke or less	400mm stroke and over

SCP*2
CMK2
CMA2
SCM
SCG
SCA2
SCS
CKV2
CA/OV2
SSD
CAT
MDC2
MVC
SMD2
MSD*
FC*
STK
ULK*
JSK/M2
JSG
JSC3
USSD
USC
JSB3
LMB
STG
STS/L
LCS
LCG
LCM
LCT
LCY
STR2
UCA2
HCM
HCA
SRL2
SRG
SRM
SRT
MRL2
MRG2
SM-25
CAC3
UCAC
RCC2
MFC
SHC
GLC
Ending

SCP*2
CMK2
CMA2
SCM
SCG
SCA2
SCS
CKV2
CA/OV2
SSD
CAT
MDC2
MVC
SMD2
MSD*
FC*
STK
ULK*
JSK/M2
JSG
JSC3
USSD
USC
JSB3
LMB
STG
STS/L
LCS
LCG
LCM
LCT
LCY
STR2
UCA2
HCM
HCA
SRL2
SRG
SRM
SRT
MRL2
MRG2
SM-25
CAC3
UCAC
RCC2
MFC
SHC
GLC
Ending

Variation and option selection table

- ◎ : Option
- : Available (custom order)
- △ : Available depending on conditions (consult with CKD)
- X : Not available

Code		Code	Variation		Port thread		Option		
			Double acting basic type	With cylinder switch	NPT	G	Switch rail attached at shipment	Piston rod material stainless steel	Customized piston rod end form
		Symbol	No	No	N	G	Q	M	N*
Variation	Double acting basic type	Blank	◎		○	○	X	◎	○
Variation	With cylinder switch	Blank			○	○	◎	◎	○
Port thread	NPT	N				X	○	○	○
Port thread	G	G					○	○	○
Option	Switch rail attached at shipment	Q						◎	○
Option	Piston rod material stainless steel	M							○
Option	Customized piston rod end form	N*							
Accessory	Cylinder switch	Listed on Ending	◎	◎	○	○	◎	◎	○
Accessory	Rod eye	I	◎	◎	○	○	◎	◎	△
Accessory	Rod clevis	Y	◎	◎	○	○	◎	◎	△

Note: φ20, 25 is as a piston rod material SUS as standard. Option for φ 32 to 63.

<Example of model number>

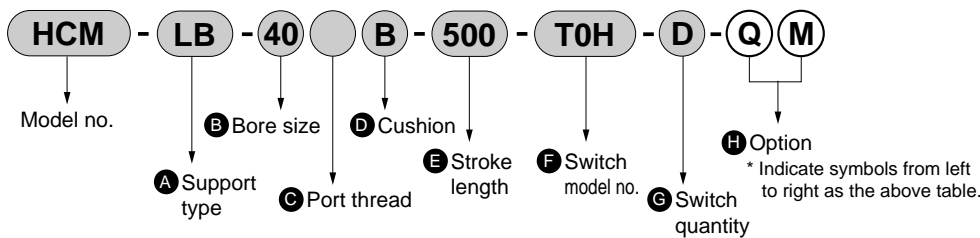

Model no.: high energy absorption cylinder

- Variation: Double acting, basic type
- A** Mounting style : axial foot type
- B** Bore size : φ 40mm
- C** Port thread type : Rc thread
- D** Cushion : both sides cushioned
- E** Stroke length : 500mm
- F** Switch model no. : reed T0H switch, lead wire 1m
- G** With switch quantity : 2
- H** Option : Switch rail attached at shipment, piston rod material (stainless steel)

Cushion operational principle

1. When the piston moves and pushes the cushion ring into the cushion packing, a sealed air space forms in the shaded section. When the piston moves further, the air in the shaded section is compressed and kinetic energy in the direction of movement is absorbed.

● Before rush into cushion

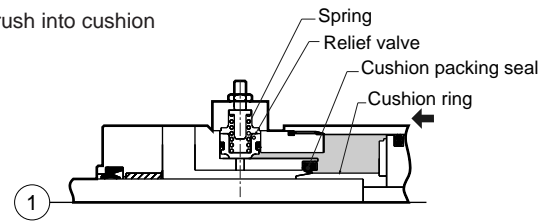

2. At the same time, the relief valve is opened by compressed air. Compressed air is instantaneously exhausted and the relief valve closes.

● Cushion operation I

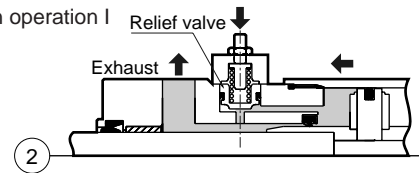

3. After the relief valve closes, remaining compressed air is exhausted from the slit orifice. The position moves and contacts the cover. The energy absorption stroke is completed at this time.

● Cushion operation II

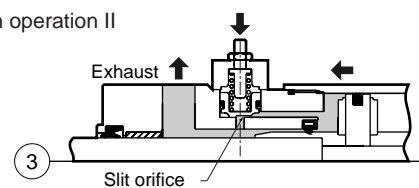

Applications

● Resin molding machine ejection robot

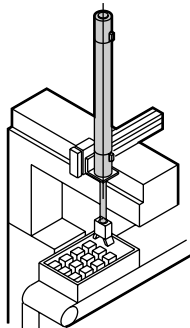

● Machine door open and close

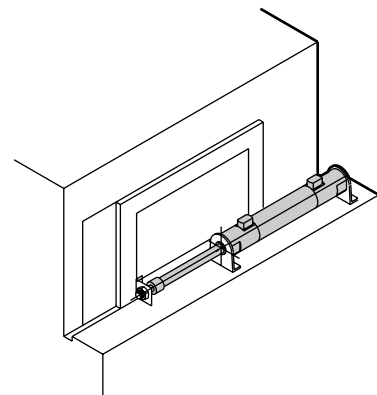

SCP*2
CMK2
CMA2
SCM
SCG
SCA2
SCS
CKV2
CA/OV2
SSD
CAT
MDC2
MVC
SMD2
MSD*
FC*
STK
ULK*
JSK/M2
JSG
JSC3
USSD
USC
JSB3
LMB
STG
STS/L
LCS
LCG
LCM
LCT
LCY
STR2
UCA2
HCM
HCA
SRL2
SRG
SRM
SRT
MRL2
MRG2
SM-25
CAC3
UCAC
RCC2
MFC
SHC
GLC
Ending

High energy absorption cylinder
High-speed type



Pneumatic components

Safety precautions

Always read this section before starting use.

Refer to Intro 71 for general details on the cylinder, and to Intro 78 for details on the cylinder switch.

High energy absorption cylinder HCM Series

Design & Selection

CAUTION

- The cylinder port is designed so a speed of 2000 mm/s or more is attainable. A speed control valve must be installed to ensure use within the specification range.
- The maximum speed for the working piston is 2000 mm/s, which is not the average speed.
- Avoid applying a lateral load to the cylinder piston rod. The required speed may not be attained, bearings may wear abnormally, and performance may drop.

■ Cushion

The air cushion absorbs kinetic energy that the piston generates using air compressibility and prevents the piston and cover from colliding at the stroke end. The cushion is not used to decelerate the piston near the stroke end.

- The cylinder system selection guide differs with working conditions (working pressure, load movement direction/method, and piping length) and is for reference only.

- If the cylinder is moved at high speed, the instantaneous airflow increases and causes drain, etc., to accumulate easily. Provide an air tank to prevent drain from entering the cylinder and to prevent pressure loss when filtering oil mist.

Installation & Adjustment

CAUTION

- When adjusting speed with the speed control valve, gradually open the needle from closed and raise speed. The piston rod may suddenly pop out and create a hazard if speed is adjusted while the needle is open.
- The piston rod may pop out if operation is started while the exhaust side is at atmospheric pressure. Pressurize the exhaust side before starting.
- Switch rails are glued with industrial adhesive tape. If used in an atmosphere containing inorganic or organic solvents or water vapor, rails may peel off.
Main inorganic/organic solvent
Inorganic solvent: Sodium hydroxide, hydrochloric acid etc.
Organic solvent: Toluene, ethanol, hexane, gasoline, kerosene etc.

- Remove all oil, water, dust, etc., from the main unit (tube) before laying adhesive tape for switch rails. (Refer to precautions enclosed with the product before starting.)

- Install the speed control valve near the cylinder piping port. Otherwise, speed cannot be controlled.

- Provide a separate shock absorber if the specifications (allowable energy absorption) are exceeded.

During Use & Maintenance

CAUTION

- When disassembling the cylinder, hold the across flats section of head cover or rod cover with a vise, etc., and attach a spanner or adjustable spanner, etc., on the across flats section of the other cover. Loosen and remove the cover.

When retightening the "LB" foot bracket, tighten so brackets on both sides have no play. When using other than an "LB" foot bracket, retighten from the position set before disassembly.

SCP*2
CMK2
CMA2
SCM
SCG
SCA2
SCS
CKV2
CA/OV2
SSD
CAT
MDC2
MVC
SMD2
MSD*
FC*
STK
ULK*
JSK/M2
JSG
JSC3
USSD
USC
JSB3
LMB
STG
STS/L
LCS
LCG
LCM
LCT
LCY
STR2
UCA2
HCM
HCA
SRL2
SRG
SRM
SRT
MRL2
MRG2
SM-25
CAC3
UCAC
RCC2
MFC
SHC
GLC
Ending



High energy absorption cylinder Double acting single rod type

HCM Series

● Bore size: ϕ 20, ϕ 25, ϕ 32, ϕ 40, ϕ 50, ϕ 63

JIS symbol



Specifications

Descriptions		HCM					
Bore size	mm	ϕ 20	ϕ 25	ϕ 32	ϕ 40	ϕ 50	ϕ 63
Actuation		Double acting					
Working fluid		Compressed air					
Max. working pressure	MPa	1.0					
Min. working pressure	MPa	0.15					
Withstanding pressure	MPa	1.6					
Ambient temperature	°C	-10 to 60 (no freezing)					
Port size		Rc1/8	Rc1/8	Rc1/4	Rc1/4	Rc3/8	Rc3/8
Stroke tolerance	mm	$+2.0$ 0			$+2.0$ 0		
Working piston speed	mm/s	50 to 2000 (Use within the allowable energy absorption.)					
Cushion		Air cushioned					
Lubrication		Not required (when lubricating, use turbine oil Class 1 ISOVG32)					
Allowable energy absorption J	Note 1 Air cushioned	3	5	9	14	23	30
Effective cushion length	mm	56.5	56.5	56.5	55.5	58.5	58.5

Note 1: When kinetic energy exceeds this value, consider installing an external shock absorber.
Please refer to pages 1970 to 1973 about energy calculation/size selection.

Stroke length

Bore size (mm)	Standard stroke length (mm)	Max. stroke length (mm)	Min. stroke length (mm)
ϕ 20	200 to 700	700	1
ϕ 25			
ϕ 32			
ϕ 40	200 to 1000	1000	
ϕ 50			
ϕ 63			

Note 1: Custom stroke length is available per 1mm increment.
Note 2: Consult with CKD about stroke length other than above.

Note 3: The stroke is available from 1mm. However, this product's cushion area is longer than a typical cylinder so that a high energy can be absorbed. Thus, the cushion is applied in the following strokes, and an effect for use at a high-speed will not be achieved.

Model no.	Stroke which effect of high-speed cannot be anticipated.	Recommended stroke length
HCM	150mm stroke or less	300mm stroke and over

Switch quantity and min. stroke length (mm)

Switch quantity	1		2		3		4		5	
	Proximity	Reed	Proximity	Reed	Proximity	Reed	Proximity	Reed	Proximity	Reed
ϕ 20	10		25		40	50	55		75	85
ϕ 25	10		25		40	50	55		75	85
ϕ 32	10		25		40	50	55		75	85
ϕ 40	10		25		40	50	55		75	85
ϕ 50	10		25		40	50	55		75	85
ϕ 63	10		25		40	50	55		75	85

Switch specifications

● 1 color/2 color indicator/strong magnetic field proof

*The T0/T5 switch can be used with 220 VAC .
Contact CKD for conditions.

Descriptions	Proximity 2 wire			Proximity 3 wire			Reed 2 wire						
	T1H/T1 V	T2H/T2V/ T2JH/T2JV	T2YH/ T2YV	T3H/ T3V	T3PH/T3PV (Custom order)	T3YH/ T3YV	T0H/T0V		T5H/T5V		T8H/T8V		
Applications	Programmable controller relay, small solenoid valve	Programmable controller		Programmable controller, relay			Programmable controller, relay		Programmable controller, relay IC circuit (without light), serial connection		Programmable controller, relay		
Output method	-			NPN output	PNP output	NPN output	-						
Power voltage	-			10 to 28 VDC			-						
Load voltage	85 to 265 VAC	10 to 30 VDC		30 VDC or less			12/24 VDC	110 VAC	5/12/24 VDC	110 VAC	12/24 VDC	110 VAC	220 VAC
Load current	5 to 100mA	5 to 20mA (Note 1)		100mA or less		50mA or less	5 to 50mA	7 to 20mA	50mA or less	20mA or less	5 to 50mA	7 to 20mA	7 to 10mA
Light	LED (ON lighting)	LED (ON lighting)	Red/green LED (ON lighting)	LED (ON lighting)	Green LED (ON lighting)	Red/green LED (ON lighting)	LED (ON lighting)		Without indicator light		LED (ON lighting)		
Leakage current	1mA or less with 100 VAC 2mA or less with 200 VAC	1mA or less		10 μA or less			0mA						

● With preventive maintenance output

Descriptions	Proximity 3 wire		Proximity 4 wire		Proximity 3 wire		Proximity 4 wire		
	T2YFH/V		T3YFH/V		T2YMH/V		T3YMH/V		
Applications	Programmable controller		Programmable controller, relay		Programmable controller		Programmable controller, relay		
Output method	NPN output								
Light	Red/green LED (ON lighting)								
	Yellow LED (ON lighting)								
Output section	Power voltage	-		10 to 28 VDC		-		10 to 28 VDC	
	Load voltage	10 to 30 VDC		30 VDC or less		10 to 30 VDC		30 VDC or less	
	Load current	5 to 20mA		50mA or less		5 to 20mA		50mA or less	
	Leakage current	1mA or less		10 μA or less		1.2mA or less		10 μA or less	
Preventive maintenance output	30 VDC or less								
	Load current	20mA or less		50mA or less		5 to 20mA or less		50mA or less	
	Leakage current	10 μA or less							

Note 1: Refer to Ending 1 for other switch specifications.

Note 2: Max. load current: 20mA above is the value at 25°C . When ambient temperature around a switch is higher than 25°C , the value is lower than 20mA. (5 to 10mA at 60°C)

● Strong magnetic field proof

Descriptions	Proximity switch	
	T2YD	
Applications	Programmable controller	
Light	Red/green LED (ON lighting)	
Load voltage	24 VDC ±10%	
Load current	5 to 20mA	
Internal voltage drop	6V or less	
Leakage current	1.0mA or less	

Cylinder weight

(Unit: kg)

Bore size	(mm)	φ 20	φ 25	φ 32	φ 40	φ 50	φ 63
Product weight when stroke length 0mm	Basic type 00	0.33	0.47	0.62	0.98	1.58	2.27
	Axial foot type LB	0.44	0.6	0.78	1.2	2.06	2.99
	Flange type FA/FB	0.36	0.51	0.68	1.06	1.92	2.77
Switch weight (per 1 pc.)		0.018					
Additional weight per stroke length 100 mm without switch		0.012	0.016	0.017	0.027	0.040	0.044
Additional weight per stroke length 100 mm with switch rail		0.014	0.018	0.019	0.029	0.042	0.046

(Example of calculation)

Product weight of HCM-LB-40B-500-T2H-D

Product weight when stroke length 0mm 1.2kg
 Additional weight when stroke length 500mm $0.029 \times \frac{500}{100} = 0.145\text{kg}$
 Weight of two switches $0.018 \times 2 = 0.036\text{kg}$
 Product weight $1.2 + 0.145 + 0.036 = 1.381\text{kg}$

SCP*2
CMK2
CMA2
SCM
SCG
SCA2
SCS
CKV2
CA/OV2
SSD
CAT
MDC2
MVC
SMD2
MSD*
FC*
STK
ULK*
JSK/M2
JSG
JSC3
USSD
USC
JSB3
LMB
STG
STS/L
LCS
LCG
LCM
LCT
LCY
STR2
UCA2
HCM
HCA
SRL2
SRG
SRM
SRT
MRL2
MRG2
SM-25
CAC3
UCAC
RCC2
MFC
SHC
GLC

Ending

High energy absorption cylinder
High-speed type

How to order

Without switch

HCM - **LB** - **40** - **B** - **500** - **I**

With switch

HCM - **LB** - **40** - **B** - **500** - **T2H*** - **D** - **Q** - **I**

A Mounting style

Note 1

B Bore size

C Port thread type

D Cushion

E Stroke length

F Switch model no.

Note 2

G Switch quantity

H Option

I Accessory

Note 3

Symbol	Descriptions	
A Mounting style		
00	Basic type	
LB	Axial foot type	
FA	Rod end flange type	
FB	Head end flange type	
B Bore size (mm)		
20	φ 20	
25	φ 25	
32	φ 32	
40	φ 40	
50	φ 50	
63	φ 63	
C Port thread type		
Blank	Rc thread	
N	NPT thread (custom order)	
G	G thread (custom order)	
D Cushion		
B	Both sides cushioned	
R	Rod end cushion	
H	Head end cushion	
N	No cushion	
E Stroke length (mm)		
Bore size	Stroke length	Custom stroke length
φ20 to φ32	1 to 700	By 1 mm increment
φ40 to φ63	1 to 1000	
F Switch model no.		
Axial lead wire	Radial lead wire	Contact
T0H*	T0V*	Reed
T5H*	T5V*	
T8H*	T8V*	
T1H*	T1V*	Proximity
T2H*	T2V*	
T3H*	T3V*	
T3PH*	T3PV*	
T2YH*	T2YV*	
T3YH*	T3YV*	
T2YFH*	T2YFV*	
T3YFH*	T3YFV*	
T2YMH*	T2YMV*	
T3YMH*	T3YMV*	
T2YD*	-	Strong magnetic field proof switch
T2YDT*	-	
T2JH*	T2JV*	Off-delay type
*Lead wire length		
Blank	1m (standard)	
3	3m (option)	
5	5m (option)	
G Switch quantity		
R	One on rod end	
H	One on head end	
D	Two	
T	Three	
4	Four	
5	Five	
H Option		
Q	Switch rail attached at shipment	
M	Piston rod material (stainless steel)	
I Accessory		
I	Rod eye	
Y	Rod clevis (pin and snap ring attached)	

Note on model no. selection

Note 1: The mounting bracket is shipped with the product.

Note 2: Switches other than **F** switch model no. are available. (Custom order) Refer to Ending 1 for details.

Note 3: "I" and "Y" can not be selected at the same time.

<Example of model number>

HCM-LB-40B-500-T2H-D-QI

Model: High energy absorption cylinder double acting

- A** Mounting style : axial foot type
- B** Bore size : φ 40mm
- C** Port thread type : Rc thread
- D** Cushion : both sides cushioned
- E** Stroke length : 500mm
- F** Switch model no. : proximity T2H switch, lead wire 1m
- G** With switch quantity : 2
- H** Option : Switch rail attached at shipment
- I** Accessory : rod eye

SCP*2
CMK2
CMA2
SCM
SCG
SCA2
SCS
CKV2
CA/OV2
SSD
CAT
MDC2
MVC
SMD2
MSD*
FC*
STK
ULK*
JSK/M2
JSG
JSC3
USSD
USC
JSB3
LMB
STG
STS/L
LCS
LCG
LCM
LCT
LCY
STR2
UCA2
HCM
HCA
SRL2
SRG
SRM
SRT
MRL2
MRG2
SM-25
CAC3
UCAC
RCC2
MFC
SHC
GLC
Ending

How to order switch discrete

● Switch body + mounting rail set

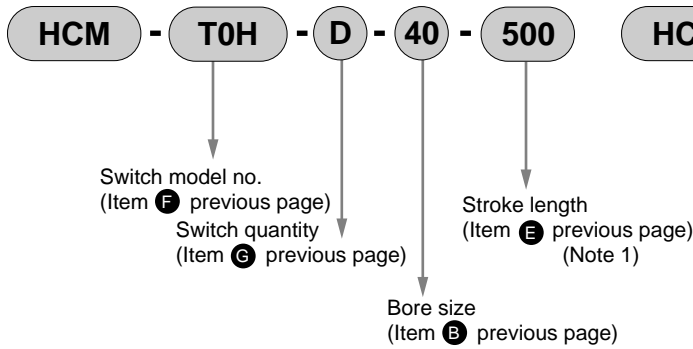

● Mounting rail only

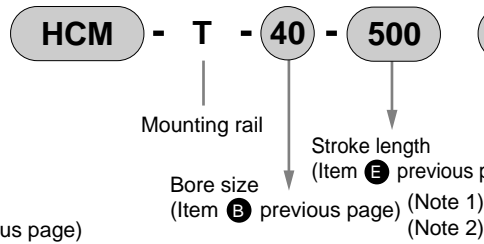

● Switch only

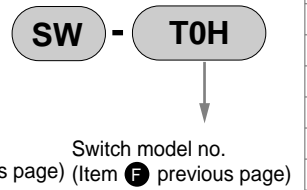

Note 1: Indicate X if the stroke exceeds 300 mm.

One short rail (switch adjustment and movement distance 100 mm) is provided with each switch when the stroke exceeds 300 mm.

Note 2: When indicating only X for the mounting rail, order the same number of rails as the number of switches being used.

Mounting bracket model no.

Bore size Mounting style	Foot (LB)	Flange (FA/FB)
φ 20	HCM-LB-20	HCM-FA-20
φ 25	HCM-LB-25	HCM-FA-25
φ 32	HCM-LB-32	HCM-FA-32
φ 40	HCM-LB-40	HCM-FA-40
φ 50	HCM-LB-50	HCM-FA-50
φ 63	HCM-LB-63	HCM-FA-63

Note 1: The foot type mounting bracket is supplied as a two-piece set.

SCP*2
CMK2
CMA2
SCM
SCG
SCA2
SCS
CKV2
CA/OV2
SSD
CAT
MDC2
MVC
SMD2
MSD*
FC*
STK
ULK*
JSK/M2
JSG
JSC3
USSD
USC
JSB3
LMB
STG
STS/L
LCS
LCG
LCM
LCT
LCY
STR2
UCA2
HCM
HCA
SRL2
SRG
SRM
SRT
MRL2
MRG2
SM-25
CAC3
UCAC
RCC2
MFC
SHC
GLC
Ending

High energy absorption cylinder
High-speed type

Internal structure and parts list

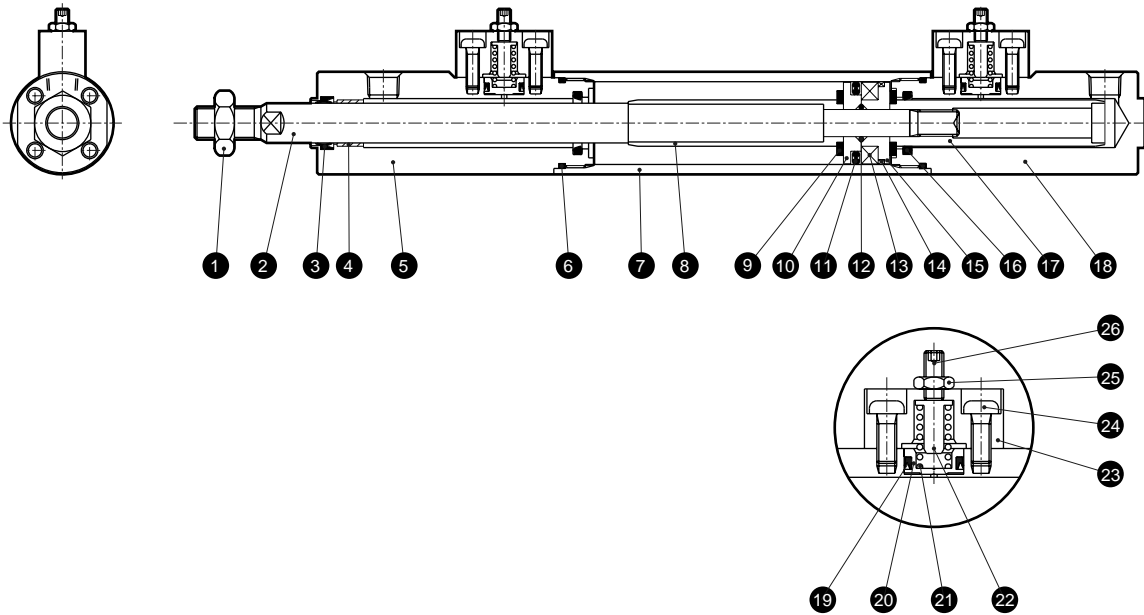

No.	Parts name	Material	Remarks	No.	Parts name	Material	Remarks
1	Rod nut	Steel	Nickeling	14	Wear ring	Resin	
2	Piston rod	ϕ 20, ϕ 25: stainless steel ϕ 32 to ϕ 63: steel	Industrial chrome plating	15	Piston (H)	Aluminum alloy	Chromate treatment
3	Rod packing seal	Special nitrile rubber		16	Cushion packing seal	ϕ 20 to ϕ 32: urethane ϕ 40 to ϕ 63: urethane, steel	
4	Bush	Oil impregnated bearing alloy		17	Cushion ring (H)	Aluminum alloy	Chromate treatment
5	Rod cover	Aluminum alloy	Black alumite	18	Head cover	Aluminum alloy	Black alumite
6	Cylinder gasket	Nitrile rubber		19	Relief valve packing seal	Nitrile rubber	
7	Cylinder tube	Aluminum alloy	Hard alumite	20	Relief valve	Copper alloy	
8	Cushion ring (R)	Aluminum alloy	Chromate treatment	21	Spring	Steel	Electrodeposition coating
9	Cushion rubber	Urethane rubber		22	Collar for spring	Steel	Chromate treatment
10	Piston (R)	Aluminum alloy	Chromate treatment	23	Relief valve holder	Aluminum alloy	Black alumite
11	Piston packing seal	Special nitrile rubber		24	Cross headed pan	Steel	Blackening
12	Piston gasket	Nitrile rubber	ϕ 25 to ϕ 63	25	Hexagon nut	Steel	Blackening
13	Magnet	Plastic		26	Hexagon socket head set screw	Steel	Blackening

Repair parts list

Bore size (mm)	Kit No.	Repair parts number
ϕ 20	HCM-20K	
ϕ 25	HCM-25K	
ϕ 32	HCM-32K	3 6 9 11 14
ϕ 40	HCM-40K	16 19
ϕ 50	HCM-50K	
ϕ 63	HCM-63K	

Note: Specify the kit No. when placing an order.

Mounting bracket material and treatment

Mounting style	Material	Treatment
LB	Steel	Zinc chromate
FA/FB	ϕ 20 to ϕ 40	Aluminum alloy
	ϕ 50, ϕ 63	Steel

Dimensions



● Basic type (00)

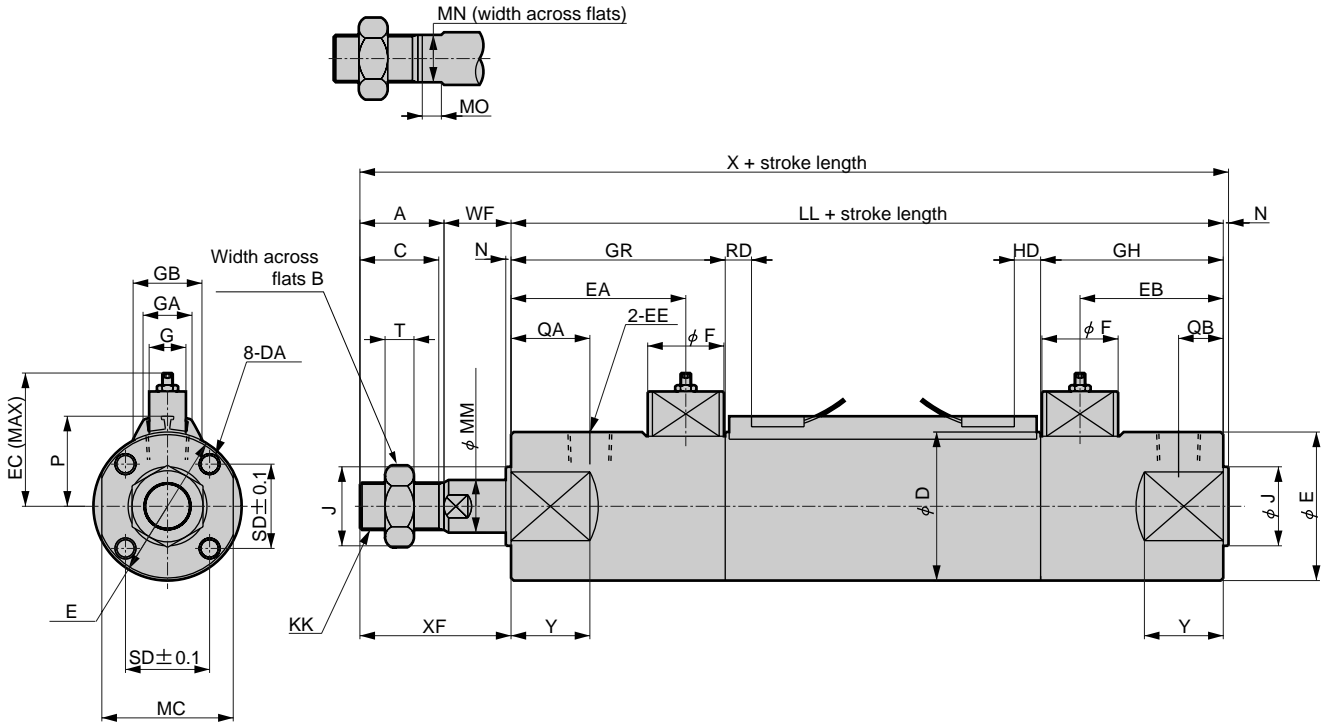

Symbol	A	B	C	D	DA	E	EA	EB	EC	EE	F	G	J	KK	LL	MC	MM	MN	MO	N	
Bore size																					
φ 20	18	13	16	26	M4 depth 8	28	52	43	32.7	Rc1/8	29	14	13	M8	164	24	10	8	5	2	
φ 25	20	17	18	31	M5 depth 9	31	56.5	47.5	34.5	Rc1/8	29	14	15	M10X1.25	173	27	12	10	6	2	
φ 32	20	17	18	37	M5 depth 9	37	56.5	47.5	37.8	Rc1/4	29	14	18	M10X1.25	173	32	12	10	6	2	
φ 40	26	22	24	46	M6 depth 10	46	62	51	47.3	Rc1/4	29	14	25	M14X1.5	186	41	16	14	7	2	
φ 50	32	27	30	56.4	M8 depth 12	56.4	66.5	54.5	52.6	Rc3/8	29	14	30	M18X1.5	196	50	20	17	8	2	
φ 63	32	27	30	69.4	M10 depth 15	69.4	66.5	54.5	59.3	Rc3/8	29	14	32	M18X1.5	196	60	20	17	8	2	
Symbol	QA	QB	SD	T	WF	X	XF	Y	GR	GH	GA	GB	P	T0/T5		T8		T2/T3		T1/T2Y/T3Y	
Bore size														RD	HD	RD	HD	RD	HD	RD	HD
φ 20	18	10	14	5	15.5	199.5	33.5	20	67	58	18	23	19.5	9.5	9	3.5	3	10	10	9.5	9
φ 25	20	10	16.5	6	17	212	37	20	71.5	62.5	18	24.4	22	10	8	4	2	11	9	10	8
φ 32	20	12	20	6	17	212	37	28	71.5	62.5	18	25	25	10	8	4	2	11	9	10	8
φ 40	26	14	26	8	20.5	234.5	46.5	28	77	66	18	25.7	29.5	12	10.5	6	4.5	13	11	12	10.5
φ 50	30	17	32	11	25.5	255.5	57.5	30	81.5	69.5	18	26.2	34.7	13	11.5	7	5.5	14	12	13	11.5
φ 63	30	17	38	11	25.5	255.5	57.5	30	81.5	69.5	18	26.5	41.2	13	11.5	7	5.5	14	12	13	11.5

Note 1: Only for φ 20, tube outer diameter D and cover outer diameter E are different.
 Note 2: Refer to page 1969 for dimensions of accessory.

- SCP*2
- CMK2
- CMA2
- SCM
- SCG
- SCA2
- SCS
- CKV2
- CA/OV2
- SSD
- CAT
- MDC2
- MVC
- SMD2
- MSD*
- FC*
- STK
- ULK*
- JSK/M2
- JSG
- JSC3
- USSD
- USC
- JSB3
- LMB
- STG
- STS/L
- LCS
- LCG
- LCM
- LCT
- LCY
- STR2
- UCA2
- HCM**
- HCA
- SRL2
- SRG
- SRM
- SRT
- MRL2
- MRG2
- SM-25
- CAC3
- UCAC
- RCC2
- MFC
- SHC
- GLC
- Ending

High energy absorption cylinder
High-speed type

Dimensions



● Axial foot type (LB)

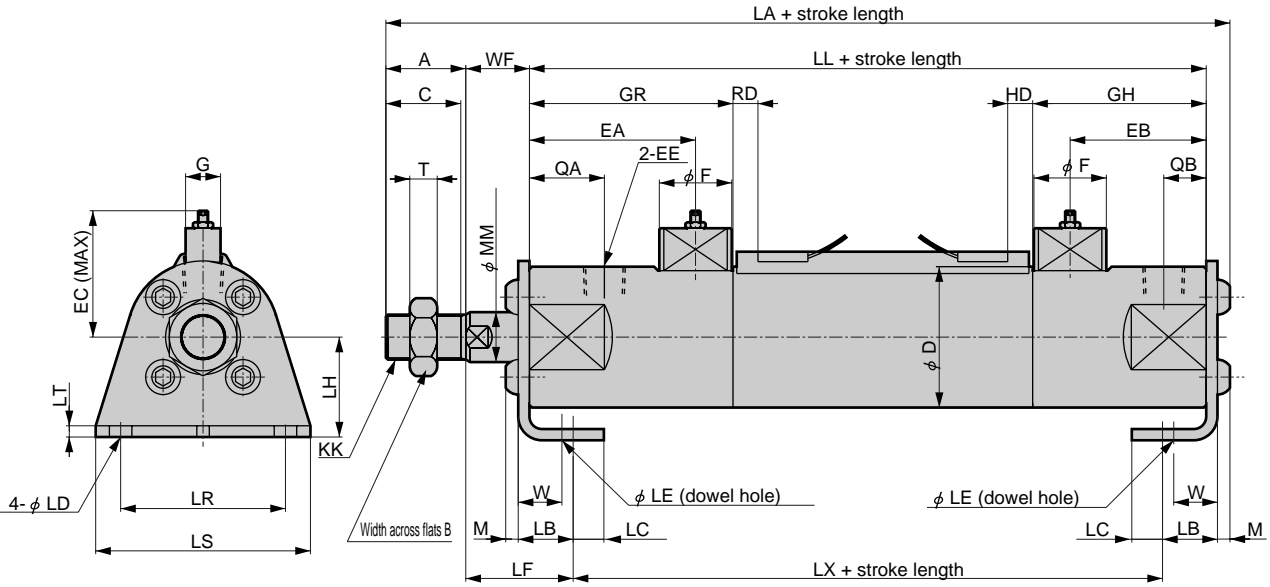

Symbol	A	B	C	D	EA	EB	EC	EE	F	G	KK	LA	LB	LC	LD	LE	LF	LH	LL		
Bore size																					
φ 20	18	13	16	26	52	43	32.7	Rc1/8	29	14	M8	203.3	15.1	7.1	5.7	4	27	20	164		
φ 25	20	17	18	31	56.5	47.5	34.5	Rc1/8	29	14	M10X1.25	216.6	15.1	7.1	5.7	4	28.9	22	173		
φ 32	20	17	18	37	56.5	47.5	37.8	Rc1/4	29	14	M10X1.25	216.6	16.1	8.1	6.8	4	29.9	25	173		
φ 40	26	22	24	46	62	51	47.3	Rc1/4	29	14	M14X1.5	239.7	16.6	9.1	6.8	4	33.9	30	186		
φ 50	32	27	30	56.4	66.5	54.5	52.6	Rc3/8	29	14	M18X1.5	263	22	11	9	5	43	40	196		
φ 63	32	27	30	69.4	66.5	54.5	59.3	Rc3/8	29	14	M18X1.5	263	22	13	11	5	43	45	196		
Symbol	LR	LS	LT	LX	M	MM	QA	QB	T	W	WF	GR	GH	T0/T5		T8		T2/T3		T1/T2Y/T3Y	
Bore size														RD	HD	RD	HD	RD	HD	RD	HD
φ 20	32	44	3.2	140.2	2.6	10	18	10	5	10	15.5	67	58	9.5	9	3.5	3	10	10	9.5	9
φ 25	36	49	3.2	149.2	3.4	12	20	10	6	10	17	71.5	62.5	10	8	4	2	11	9	10	8
φ 32	44	58	3.2	147.2	3.4	12	20	12	6	10	17	71.5	62.5	10	8	4	2	11	9	10	8
φ 40	54	71	3.2	159.2	4	16	26	14	8	10	20.5	77	66	12	10.5	6	4.5	13	11	12	10.5
φ 50	66	86	4.5	161	5	20	30	17	11	17.5	25.5	81.5	69.5	13	11.5	7	5.5	14	12	13	11.5
φ 63	82	106	4.5	161	5	20	30	17	11	17.5	25.5	81.5	69.5	13	11.5	7	5.5	14	12	13	11.5

Note 1: Refer to page 1969 for dimensions of accessory.

Dimensions



- Rod end flange type (FA)

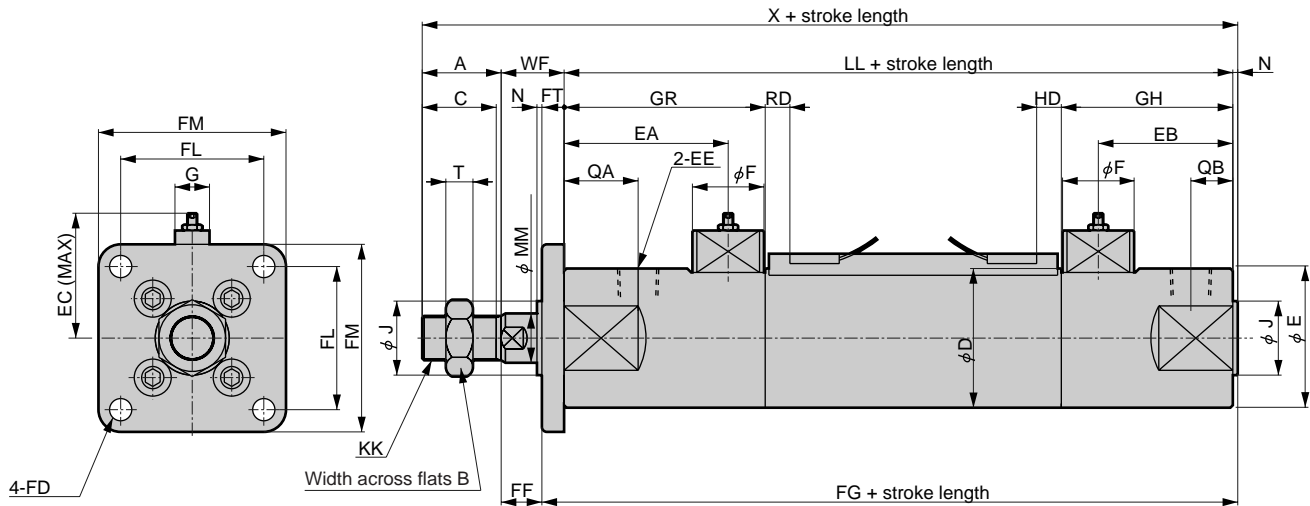

- SCP*2
- CMK2
- CMA2
- SCM
- SCG
- SCA2
- SCS
- CKV2
- CA/OV2
- SSD
- CAT
- MDC2
- MVC
- SMD2
- MSD*
- FC*
- STK
- ULK*
- JSK/M2
- JSG
- JSC3
- USSD
- USC
- JSB3
- LMB
- STG
- STS/L
- LCS
- LCG
- LCM
- LCT
- LCY
- STR2
- UCA2
- HCM**
- HCA
- SRL2
- SRG
- SRM
- SRT
- MRL2
- MRG2
- SM-25
- CAC3
- UCAC
- RCC2
- MFC
- SHC
- GLC
- Ending

Symbol	A	B	C	D	E	EA	EB	EC	EE	F	FD	FF	FG	FL	FM	FT	G	J	KK	LL
Bore size																				
φ 20	18	13	16	26	28	52	43	32.7	Rc1/8	29	5.5	9.5	172	28	40	6	14	13	M8	164
φ 25	20	17	18	31	31	56.5	47.5	34.5	Rc1/8	29	5.5	10	182	32	44	7	14	15	M10X1.25	173
φ 32	20	17	18	37	37	56.5	47.5	37.8	Rc1/4	29	6.6	10	182	38	53	7	14	18	M10X1.25	173
φ 40	26	22	24	46	46	62	51	47.3	Rc1/4	29	6.6	12.5	196	46	61	8	14	25	M14X1.5	186
φ 50	32	27	30	56.4	56.4	66.5	54.5	52.6	Rc3/8	29	9	16.5	207	58	76	9	14	30	M18X1.5	196
φ 63	32	27	30	69.4	69.4	66.5	54.5	59.3	Rc3/8	29	11	16.5	207	70	92	9	14	32	M18X1.5	196
Symbol	MM	N	QA		QB		T	WF	X	GR	GH	T0/T5		T8		T2/T3		T1/T2Y/T3Y		
Bore size												RD	HD	RD	HD	RD	HD	RD	HD	
φ 20	10	2	18		10		5	15.5	199.5	67	58	9.5	9	3.5	3	10	10	9.5	9	
φ 25	12	2	20		10		6	17	212	71.5	62.5	10	8	4	2	11	9	10	8	
φ 32	12	2	20		12		6	17	212	71.5	62.5	10	8	4	2	11	9	10	8	
φ 40	16	2	26		14		8	20.5	234.5	77	66	12	10.5	6	4.5	13	11	12	10.5	
φ 50	20	2	30		17		11	25.5	255.5	81.5	69.5	13	11.5	7	5.5	14	12	13	11.5	
φ 63	20	2	30		17		11	25.5	255.5	81.5	69.5	13	11.5	7	5.5	14	12	13	11.5	

Note 1: Refer to page 1969 for dimensions of accessory.

High energy absorption cylinder
High-speed type

Dimensions



● Head end flange type (FB)

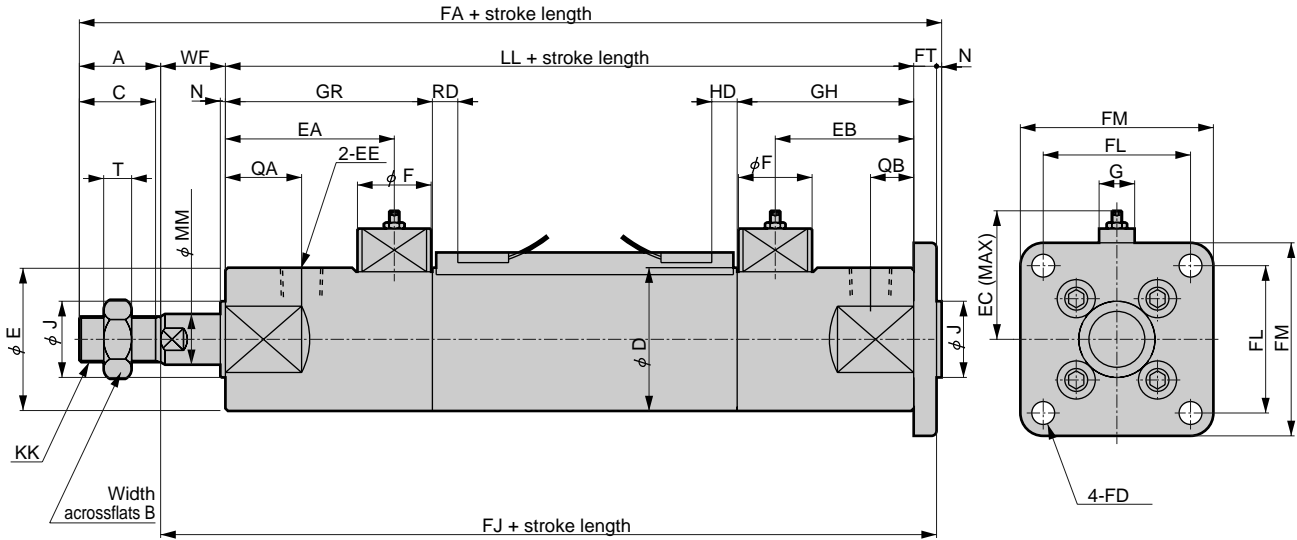

Symbol	A	B	C	D	E	EA	EB	EC	EE	F	FA	FD	FJ	FL	FM	FT	G	J	KK
Bore size																			
φ 20	18	13	16	26	28	52	43	32.7	Rc1/8	29	205.5	5.5	185.5	28	40	6	14	13	M8
φ 25	20	17	18	31	31	56.5	47.5	34.5	Rc1/8	29	219	5.5	197	32	44	7	14	15	M10X1.25
φ 32	20	17	18	37	37	56.5	47.5	37.8	Rc1/4	29	219	6.6	197	38	53	7	14	18	M10X1.25
φ 40	26	22	24	46	46	62	51	47.3	Rc1/4	29	242.5	6.6	214.5	46	61	8	14	25	M14X1.5
φ 50	32	27	30	56.4	56.4	66.5	54.5	52.6	Rc3/8	29	264.5	9	230.5	58	76	9	14	30	M18X1.5
φ 63	32	27	30	69.4	69.4	66.5	54.5	59.3	Rc3/8	29	264.5	11	230.5	70	92	9	14	32	M18X1.5
Symbol	LL	MM	N	QA	QB	T	WF	GR	GH	T0/T5		T8		T2/T3		T1/T2Y/T3Y			
Bore size										RD	HD	RD	HD	RD	HD	RD	HD		
φ 20	164	10	2	18	10	5	15.5	67	58	9.5	9	3.5	3	10	10	9.5	9		
φ 25	173	12	2	20	10	6	17	71.5	62.5	10	8	4	2	11	9	10	8		
φ 32	173	12	2	20	12	6	17	71.5	62.5	10	8	4	2	11	9	10	8		
φ 40	186	16	2	26	14	8	20.5	77	66	12	10.5	6	4.5	13	11	12	10.5		
φ 50	196	20	2	30	17	11	25.5	81.5	69.5	13	11.5	7	5.5	14	12	13	11.5		
φ 63	196	20	2	30	17	11	25.5	81.5	69.5	13	11.5	7	5.5	14	12	13	11.5		

Note 1: Only for φ 20, tube outer diameter D and cover outer diameter E are different.
 Note 2: Refer to page 1969 for dimensions of accessory.

Accessory dimensions

Rod eye

- HCM-I- ϕ 20 to ϕ 25

Material: Steel

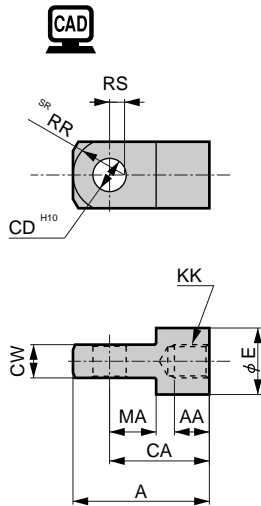

- HCM-I- ϕ 40 to ϕ 63

Material: Cast iron

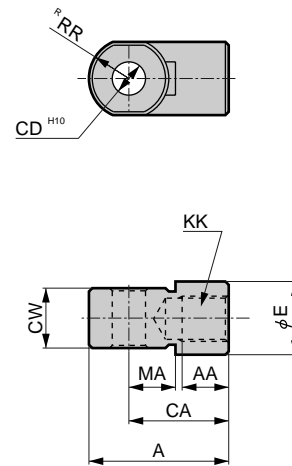

Model no.	Applicable bore size (mm)	A	AA	CA	CD	CW	E	KK	MA	RR	RS	Weight (g)
HCM-I-20	20	34	8.5	25	$8^{+0.058}_0$	$8^{-0.2}_{-0.4}$	16	M8	11.5	13.4	3.1	39
HCM-I-25	25, 32	41	10.5	30	$10^{+0.058}_0$	$10^{-0.2}_{-0.4}$	20	M10 x 1.25	14	17.1	4.5	72
HCM-I-40	40	42	14	30	$10^{+0.058}_0$	$18^{-0.3}_{-0.5}$	22	M14 x 1.5	14	12	-	152
HCM-I-50	50, 63	56	18	40	$14^{+0.070}_0$	$22^{-0.3}_{-0.5}$	28	M18 x 1.5	20	16	-	158

Rod clevis

- HCM-Y- ϕ 20 to ϕ 25

Material: Steel

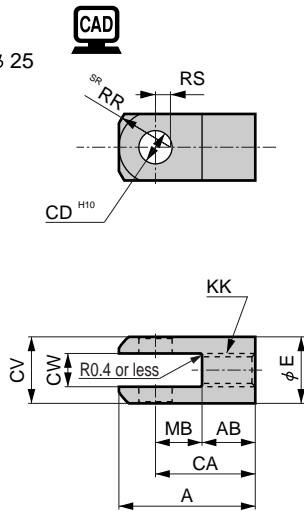

- HCM-Y- ϕ 40 to ϕ 63

Material: Cast iron

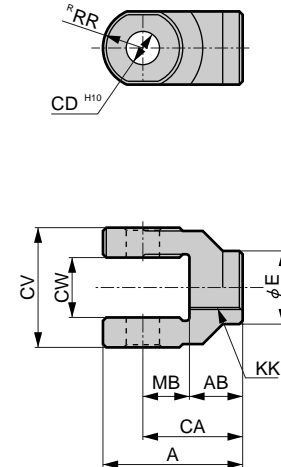

Model no.	Applicable bore size (mm)	A	AB	CA	CD	CV	CW	E	KK	MB	RR	RS	Weight (g)	Applicable pin model no.
HCM-Y-20	20	34	13.5	25	$8^{+0.058}_0$	16	$8^{+0.2}_{+0.4}$	16	M8	11.5	13.4	3.1	46	HCM-P-20
HCM-Y-25	25, 32	41	16	30	$10^{+0.058}_0$	20	$10^{+0.2}_{+0.4}$	20	M10 x 1.25	14	17.1	4.5	85	HCM-P-25
HCM-Y-40	40	42	16	30	$10^{+0.058}_0$	36	$18^{+0.3}_{+0.5}$	22	M14 x 1.5	14	12	-	122	HCM-P-40
HCM-Y-50	50, 63	56	20	40	$14^{+0.070}_0$	44	$22^{+0.3}_{+0.5}$	28	M18 x 1.5	20	16	-	258	HCM-P-50

Note: A pin and a snap ring are attached to rod clevis.

Pin for rod eye/clevis

Material: Steel

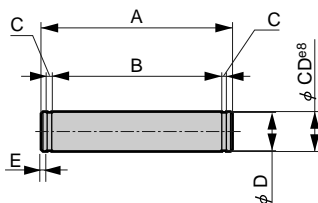

Model no.	Applicable bore size (mm)	A	B	C	CD	D	E	Weight (g)	Applicable snap rings
HCM-P-20	20	21	16.2	0.9	$8^{-0.025}_{-0.047}$	7.6	1.5	8.6	Axis C type 8
HCM-P-25	25, 32	25.6	20.2	1.15	$10^{-0.025}_{-0.047}$	9.6	1.6	16	Axis C type 10
HCM-P-40	40	41.6	36.2	1.15	$10^{-0.025}_{-0.047}$	9.6	1.6	26	Axis C type 10
HCM-P-50	50, 63	50.6	44.2	1.15	$14^{-0.032}_{-0.056}$	13.4	2.1	60	Axis C type 14

Note: A pin and a snap ring are attached to rod clevis.

SCP*2
CMK2
CMA2
SCM
SCG
SCA2
SCS
CKV2
CA/OV2
SSD
CAT
MDC2
MVC
SMD2
MSD*
FC*
STK
ULK*
JSK/M2
JSG
JSC3
USSD
USC
JSB3
LMB
STG
STS/L
LCS
LCG
LCM
LCT
LCY
STR2
UCA2
HCM
HCA
SRL2
SRG
SRM
SRT
MRL2
MRG2
SM-25
CAC3
UCAC
RCC2
MFC
SHC
GLC

Ending

High energy absorption cylinder
High-speed type

Cylinder and system selection guide

Some values may vary depending on conditions. Use following values as reference.

STEP-1 Confirming working conditions

- (1) Load weight M (kg)
- (2) Stroke length St (mm)
- (3) Moving time T (s)
- (4) Cylinder average speed V0 (m/s)
 $V0 = St / (T \times 1000)$
- (5) Working pressure P (MPa)
- (6) Installation method/direction

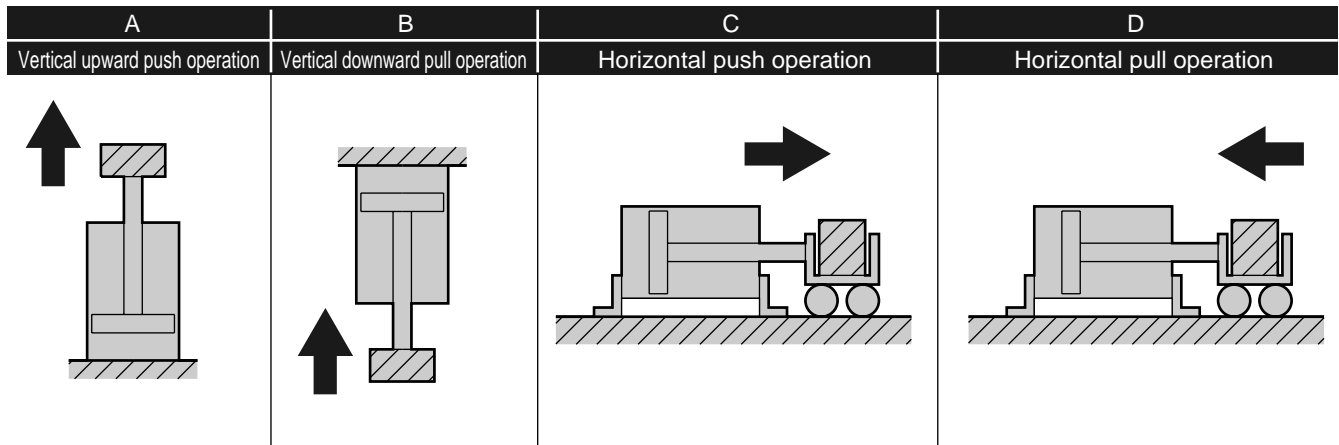

Note: When lifting downward vertically, cylinder thrust is almost no required. Select the cylinder size according to lifting upward that requires thrust.

STEP-2 Roughly selecting cylinder size

- (1) Please set load factor (α) according to piston speed.

When high speed operation (1 to 2m/s), $\alpha = 20\%$

When medium speed operation (1 m/s or less), $\alpha = 50\%$

- (2) Calculate required cylinder thrust (F).

$$F (N) = \frac{980 \times M \times \mu}{\alpha}$$

M : load weight (kg)

α : Load factor (%)

μ : coefficient of friction

Installation method C/D horizontal rolling = 0.1

Installation method A/B vertical upside down = 1

- (3) Please find cylinder bore size (D).

$$D(\text{mm}) = \sqrt{\frac{F}{0.25 \times P \times \pi}}$$

P: Working pressure (MPa)

F: Required cylinder thrust (N)

- (4) Select the size larger than the value found at (3).

Size	Cylinder bore size (mm)
$\phi 20$	20
$\phi 25$	25
$\phi 32$	32
$\phi 40$	40
$\phi 50$	50
$\phi 63$	63

SCP*2
CMK2
CMA2
SCM
SCG
SCA2
SCS
CKV2
CA/OV2
SSD
CAT
MDC2
MVC
SMD2
MSD*
FC*
STK
ULK*
JSK/M2
JSG
JSC3
USSD
USC
JSB3
LMB
STG
STS/L
LCS
LCG
LCM
LCT
LCY
STR2
UCA2
HCM
HCA
SRL2
SRG
SRM
SRT
MRL2
MRG2
SM-25
CAC3
UCAC
RCC2
MFC
SHC
GLC
Ending

SCP*2
CMK2
CMA2
SCM
SCG
SCA2
SCS
CKV2
CA/OV2
SSD
CAT
MDC2
MVC
SMD2
MSD*
FC*
STK
ULK*
JSK/M2
JSG
JSC3
USSD
USC
JSB3
LMB
STG
STS/L
LCS
LCG
LCM
LCT
LCY
STR2
UCA2
HCM
HCA
SRL2
SRG
SRM
SRT
MRL2
MRG2
SM-25
CAC3
UCAC
RCC2
MFC
SHC
GLC
Ending

STEP-3 Calculation of max. speed

- Find maximum speed (V_{max}) in graph -1 according to working conditions (average speed V_0 /installation method/direction) of Step 1 and load factor α of Step 2. When maximum speed (V_{max}) exceeds 2m/s, go back to Step 1, and decrease average speed V_0 .

(Graph-1)

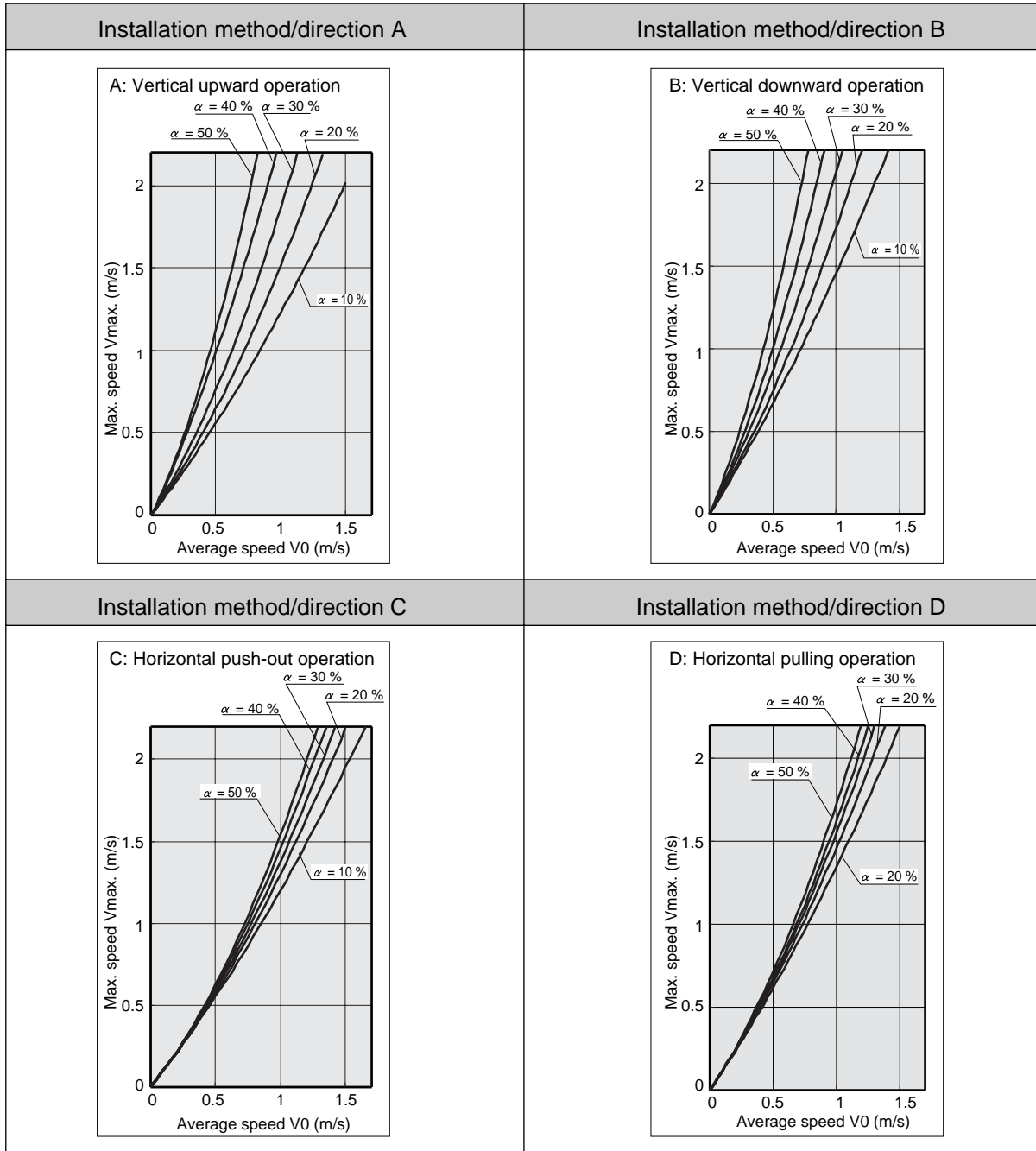

Pipe length is approximate 2m under working pressure $P=0.5$ MPa.
For other conditions, this is just reference.

High energy absorption cylinder
High-speed type

STEP-4 Confirming cushion faculty

- Check if the kinetic energy generated by movement of load is absorbed by the cylinder cushion.

Calculate kinetic energy (E1) according to load weight M of Step 1 and max. speed Vmax found at Step 3.

$$E1 (J) = 0.5 \times (V_{max})^2 \times M$$

- E1 should not be greater than allowable absorbing energy E2 on Table 1.

When $E1 > E2$, decrease average speed V_0 or install an external buffer device (shock absorber).
(Table 1)

Bore size	Allowable absorbing energy-E2 (J)
φ 20	3
φ 25	5
φ 32	9
φ 40	14
φ 50	23
φ 63	30

Note: When vertical-upward retract operation and vertical-downward extract operation, energy can be absorbed but can not be stopped smoothly. (Bouncing, etc. are generated.)

When smooth stop is necessary, as reference, load factor should be 10% or less and max. speed should be 1 m/s or less.

STEP-5 Calculation of required composite effective sectional area

Find required effective sectional area S according to max. speed Vmax found at Step 3 and cylinder bore size found at Step 2.

(Graph 2)

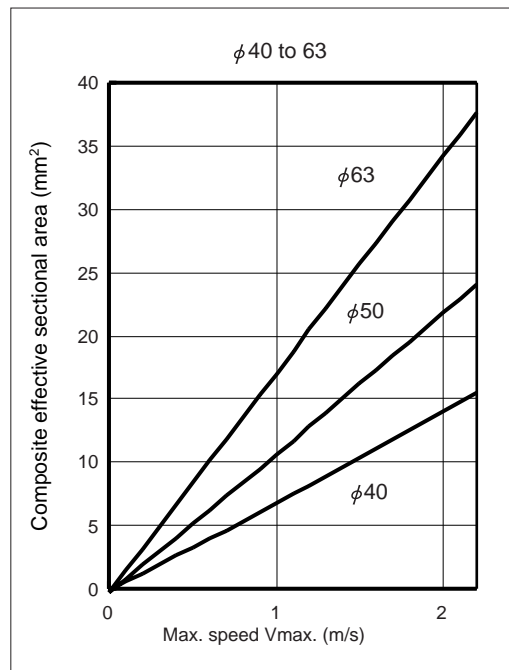
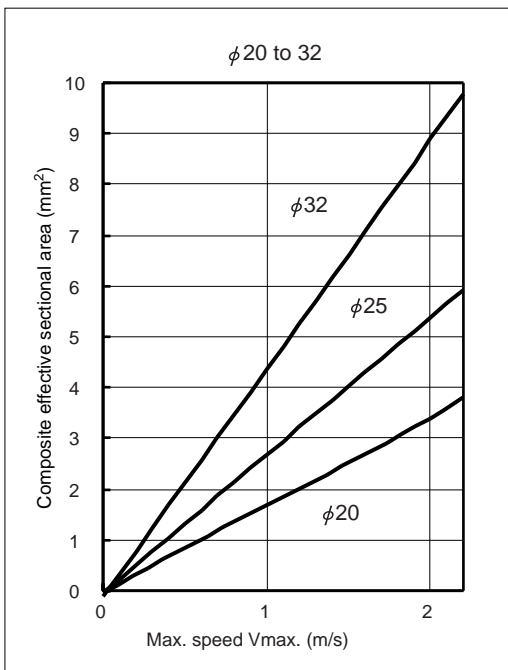

- SCP*2
- CMK2
- CMA2
- SCM
- SCG
- SCA2
- SCS
- CKV2
- CA/OV2
- SSD
- CAT
- MDC2
- MVC
- SMD2
- MSD*
- FC*
- STK
- ULK*
- JSK/M2
- JSG
- JSC3
- USSD
- USC
- JSB3
- STG
- STS/L
- LCS
- LCG
- LCM
- LCT
- LCY
- STR2
- UCA2
- HCM**
- HCA**
- SRL2
- SRG
- SRM
- SRT
- MRL2
- MRG2
- SM-25
- CAC3
- UCAC
- RCC2
- MFC
- SHC
- GLC
- Ending

High energy absorption cylinder
High-speed type

STEP-6 System circuit selection

● Using Table 2, select the system circuit according to the required composite effective sectional area found at Step 5.

(Table 2)

Symbol S in the table shows individual effective sectional area (mm²).

Composite effective cross-section areas (mm ²)	Solenoid valve								Speed controller		Silencer		Port thread (Pipe length 2m)
	Direct mounting				Sub-plate type								
	Single solenoid		Double solenoid		Single solenoid		Double solenoid		S	S			
	S	S	S	S	S	S							
1.2	4KA110-M5	3	4KA120-M5	3	4KB110-06	4	4KB120-06	4	SC3W-6-4	2.8	SLW-6A	10	φ 4 x φ 2.5
2	4KA110-M5	3	4KA120-M5	3					SC3W-6-6	3.6	SLW-6A	10	φ 6 x φ 4
2.3					4KB110-06	4	4KB120-06	4	SC3W-6-6	3.6	SLW-6A	10	φ 6 x φ 4
3.1	4KA210-06	13	4KA220-06	12.5					SC3W-6-8	3.6	SLW-6A	10	φ 8 x φ 5.7
3.2					4KB210-06	14	4KB220-06	14	SC3W-6-8	3.6	SLW-6A	10	φ 8 x φ 5.7
3.6	4KA210-06	13	4KA220-06	12.5					SC1-6	8	SLW-6A	10	φ 6 x φ 4
3.7					4KB210-06	14	4KB220-06	14	SC1-6	8	SLW-6A	10	φ 6 x φ 4
5	4KA210-06	13	4KA220-06	12.5	4KB210-06	14	4KB220-06	14	SC1-6	8	SLW-6A	10	φ 8 x φ 5.7
5.3					4KB210-08	14	4KB220-08	14	SC3W-8-8	7	SLW-8A	20	φ 8 x φ 5.7
5.9					4KB210-08	14	4KB220-08	14	SC3W-8-10	7	SLW-8A	20	φ 10 x φ 7.2
6.1	4F210-08	18	4F220-08	18					SC3W-8-10	7	SLW-8A	20	φ 10 x φ 7.2
6.4	4KA310-08	25	4KA320-08	25	4KB310-08	28	4KB320-08	28	SC3W-8-10	7	SLW-8A	20	φ 10 x φ 7.2
6.5	4KA210-06	13	4KA220-06	12.5					SC1-8	13	SLW-6A	10	φ 10 x φ 7.2
6.9					4KB210-08	14	4KB220-08	14	SC1-8	13	SLW-8A	20	φ 8 x φ 5.7
8.5					4F210-08	18	4F220-08	18	SC1-8	13	SLW-8A	20	φ 10 x φ 7.2
9	4KA310-08	25	4KA320-08	25	4KB310-08	28	4KB320-08	28	SC1-8	13	SLW-8A	20	φ 10 x φ 7.2
9.9	4F310-10	32	4F320-10	32					SC3W-10-10	15	SLW-8A	20	φ 10 x φ 7.2
10	4KA410-10	50	4KA420-10	50	4KB410-10	60	4KB420-10	60	SC3W-10-10	15	SLW-8A	20	φ 10 x φ 7.2
11	4KA410-10	50	4KA420-10	50	4KB410-10	60	4KB420-10	60	SC3W-10-12	15	SLW-8A	20	φ 12 x φ 8.9
13					4F410-10	32	4F420-10	32	SC1-10	25	SLW-8A	20	φ 12 x φ 8.9
15.8					4F510-10	47	4F520-10	47	SC1-10	25	SLW-10A	30	φ 12 x φ 8.9
17					4F510-10	47	4F520-10	47	SC1-10	25	SLW-10A	30	φ 15 x φ 11.5
19.6					4F510-10	47	4F520-10	47	SC1-15	36	SLW-10A	30	φ 15 x φ 11.5
20					4F610-15	90	4F620-15	90	SC1-15	36	SLW-15A	40	φ 12 x φ 8.9
24					4F610-15	90	4F620-15	90	SC1-15	36	SLW-15A	40	φ 15 x φ 11.5
30					4F610-15	90	4F620-15	90	SC-20A	110	SLW-15A	40	φ 15 x φ 11.5
41					4F610-15	90	4F620-15	90	SC-20A	110	SL-15A	92	φ 15 x φ 11.5
45					4F610-15	90	4F620-15	90	SC-20A	110	SL-20A	160	φ 15 x φ 11.5

(Circuit diagram)

1. Speed control valve
2. Piping
3. Solenoid valve
4. Silencer

