

# Axial space saving structure and precise guided type

- SCP\*2
- CMK2
- CMA2
- SCM
- SCG
- SCA2
- SCS
- CKV2
- CA/OV2
- SSD
- CAT
- MDC2
- MVC
- SMD2
- MSD\***
- FC\*
- STK
- ULK\*
- JSK/M2
- JSG
- JSC3
- USSD
- USC
- JSB3
- LMB
- STG
- STS/L
- LCS
- LCG
- LCM
- LCT
- LCY
- STR2
- UCA2
- HCM
- HCA
- SRL2
- SRG
- SRM
- SRT
- MRL2
- MRG2
- SM-25
- CAC3
- UCAC
- RCC2
- MFC
- SHC
- GLC
- Ending

## ● Axial space saving

Compact axial length  
Footprint reduced

## ● Long service life design (approximate 4 times (CKD comparison))

Oil impregnated copper bearing at rod bearing dramatically improves abrasion resistance.

## ● Optional piping direction is available

The piping can be selected from 2 way of main body side or main body bottom surface.

### ● MSDG

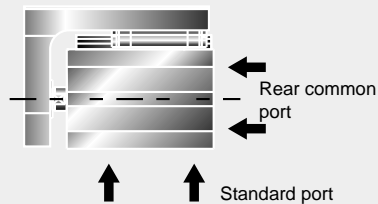

### ● MSD

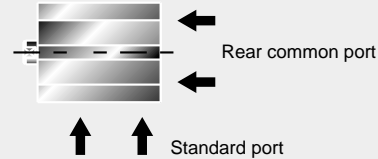

## ● Miniature type with switch F series installation.

6, 8 mm bore compact size with switch is available.

## ● Direct 3-surface mount

Square body enables direct mount on any cylinder surfaces. Through bolts or top installation is possible from top or bottom side. Common rear port enables sideways installations.

High precision, high rigidity and space saving  
High precision guided

# MSDG Series

## ● Axial space saving structure and guided type



High precision guide is installed on short axial length MSD series.  
Meets high precision/high rigidity needs even in narrow space.

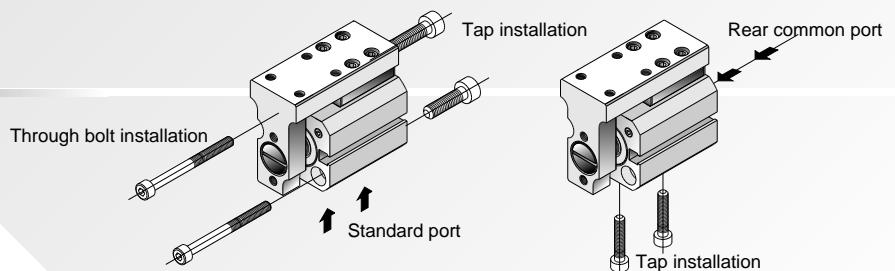
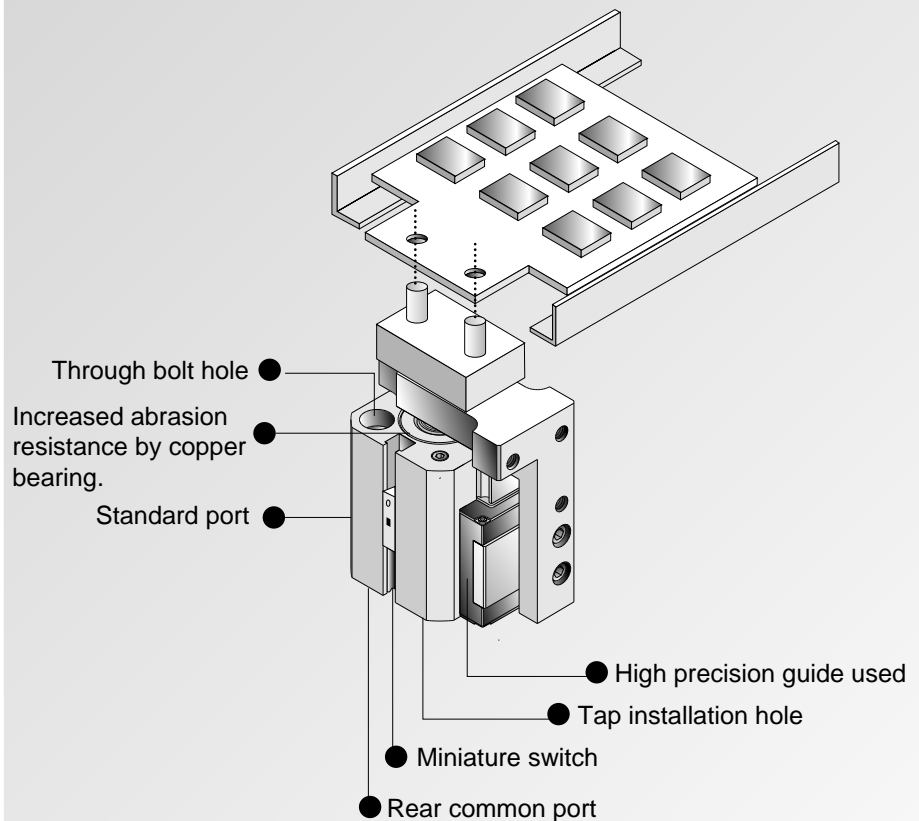

In addition to conventional compact cylinders, 6 and 8 mm bore compact cylinder MSD series is now available. High precision guide is integrated into compact body.

6, 8 mm bore compact cylinder debut.

# MSD Series

● Axial space saving is realized

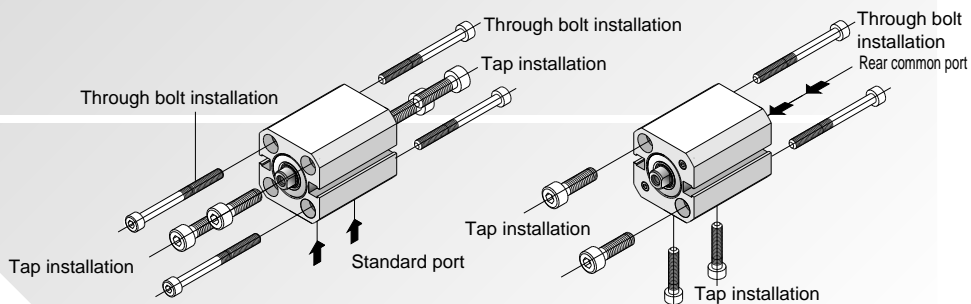
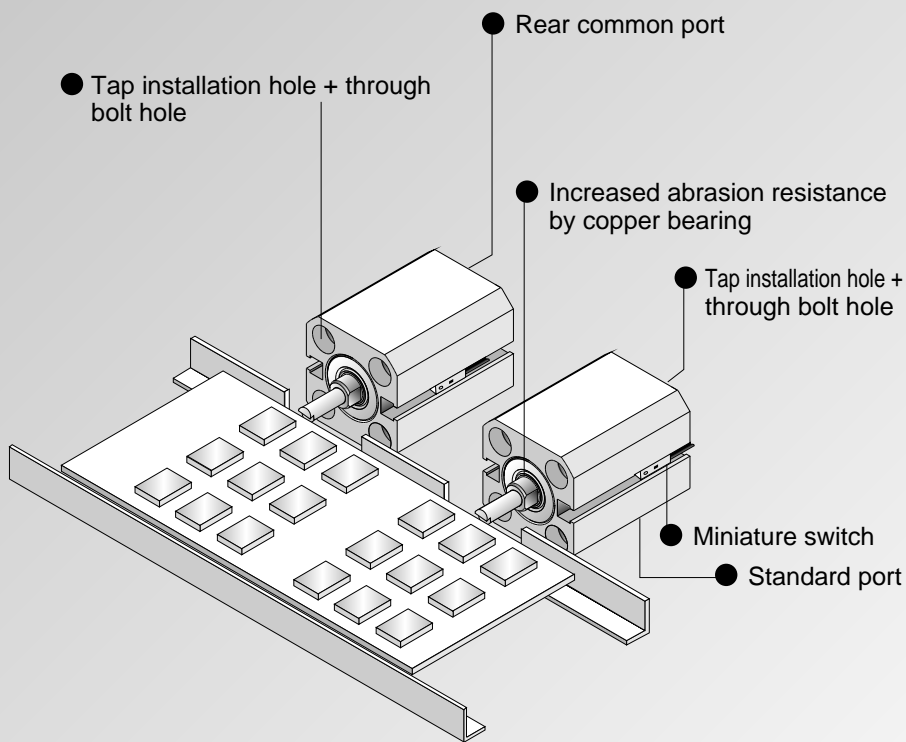
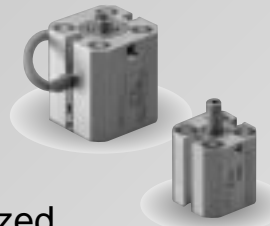



SCP*2
CMK2
CMA2
SCM
SCG
SCA2
SCS
CKV2
CA/OV2
SSD
CAT
MDC2
MVC
SMD2
<b>MSD*</b>
FC*
STK
ULK*
JSK/M2
JSG
JSC3
USSD
USC
JSB3
LMB
STG
STS/L
LCS
LCG
LCM
LCT
LCY
STR2
UCA2
HCM
HCA
SRL2
SRG
SRM
SRT
MRL2
MRG2
SM-25
CAC3
UCAC
RCC2
MFC
SHC
GLC
Ending

Small compact cylinder  
Space saving structure

● : Standard, ◎ : Option, ■ : Not available

SCP\*2  
CMK2  
CMA2  
SCM  
SCG  
SCA2  
SCS  
CKV2  
CA/OV2  
SSD  
CAT  
MDC2  
MVC  
SMD2  
MSD\*  
FC\*  
STK  
ULK\*  
JSK/M2  
JSG  
JSC3  
USSD  
USC  
JSB3  
LMB  
STG  
STS/L  
LCS  
LCG  
LCM  
LCT  
LCY  
STR2  
UCA2  
HCM  
HCA  
SRL2  
SRG  
SRM  
SRT  
MRL2  
MRG2  
SM-25  
CAC3  
UCAC  
RCC2  
MFC  
SHC  
GLC  
Ending

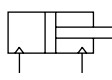
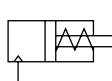
SCP\*2  
CMK2  
CMA2  
SCM  
SCG  
SCA2  
SCS  
CKV2  
CA/OV2  
SSD  
CAT  
MDC2  
MVC  
SMD2  
MSD\*  
FC\*  
STK  
ULK\*  
JSK/M2  
JSG  
JSC3  
USSD  
USC  
JSB3  
LMB  
STG  
STS/L  
LCS  
LCG  
LCM  
LCT  
LCY  
STR2  
UCA2  
HCM  
HCA  
SRL2  
SRG  
SRM  
SRT  
MRL2  
MRG2  
SM-25  
CAC3  
UCAC  
RCC2  
MFC  
SHC  
GLC  
Ending

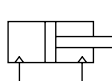
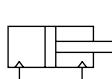
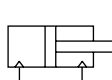
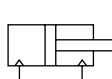
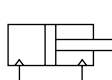
Variation	Model no.	Bore size (mm)	Standard stroke length (mm)						Min. stroke length (mm)	Max. stroke length (mm)	Option	Switch	Page
			5	10	15	20	25	30			Rear common port		
Double acting single rod type with switch	MSD MSD-L 	φ6, φ8	●	●	●	●	●	●	5	30	◎	◎	1048
Single acting extend type with switch	MSD-X MSD-XL 	φ6, φ8	●	●	■	■	■	■	5	10	◎	◎	1056
Single acting retract type with switch	MSD-Y MSD-YL 	φ6, φ8	●	●	■	■	■	■	5	10	◎	◎	1056
Double acting high load type with switch	MSD-K MSD-KL 	φ6, φ8 φ12, φ16	●	●	●	●	●	●	5	30	◎	◎	1066
Double acting single rod type fine speed type with switch	MSD-F MSD-LF 	φ6, φ8	●	●	●	●	●	●	5	30	■	◎	1076
High load type fine speed type with switch	MSD-KF MSD-KLF 	φ6, φ8 φ12, φ16	●	●	●	●	●	●	5	30	◎	◎	1076
Double acting guided	MSDG-L 	φ6, φ8 φ12, φ16	●	●	●	●	●	●	5	30	◎	◎	1078
Double acting guided fine speed type	MSDG-LF 	φ12, φ16	●	●	●	●	●	●	5	30	◎	◎	1088

Small compact cylinder  
Space saving structure

## Major applications

- SCP\*2
- CMK2
- CMA2
- SCM
- SCG
- SCA2
- SCS
- CKV2
- CA/OV2
- SSD
- CAT
- MDC2
- MVC
- SMD2
- MSD\***
- FC\*
- STK
- ULK\*
- JSK/M2
- JSG
- JSC3
- USSD
- USC
- JSB3
- LMB
- STG
- STS/L
- LCS
- LCG
- LCM
- LCT
- LCY
- STR2
- UCA2
- HCM
- HCA
- SRL2
- SRG
- SRM
- SRT
- MRL2
- MRG2
- SM-25
- CAC3
- UCAC
- RCC2
- MFC
- SHC
- GLC
- Ending

**Selection of passed/rejected products**

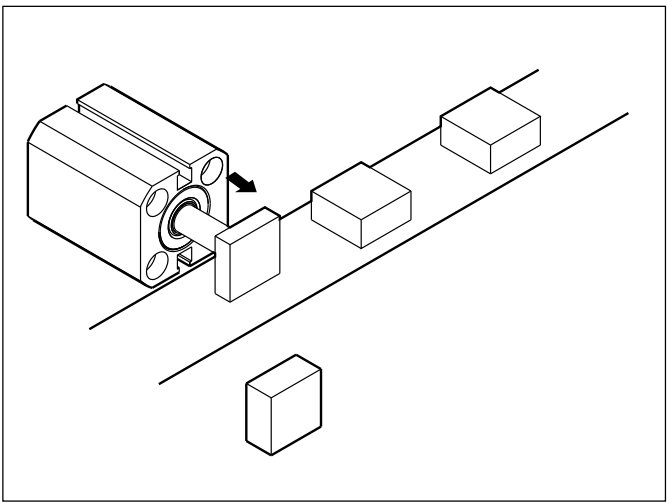

**Clamp**

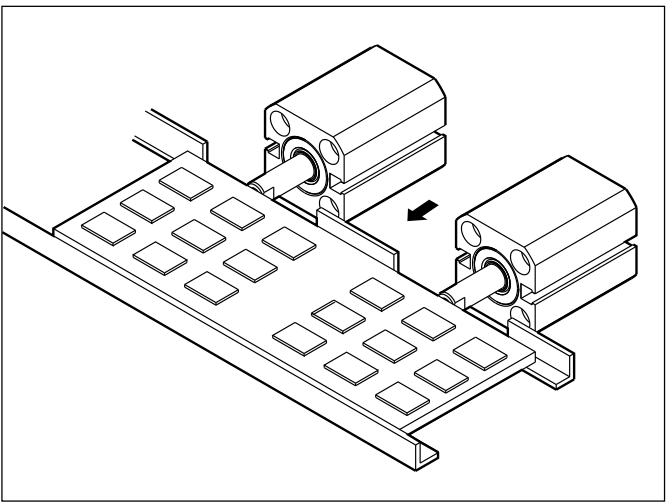

**Positioning of pallet/stopper**

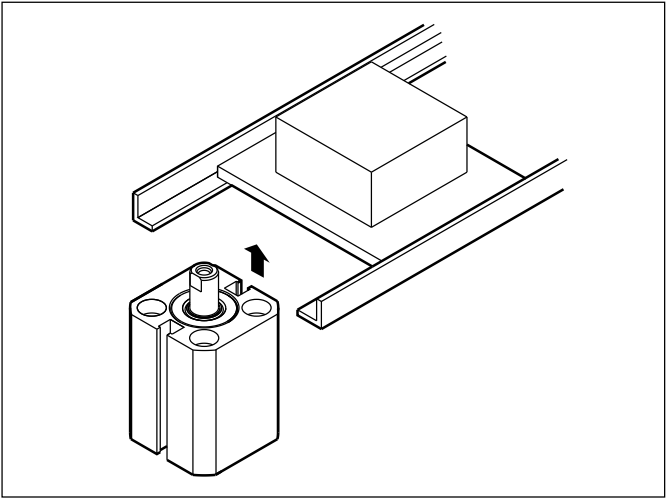

Note: When using as a stopper, consult with CKD.

**Transfer of workpiece**

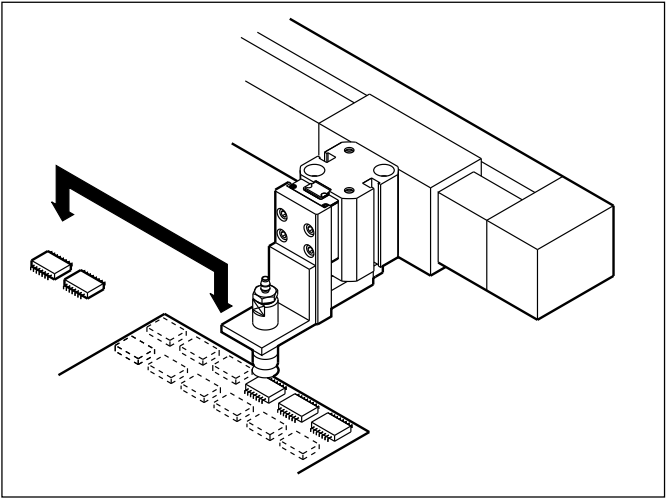

**Pin hole used positioning**

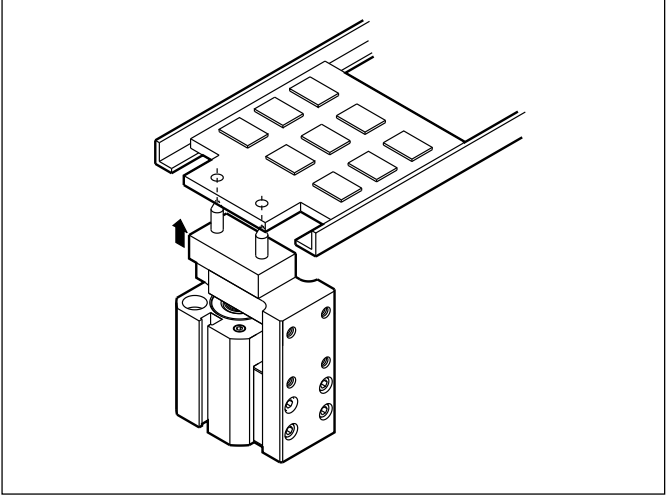

**Compact part feed**

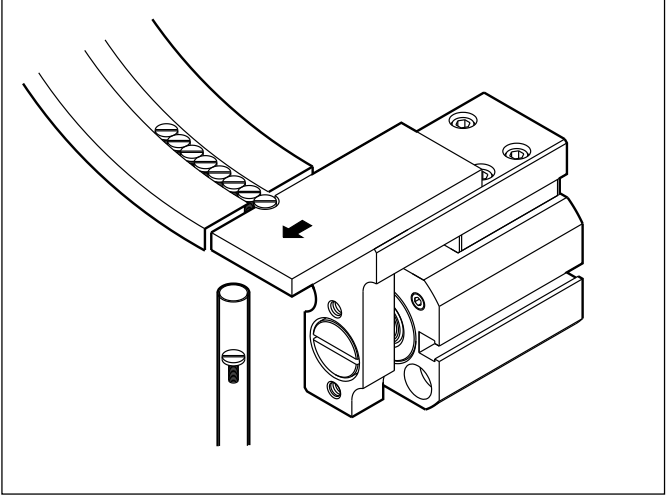

### Variation and option selection table

● MSD Series

- ◎ : Option
- : Available (custom order)
- △ : Available depending on condition (consult CKD)
- X : Not available

Code	Code	Variation						Port thread		Option	
	Symbol	No	K	X	Y	L	F	N	G	R	
Variation	Double acting single rod type	Blank						X	X		◎
	High load type	K		X	X	◎	◎	X	X		◎
	Single acting extend type	X			X	◎	X	X	X		◎
	Single acting retract type	Y				◎	X	X	X		◎
	With cylinder switch	L					◎	X	X		◎
	Fine speed type	F						X	X		◎
Port thread	NPT	N							X		X
	G	G									X
Option	Rear common port	R									
Accessory	Cylinder switch	Listed on Ending	◎	◎	◎	◎	◎	X	X		◎

● Guided type MSDG Series

- ◎ : Option
- : Available (custom order)
- △ : Available depending on condition (consult CKD)
- X : Not available

Code	Code	Variation	Port thread	Option		
	Symbol	No	F	N	G	R
Variation	Double acting single rod type	Blank		X	X	◎
	Fine speed type	F		X	X	◎
Port thread	NPT	N			X	X
	G	G				
Option	Rear common port	R				
Accessory	Cylinder switch	Listed on Ending	◎	◎	X	X

- SCP\*2
- CMK2
- CMA2
- SCM
- SCG
- SCA2
- SCS
- CKV2
- CA/OV2
- SSD
- CAT
- MDC2
- MVC
- SMD2
- MSD\***
- FC\*
- STK
- ULK\*
- JSK/M2
- JSG
- JSC3
- USSD
- USC
- JSB3
- LMB
- STG
- STS/L
- LCS
- LCG
- LCM
- LCT
- LCY
- STR2
- UCA2
- HCM
- HCA
- SRL2
- SRG
- SRM
- SRT
- MRL2
- MRG2
- SM-25
- CAC3
- UCAC
- RCC2
- MFC
- SHC
- GLC

Small compact cylinder  
Space saving structure

SCP*2
CMK2
CMA2
SCM
SCG
SCA2
SCS
CKV2
CA/OV2
SSD
CAT
MDC2
MVC
SMD2
MSD*
FC*
STK
ULK*
JSK/M2
JSG
JSC3
USSD
USC
JSB3
LMB
STG
STS/L
LCS
LCG
LCM
LCT
LCY
STR2
UCA2
HCM
HCA
SRL2
SRG
SRM
SRT
MRL2
MRG2
SM-25
CAC3
UCAC
RCC2
MFC
SHC
GLC
Ending



# Pneumatic components

## Safety precautions

Always read this section before starting use.  
Refer to Intro 71 for general details on the cylinder, and to Intro 78 for details on the cylinder.

### Small compact cylinder MSD/MSDG Series

## Design & Selection

### 1. Common

#### CAUTION

- Follow "Selection guide" on page 1090, when selecting the cylinder.
- When using this cylinder as a stopper, consult with CKD.
- When selecting cylinder switch, refer to "Switch selection table" on page 1059.
- When installation, switch tightening torque should be observed.  
In exceeding tightening torque range, a setscrew, a mounting bracket and a switch etc. may be damaged. While insufficient tightening torque may cause a misallocation of switch.  
Tightening torque: 29.4 (N.mm)

### 2. Single acting MSD-X/Y

#### CAUTION

- Do not use the extending type if a load is applied when the piston rod is retracted, and do not use the retracting type if a load is applied when the position rod is extending.  
The cylindrical spring in the cylinder does not have power to return the piston rod, so if a load is applied, the piston rod will not return to the stroke end.
- This cylinder has a bleed hole which must not be covered when the cylinder is mounted.  
Operation faults could occur if the bleed hole is covered.
- Do not leave the single acting cylinder in the pressurized state.  
If left pressurized, the piston rod may not return with spring power when pressure is released.

### 3. Fine speed type MSD-(K) F/MSDG-LF

#### CAUTION

- Use with oil-free specifications.  
Lubrication may change characteristics.
- Assemble the flow control valve near the cylinder.  
Adjustments become unstable if assembled away from the cylinder. Use the SC-M3/M5, SC3W, SCD-M3/M5, SC3WU Series speed control valve.

- Generally, the higher air pressure, and the smaller load pressure result in the more stable operation.  
Keep the load factor at 50% or less.
- Stable speed control is achieved with a meter-out circuit. When driving the single rod cylinder at fine speed with the operation direction set to PUSH, popping-out may occur if operation is started when load resistance is small. As a countermeasure, use (b), (c), or (d) circuit. Note that the (d) circuit is the most stable.

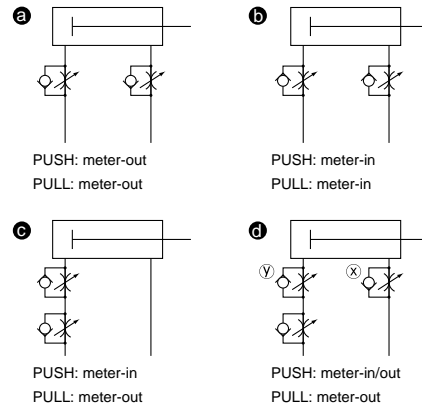

- d** Speed adjustment method at PUSH operation circuit
- Set the speed with the x speed control valve
  - Lower the flow rate with the y speed control valve until popping out no longer occurs
  - Reconfirm of velocity

(Note 1) As comparing (b), (c) and (d), circuit (d) is most stable.

(Note 2) When vertical installation, a meter-in circuit results in falling by its self-weight. So, provide a meter-out circuit.

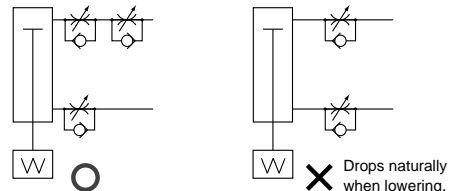

(Note 3) For serial connection of speed control valve, provide a circuit as the following diagram.

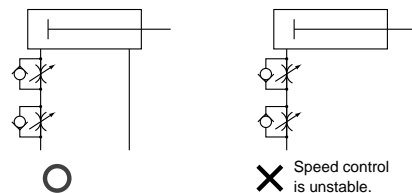

(Cause of popping out)

Reduce the flow rate to reach a fine speed at the exhaust side in a meter-out circuit. This results in the same pressure level on the both sides immediately after valve switched. The thrust caused by the differential of pressurized area of piston is applied to the PUSH direction and a popping-out of piston rod occurs.

(Guide for popping out occurrence)

Popping out occurs when: the piston rod area x air pressure > load resistance.

- Do not apply lateral load a cylinder.  
Install the cylinder to avoid the sliding guide to be twisted.  
The presence of load or resistance variation may result in unstable operations. Operation of a guide having a large difference in stationary and moving friction may become unstable.
- Avoid use with vibration.  
The product will be adversely affected by vibration and operation will be unstable.

## Installation & Adjustment

### 1. Common

#### ⚠ CAUTION

- Piping  
Cautions for piping, speed control and joint  
Applicable piping joints are limited, so refer to the table below.

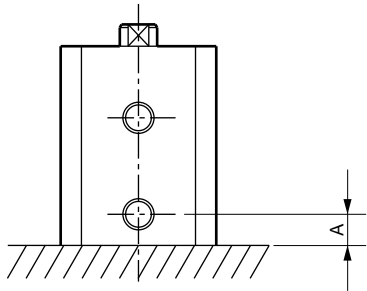

Joint selection table

Symbol Bore size (mm)	Port size	Port dimension A	Applicable speed control valve, joint	Joint O.D.
$\phi 6$ $\phi 8$	M3	4	SC3W-M3-3 SC3W-M3-4 SC3WU-M3-3 SC3WU-M3-4 ----- GWS3-M3-S GWS4-M4-S ----- FTS4-M3	$\phi 8$ or less
$\phi 12$ $\phi 16$	M5	5	SC3W-M5-3 SC3W-M5-4 SC3W-M5-6 SC3WU-M5-3 SC3WU-M5-4 SC3WU-M5-6 ----- GWS4-M5-S GWS6-M5-S ----- FTS4-M5 FTS6-M5	$\phi 10$ or less

- Installation  
Do not damage the main body (cylinder tube) fixing surface and the table surface with dent or scratch etc., which are harmful to flatness. The flatness of object installed onto the table should be 0.05mm or less.

### 2 Fine speed type MSD-K)F/MSDG-LF

#### ⚠ CAUTION

- Adjust the core, etc., so lateral load is not applied to the cylinder.  
Adjust and install so the sliding guide is not twisted.  
The presence of load or resistance variation may result in unstable operations. Operation of a guide having a large difference in stationary and moving friction may become unstable.

SCP*2
CMK2
CMA2
SCM
SCG
SCA2
SCS
CKV2
CA/OV2
SSD
CAT
MDC2
MVC
SMD2
<b>MSD*</b>
FC*
STK
ULK*
JSK/M2
JSG
JSC3
USSD
USC
JSB3
LMB
STG
STS/L
LCS
LCG
LCM
LCT
LCY
STR2
UCA2
HCM
HCA
SRL2
SRG
SRM
SRT
MRL2
MRG2
SM-25
CAC3
UCAC
RCC2
MFC
SHC
GLC
Ending

Small compact cylinder  
Space saving structure



Small compact cylinder, double acting single rod type

# MSD Series

● Bore size:  $\phi 6$ ,  $\phi 8$

JIS symbol

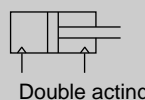

Double acting



## Specifications

Descriptions	MSD MSD-L (with switch)	
Bore size mm	$\phi 6, \phi 8$	
Actuation	Double acting	
Working fluid	Compressed air	
Max. working pressure MPa	1.0	
Min. working pressure MPa	0.15	
Withstanding pressure MPa	1.6	
Ambient temperature $^{\circ}\text{C}$	-10 to 60 (no freezing)	
Port size	M3	
Stroke tolerance mm	+0.5	
	0	
Working piston speed mm/s	50 to 500	
Lubrication	Not required (when lubricating, use turbine oil ISO VG32.)	

## Stroke length

Bore size (mm)	Standard stroke length (mm)	Max. stroke length (mm)	Min. stroke length with 2 switches (mm)		Min. stroke length with 1 switch (mm)	
			Reed switch	Proximity switch	Reed switch	Proximity switch
$\phi 6$	5, 10, 15, 20, 25, 30	30	10	5	5	5
$\phi 8$	5, 10, 15, 20, 25, 30	30	10	5	5	5

Note: Other than standard stroke length is not available.

## Switch specifications

Descriptions	Reed 2 wire	Proximity 2 wire	Proximity 3 wire
	F0H/V	F2H/V	F3H/V
Applications	Programmable controller		Programmable controller, relay
Output method	-		NPN output
Power voltage	-	-	10 to 28 VDC
Load voltage	24 VDC	10 to 30 VDC	30 VDC or less
Load current	5 to 20mA (Note 1)	5 to 20mA (Note 1)	50mA or less
Current consumption	-	-	(When turned ON) 10mA or less with 24 VDC
Internal voltage drop	4V or less		0.5V or less
Light	Yellow LED (ON lighting)		
Leakage current	1mA or less		10 $\mu\text{A}$ or less
Lead wire length (standard)	Standard 1m (oil resistant vinyl cabtire code 2 conductor 0.15mm <sup>2</sup> )		Standard 1m (oil resistant vinyl cabtire code 3 conductor 0.15mm <sup>2</sup> )
Maximum shock resistance	294m/s <sup>2</sup>	980m/s <sup>2</sup>	
Insulation resistance	20 M $\Omega$ and over with 500 VDC megger		
Withstand voltage	No failure at 1000 VAC for one minute.		
Ambient temperature	-10 to + 60 $^{\circ}\text{C}$		
Protective structure	IEC standards IP67, JIS C 0920 (water tight type), oil resistance		

Note 1: Max. load current 20mA is the value at 25  $^{\circ}\text{C}$ .

The current will be lower than 20mA if ambient temperature around switch is higher than 25 $^{\circ}\text{C}$ .  
(5 to 10mA at 60  $^{\circ}\text{C}$ )



- SCP\*2
- CMK2
- CMA2
- SCM
- SCG
- SCA2
- SCS
- CKV2
- CA/OV2
- SSD
- CAT
- MDC2
- MVC
- SMD2
- MSD\***
- FC\*
- STK
- ULK\*
- JSK/M2
- JSG
- JSC3
- USSD
- USC
- JSB3
- LMB
- STG
- STS/L
- LCS
- LCG
- LCM
- LCT
- LCY
- STR2
- UCA2
- HCM
- HCA
- SRL2
- SRG
- SRM
- SRT
- MRL2
- MRG2
- SM-25
- CAC3
- UCAC
- RCC2
- MFC
- SHC
- GLC
- Ending

Small compact cylinder  
Space saving structure

Cylinder weight table

Stroke length (mm)	5		10		15		20		25		30		Weight per 1 switch (g)
Bore size (mm)	W/o switch	With switch	W/o switch	With switch	W/o switch	With switch	W/o switch	With switch	W/o switch	With switch	W/o switch	With switch	
φ6	22	24	25	27	27	29	30	32	33	35	36	38	10
φ8	23	26	28	31	33	36	38	41	42	45	47	50	

- SCP\*2
- CMK2
- CMA2
- SCM
- SCG
- SCA2
- SCS
- CKV2
- CA/OV2
- SSD
- CAT
- MDC2
- MVC
- SMD2
- MSD\***
- FC\*
- STK
- ULK\*
- JSK/M2
- JSG
- JSC3
- USSD
- USC
- JSB3
- LMB
- STG
- STS/L
- LCS
- LCG
- LCM
- LCT
- LCY
- STR2
- UCA2
- HCM
- HCA
- SRL2
- SRG
- SRM
- SRT
- MRL2
- MRG2
- SM-25
- CAC3
- UCAC
- RCC2
- MFC
- SHC
- GLC
- Ending

## How to order

● Without switch

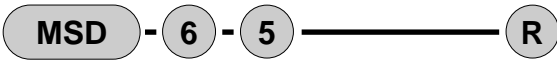

● With switch

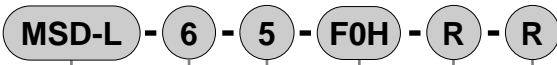

**A** Model no.

**B** Bore size

**C** Stroke length

**D** Switch model no.

Note 1

**E** Switch quantity

**F** Piping port position

Note 2

Symbol	Descriptions			
<b>A Model no.</b>				
MSD	Double acting			Without switch
MSD-L	single rod type			With switch
<b>B Bore size (mm)</b>				
6	φ6			
8	φ8			
<b>C Stroke length (mm)</b>				
5	5			
10	10			
15	15			
20	20			
25	25			
30	30			
<b>D Switch model no.</b>				
Axial lead wire	Radial lead wire	Contact	Indicator	Lead wire
F0H*	F0V*	Reed	1 color indicator type	2-wire
F2H*	F2V*	Proximity		3-wire
F3H*	F3V*			
<b>*Lead wire length</b>				
Blank	1m (standard)			
3	3m (option)			
<b>E Switch quantity</b>				
R	1 on rod end			
H	1 on head end			
D	Two			
<b>F Piping port position</b>				
Blank	Body side surface port			
R	Rear common port			

## Note on model no. selection

Note 1: For 6, 8 mm bore cylinders with switches, use mounting bolts that do not contain magnetic substances (stainless steel etc.).

Note 2: For rear common port type, a side installation is possible. In this case, two bolts are used for head or rod side installation.

## <Example of model number>

### MSD-L-6-5-F0H-R-R

- A** Model no. : Double acting single rod type with switch
- B** Bore size : φ6mm
- C** Stroke length : 5mm
- D** Switch model no. : Reed F0H, lead wire 1m
- E** Switch quantity : 1 on rod end
- F** Option : Rear common port

## How to order switch

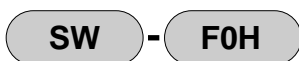

Switch model no.  
(Item **D** above)

### Switch selection table

Switches could not be installed depending on relations between cylinder installation and stroke length. Refer to the table below to select a switch.

All switches can be used when side installation. (Refer to page 1048 for min. stroke length with switch)

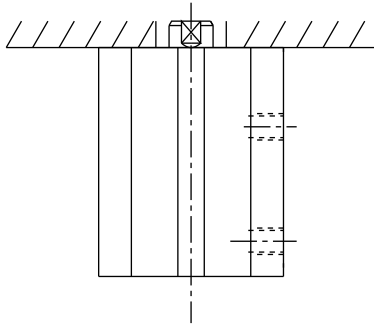

(R) Rod end installation

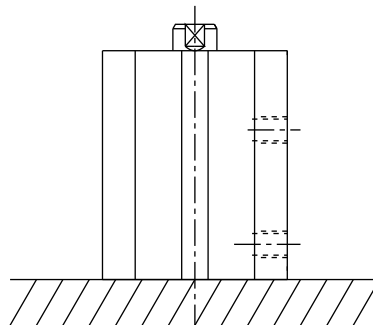

(H) Head end installation

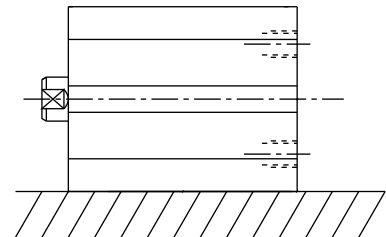

Side installation

#### ● Rod end installation

Bore size (mm)	Stroke length (mm)	Reed switch				Proximity switch			
		F0H		F0V		F2H/F3H		F2V/F3V	
		Switch installation position		Switch installation position		Switch installation position		Switch installation position	
		R	H	R	H	R	H	R	H
φ6	5	○	○	○	○	○	X	○	○
	10	○	○	○	○	○	○	○	○
	15 to	○	○	○	○	○	○	○	○
φ8	5	○	○	○	○	○	X	○	○
	10	○	○	○	○	○	○	○	○
	15 to	○	○	○	○	○	○	○	○

#### ● Head end installation

Bore size (mm)	Stroke length (mm)	Reed switch				Proximity switch			
		F0H		F0V		F2H/F3H		F2V/F3V	
		Switch installation position		Switch installation position		Switch installation position		Switch installation position	
		R	H	R	H	R	H	R	H
φ6	5	X	X	○	○	X	○	○	○
	10	○	X	○	○	X	○	○	○
	15 to	○	X	○	○	○	○	○	○
φ8	5	X	X	○	○	X	○	○	○
	10	○	X	○	○	X	○	○	○
	15 to	○	X	○	○	○	○	○	○

- SCP\*2
- CMK2
- CMA2
- SCM
- SCG
- SCA2
- SCS
- CKV2
- CA/OV2
- SSD
- CAT
- MDC2
- MVC
- SMD2
- MSD\***
- FC\*
- STK
- ULK\*
- JSK/M2
- JSG
- JSC3
- USSD
- USC
- JSB3
- LMB
- STG
- STS/L
- LCS
- LCG
- LCM
- LCT
- LCY
- STR2
- UCA2
- HCM
- HCA
- SRL2
- SRG
- SRM
- SRT
- MRL2
- MRG2
- SM-25
- CAC3
- UCAC
- RCC2
- MFC
- SHC
- GLC
- Ending

Small compact cylinder  
Space saving structure

## Internal structure and parts list

SCP*2
CMK2
CMA2
SCM
SCG
SCA2
SCS
CKV2
CA/OV2
SSD
CAT
MDC2
MVC
SMD2
<b>MSD*</b>
FC*
STK
ULK*
JSK/M2
JSG
JSC3
USSD
USC
JSB3
LMB
STG
STS/L
LCS
LCG
LCM
LCT
LCY
STR2
UCA2
HCM
HCA
SRL2
SRG
SRM
SRT
MRL2
MRG2
SM-25
CAC3
UCAC
RCC2
MFC
SHC
GLC
Ending

● MSD-6, 8

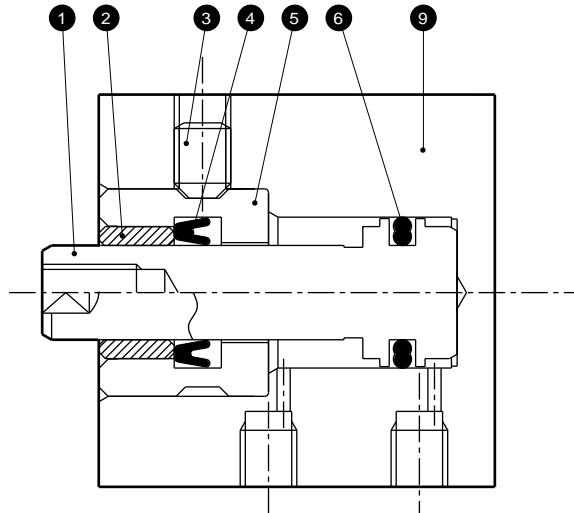

● MSD-L-6, 8

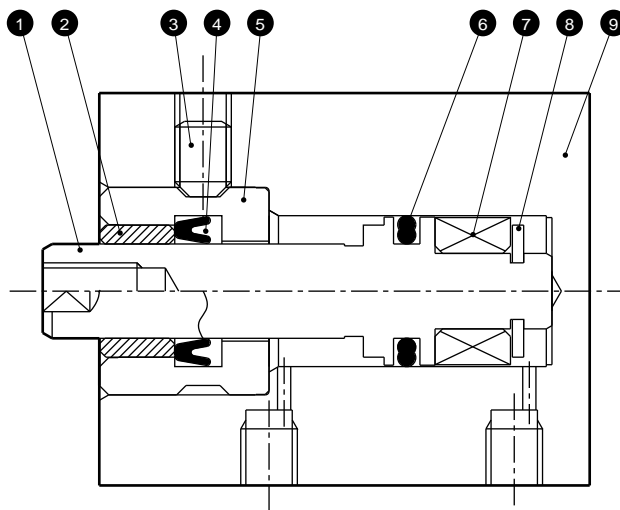

No.	Parts name	Material	Remarks	No.	Parts name	Material	Remarks
1	Piston	Stainless steel		6	Piston packing seal	Nitrile rubber	
2	Bush	Oil impregnated copper alloy		7	Magnet	Plastic	
3	Hexagon socket head set screw	Stainless steel		8	E type snap ring	Stainless steel	
4	Rod packing seal	Nitrile rubber		9	Body	Aluminum alloy	Hard alumite
5	Rod bushing	Stainless steel					

### Dimensions



● MSD- (L)-6, 8

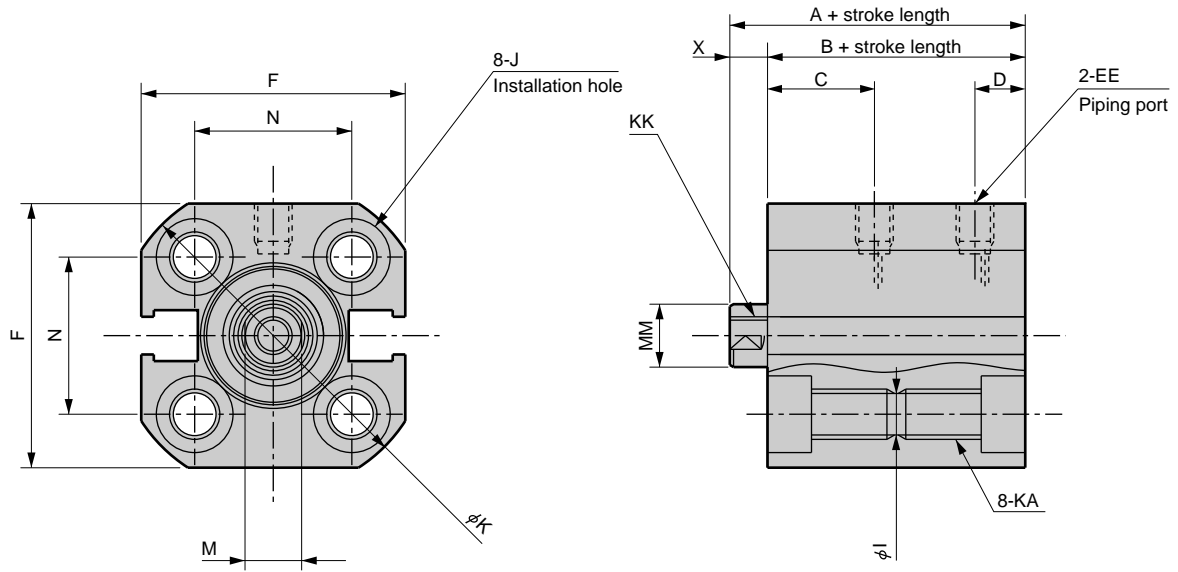

● MSD- (L)-6, 8-\*R (rear common port)

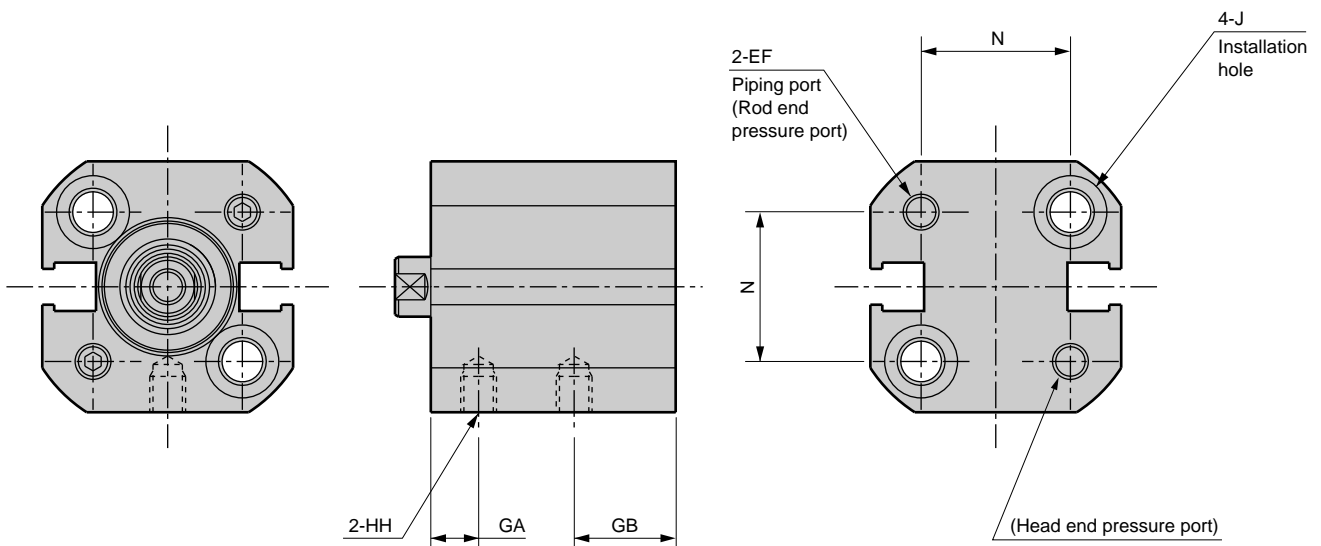

- SCP\*2
- CMK2
- CMA2
- SCM
- SCG
- SCA2
- SCS
- CKV2
- CA/OV2
- SSD
- CAT
- MDC2
- MVC
- SMD2
- MSD\***
- FC\*
- STK
- ULK\*
- JSK/M2
- JSG
- JSC3
- USSD
- USC
- JSB3
- LMB
- STG
- STS/L
- LCS
- LCG
- LCM
- LCT
- LCY
- STR2
- UCA2
- HCM
- HCA
- SRL2
- SRG
- SRM
- SRT
- MRL2
- MRG2
- SM-25
- CAC3
- UCAC
- RCC2
- MFC
- SHC
- GLC

Ending

Small compact cylinder  
Space saving structure

Bore size (mm)	Without switch		With switch		Without switch/common dimension with switch											
	A	B	A	B	C	D	EE	EF	F	GA	GB	HH	I	J	K	KA
φ6	17.5	14.5	22.5	19.5	7.5	4	M3	M3	19	3	8.5	M3 depth 3	3.2	Spot face φ6.1 depth 3.5	22.5	M4 depth 6
φ8	19	16	24	21	9	4	M3	M3	21	4.5	8.5	M3 depth 3	3.2	Spot face φ6.1 depth 3.5	25	M4 depth 6

Bore size (mm)	Without switch/common part with switch				
	KK	M	MM	N	X
φ6	M2.5 depth 4	3.5	4	11	3
φ8	M3 depth 5	4.5	5	12.5	3

## Switch installation position

### ● Switch installation position

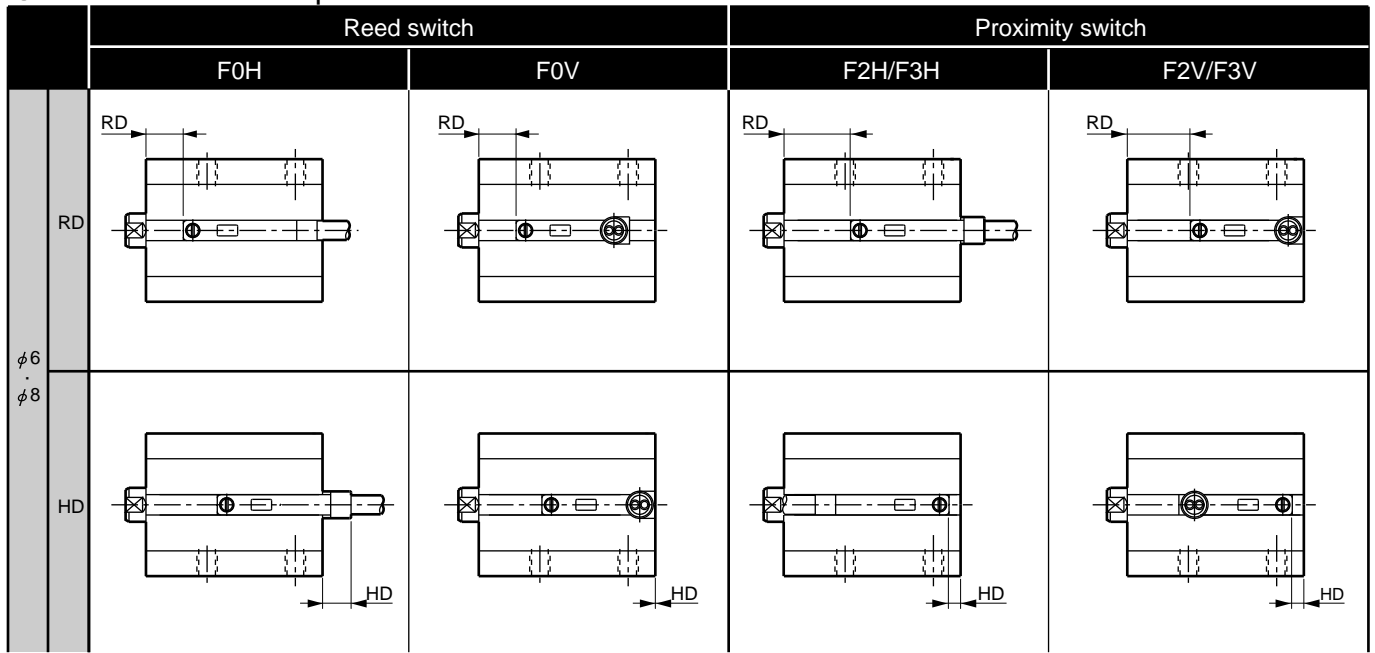

### ● Switch installation position dimension

(mm)

Model	Bore size (mm)	Reed switch				Proximity switch			
		F0H		F0V		F2H/F3H		F2V/F3V	
		RD	HD	RD	HD	RD	HD	RD	HD
MSD-L	φ6	3.5	3.5	3.5	0.0	7.5	1.5	7.5	1.5
	φ8	5.5	4.0	5.5	0.0	9.5	1.0	9.5	1.0



Small compact cylinder, single acting extend type/with switch  
single acting retract type/with switch

# MSD-X Series

● Bore size:  $\phi 6$ ,  $\phi 8$

JIS symbol



Single acting extend type    Single acting retract type



## Specifications

Descriptions	MSD-X MSD-XL (with switch)		MSD-Y MSD-YL (with switch)	
	$\phi 6$	$\phi 8$	$\phi 6$	$\phi 8$
Bore size    mm	$\phi 6$	$\phi 8$	$\phi 6$	$\phi 8$
Actuation	Single acting extend type		Single acting retract type	
Working fluid	Compressed air			
Max. working pressure    MPa	1.0			
Min. working pressure    MPa	0.3		0.4	0.3
Withstanding pressure    MPa	1.6			
Ambient temperature    °C	-10 to 60 (no freezing)			
Port size	M3			
Stroke tolerance    mm	+0.5			
	0			
Working piston speed    mm/s	50 to 500			
Lubrication	Not required (when lubricating, use turbine oil ISO VG32.)			

## Stroke length

Bore size (mm)	Standard stroke length (mm)	Max. stroke length (mm)	Min. stroke length with 2 switches (mm)		Min. stroke length with 1 switch (mm)	
			Reed switch	Proximity switch	Reed switch	Proximity switch
$\phi 6$	5, 10	10	10	5	5	5
$\phi 8$	5, 10	10	10	5	5	5

Note: Other than standard stroke length is not available.

## Switch specifications

Descriptions	Reed 2 wire	Proximity 2 wire	Proximity 3 wire
	F0H/V	F2H/V	F3H/V
Applications	Programmable controller		Programmable controller, relay
Output method	-		NPN output
Power voltage	-	-	10 to 28 VDC
Load voltage	24 VDC	10 to 30 VDC	30 VDC or less
Load current	5 to 20mA (Note 1)	5 to 20mA (Note 1)	50mA or less
Current consumption	-	-	(When turned ON) 10mA or less with 24 VDC
Internal voltage drop	4V or less		0.5V or less
Light	Yellow LED (ON lighting)		
Leakage current	1mA or less		10 $\mu$ A or less
Lead wire length (standard)	Standard 1m (oil resistant vinyl cabtire code 2 conductor 0.15mm <sup>2</sup> )		Standard 1m (oil resistant vinyl cabtire code 3 conductor 0.15mm <sup>2</sup> )
Maximum shock resistance	294m/s <sup>2</sup>	980m/s <sup>2</sup>	
Insulation resistance	20M $\Omega$ and over with 500 VDC megger		
Withstand voltage	No failure at 1000 VAC for one minute.		
Ambient temperature	-10 to + 60°C		
Protective structure	IEC standards IP67, JIS C 0920 (water tight type), oil resistance		

Note 1: Max. load current 29mA is the value at 25°C.

The current will be lower than 20mA if ambient temperature around switch is higher than 20mA.  
(5 to 10mA at 60°C)

## Cylinder weight table

### ● MSD-X/MSD-XL (g)

Stroke length (mm)	5		10		Weight per 1 switch
	W/o switch	With switch	W/o switch	With switch	
φ6	23	25	28	30	10
φ8	24	27	33	36	

### ● MSD-Y/MSD-YL (g)

Stroke length (mm)	5		10		Weight per 1 switch
	W/o switch	With switch	W/o switch	With switch	
φ6	25	27	31	33	10
φ8	28	31	38	41	

## MSD-X/Y spring load (N)

Bore size (mm)	Stroke length (mm)	Spring load	
		When setting	Operation
φ6	5	1.59	4.90
	10		
φ8	5	3.19	6.86
	10		

SCP*2
CMK2
CMA2
SCM
SCG
SCA2
SCS
CKV2
CA/OV2
SSD
CAT
MDC2
MVC
SMD2
<b>MSD*</b>
FC*
STK
ULK*
JSK/M2
JSG
JSC3
USSD
USC
JSB3
LMB
STG
STS/L
LCS
LCG
LCM
LCT
LCY
STR2
UCA2
HCM
HCA
SRL2
SRG
SRM
SRT
MRL2
MRG2
SM-25
CAC3
UCAC
RCC2
MFC
SHC
GLC
Ending

Small compact cylinder  
Space saving structure



- SCP\*2
- CMK2
- CMA2
- SCM
- SCG
- SCA2
- SCS
- CKV2
- CA/OV2
- SSD
- CAT
- MDC2
- MVC
- SMD2
- MSD\***
- FC\*
- STK
- ULK\*
- JSK/M2
- JSG
- JSC3
- USSD
- USC
- JSB3
- LMB
- STG
- STS/L
- LCS
- LCG
- LCM
- LCT
- LCY
- STR2
- UCA2
- HCM
- HCA
- SRL2
- SRG
- SRM
- SRT
- MRL2
- MRG2
- SM-25
- CAC3
- UCAC
- RCC2
- MFC
- SHC
- GLC
- Ending

## How to order

● Without switch

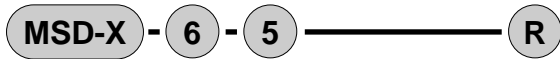

● With switch

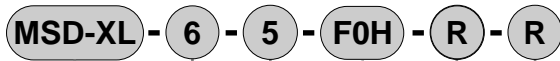

**A** Model no.

--	--	--	--	--	--

**B** Bore size

--	--	--	--	--	--

**C** Stroke length

--	--	--	--	--	--

**D** Switch model no.  
Note 1

--	--	--	--	--	--

**E** Switch quantity

--	--	--	--	--	--

**F** Piping port position  
Note 2

--	--	--	--	--	--

### ⚠ Note on model no. selection

Note 1: For 6, 8 mm bore cylinders with switches, use mounting bolts that do not contain magnetic substances (stainless steel etc.).

Note 2: For rear common port type, a side installation is possible. In this case, two bolts are used for head or rod side installation.

### <Example of model number>

#### MSD-XL-6-5-F0H-R-R

- A** Model no. : Single acting extend type with switch
- B** Bore size :  $\phi$  6mm
- C** Stroke length : 5mm
- D** Switch model no. : Reed F0H, lead wire 1m
- E** Switch quantity : 1 on rod end
- F** Option : Rear common port

Symbol	Descriptions			
<b>A Model no.</b>				
<b>MSD-X</b>	Single acting extend type	Without switch		
<b>MSD-Y</b>	Single acting retract type			
<b>MSD-XL</b>	Single acting extend type	With switch		
<b>MSD-YL</b>	Single acting retract type			
<b>B Bore size (mm)</b>				
<b>6</b>	$\phi$ 6			
<b>8</b>	$\phi$ 8			
<b>C Stroke length (mm)</b>				
<b>5</b>	5			
<b>10</b>	10			
<b>D Switch model no.</b>				
Axial lead wire	Radial lead wire	Contact	Indicator	Lead wire
<b>F0H*</b>	<b>F0V*</b>	Reed	1 color indicator type	2-wire
<b>F2H*</b>	<b>F2V*</b>			
<b>F3H*</b>	<b>F3V*</b>			
<b>*Lead wire length</b>				
<b>Blank</b>	1m (standard)			
<b>3</b>	3m (option)			
<b>E Switch quantity</b>				
<b>R</b>	1 on rod end			
<b>H</b>	1 on head end			
<b>D</b>	Two			
<b>F Piping port position</b>				
<b>Blank</b>	Body side surface port			
<b>R</b>	Rear common port			

## How to order switch

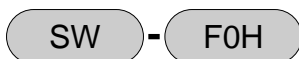

Switch model no.  
(Item **D** above)

### Switch selection table

Switches could not be installed depending on relations between cylinder installation and stroke length. Refer to the table below to select a switch.

All switches can be used when side installation. (Refer to page 1056 for min. stroke length with switch)

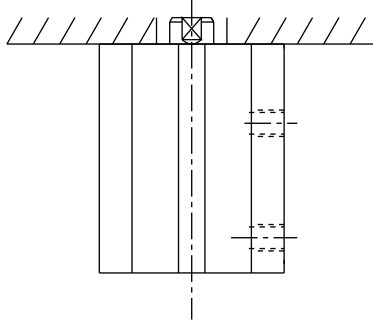

(R) Rod end installation

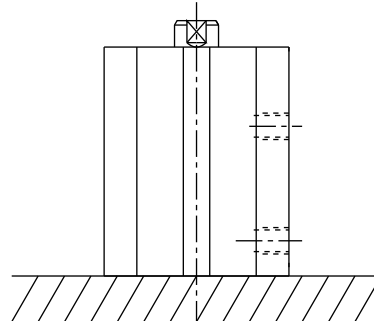

(H) Head end installation

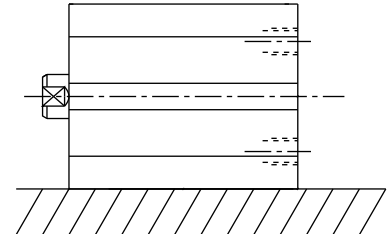

Side installation

#### ● MSD-XL Rod end installation

Bore size (mm)	Stroke length (mm)	Reed switch				Proximity switch			
		F0H		F0V		F2H/F3H		F2V/F3V	
		Switch installation position		Switch installation position		Switch installation position		Switch installation position	
		R	H	R	H	R	H	R	H
φ6	5	○	○	○	○	○	X	○	○
	10	○	○	○	○	○	○	○	○
φ8	5	○	○	○	○	○	X	○	○
	10	○	○	○	○	○	○	○	○

#### ● MSD-XL Head end installation

Bore size (mm)	Stroke length (mm)	Reed switch				Proximity switch			
		F0H		F0V		F2H/F3H		F2V/F3V	
		Switch installation position		Switch installation position		Switch installation position		Switch installation position	
		R	H	R	H	R	H	R	H
φ6	5	X	X	○	○	X	○	○	○
	10	○	X	○	○	X	○	○	○
φ8	5	X	X	○	○	X	○	○	○
	10	○	X	○	○	X	○	○	○

#### ● MSD-YL Rod end installation

Bore size (mm)	Stroke length (mm)	Reed switch				Proximity switch			
		F0H		F0V		F2H/F3H		F2V/F3V	
		Switch installation position		Switch installation position		Switch installation position		Switch installation position	
		R	H	R	H	R	H	R	H
φ6	5	○	○	○	○	○	X	○	○
	10	○	○	○	○	○	○	○	○
φ8	5	○	○	○	○	○	X	○	○
	10	○	○	○	○	○	○	○	○

#### ● MSD-YL Head end installation

Bore size (mm)	Stroke length (mm)	Reed switch				Proximity switch			
		F0H		F0V		F2H/F3H		F2V/F3V	
		Switch installation position		Switch installation position		Switch installation position		Switch installation position	
		R	H	R	H	R	H	R	H
φ6	5	○	○	○	○	X	○	○	○
	10	○	○	○	○	○	○	○	○
φ8	5	○	○	○	○	X	○	○	○
	10	○	○	○	○	○	○	○	○

- SCP\*2
- CMK2
- CMA2
- SCM
- SCG
- SCA2
- SCS
- CKV2
- CA/OV2
- SSD
- CAT
- MDC2
- MVC
- SMD2
- MSD\***
- FC\*
- STK
- ULK\*
- JSK/M2
- JSG
- JSC3
- USSD
- USC
- JSB3
- LMB
- STG
- STS/L
- LCS
- LCG
- LCM
- LCT
- LCY
- STR2
- UCA2
- HCM
- HCA
- SRL2
- SRG
- SRM
- SRT
- MRL2
- MRG2
- SM-25
- CAC3
- UCAC
- RCC2
- MFC
- SHC
- GLC

Ending

Small compact cylinder  
Space saving structure

## Internal structure and parts list

SCP*2
CMK2
CMA2
SCM
SCG
SCA2
SCS
CKV2
CA/OV2
SSD
CAT
MDC2
MVC
SMD2
<b>MSD*</b>
FC*
STK
ULK*
JSK/M2
JSG
JSC3
USSD
USC
JSB3
LMB
STG
STS/L
LCS
LCG
LCM
LCT
LCY
STR2
UCA2
HCM
HCA
SRL2
SRG
SRM
SRT
MRL2
MRG2
SM-25
CAC3
UCAC
RCC2
MFC
SHC
GLC
Ending

● MSD-X-6, 8

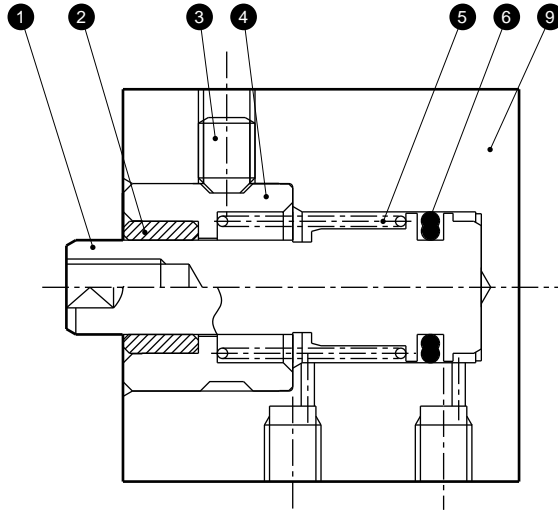

● MSD-XL-6, 8

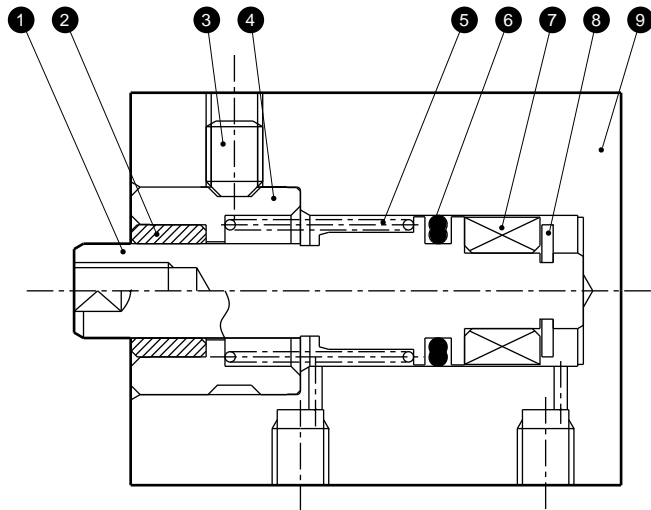

No.	Parts name	Material	Remarks	No.	Parts name	Material	Remarks
1	Piston	Stainless steel		6	Piston packing seal	Nitrile rubber	
2	Bush	Oil impregnated copper alloy		7	Magnet	Plastic	
3	Hexagon socket head set screw	Stainless steel		8	E type snap ring	Stainless steel	
4	Rod bushing	Stainless steel		9	Body	Aluminum alloy	Hard alumite
5	Coil spring	Steel	Electrode position coating				

### Internal structure and parts list

● MSD-Y-6, 8

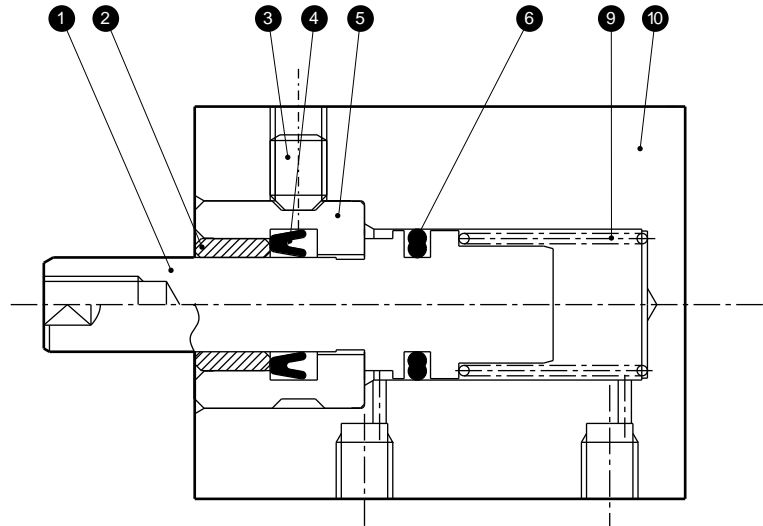

● MSD-YL-6, 8

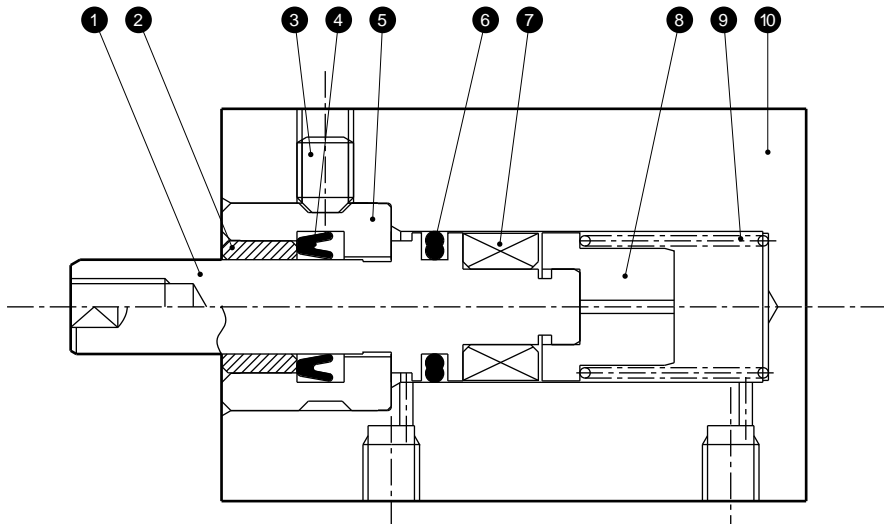

SCP*2
CMK2
CMA2
SCM
SCG
SCA2
SCS
CKV2
CA/OV2
SSD
CAT
MDC2
MVC
SMD2
<b>MSD*</b>
FC*
STK
ULK*
JSK/M2
JSG
JSC3
USSD
USC
JSB3
LMB
STG
STS/L
LCS
LCG
LCM
LCT
LCY
STR2
UCA2
HCM
HCA
SRL2
SRG
SRM
SRT
MRL2
MRG2
SM-25
CAC3
UCAC
RCC2
MFC
SHC
GLC
Ending

Small compact cylinder  
Space saving structure

No.	Parts name	Material	Remarks	No.	Parts name	Material	Remarks
1	Piston	Stainless steel		6	Piston packing seal	Nitrile rubber	
2	Bush	Oil impregnated copper alloy		7	Magnet	Plastic	
3	Hexagon socket head set screw	Stainless steel		8	Spring holder	Stainless steel	
4	Rod packing seal	Nitrile rubber		9	Coil spring	Steel	Electrode position coating
5	Rod bushing	Stainless steel		10	Body	Aluminum alloy	Hard alumite

## Dimensions



- SCP\*2
- CMK2
- CMA2
- SCM
- SCG
- SCA2
- SCS
- CKV2
- CA/OV2
- SSD
- CAT
- MDC2
- MVC
- SMD2
- MSD\***
- FC\*
- STK
- ULK\*
- JSK/M2
- JSG
- JSC3
- USSD
- USC
- JSB3
- LMB
- STG
- STS/L
- LCS
- LCG
- LCM
- LCT
- LCY
- STR2
- UCA2
- HCM
- HCA
- SRL2
- SRG
- SRM
- SRT
- MRL2
- MRG2
- SM-25
- CAC3
- UCAC
- RCC2
- MFC
- SHC
- GLC
- Ending

### ● MSD-X (L)-6, 8

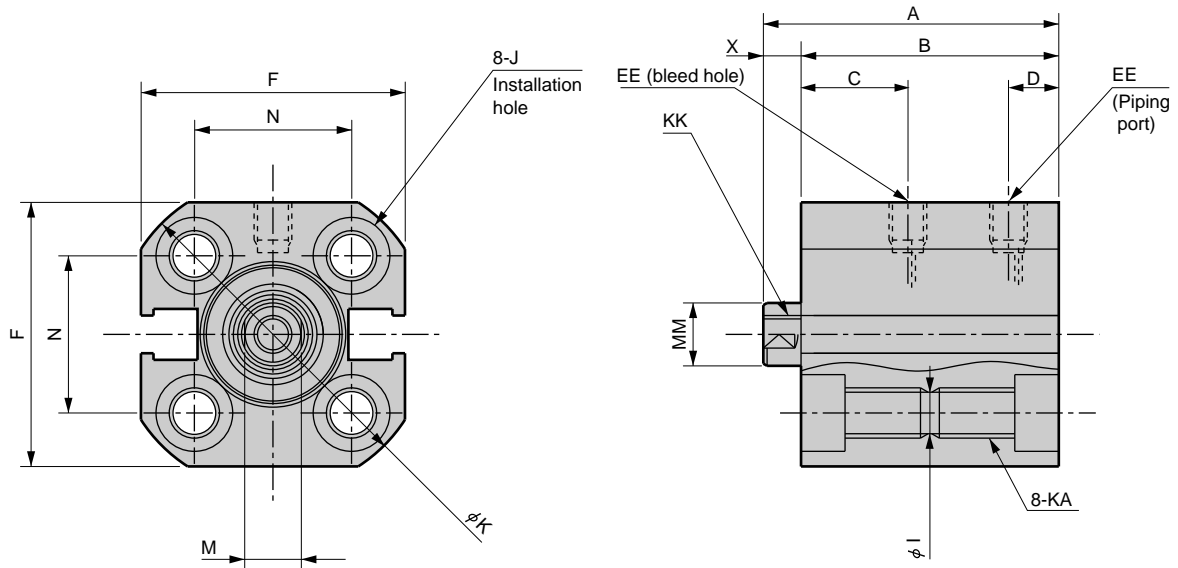

### ● MSD-X (L)-6, 8\*-R (rear common port)

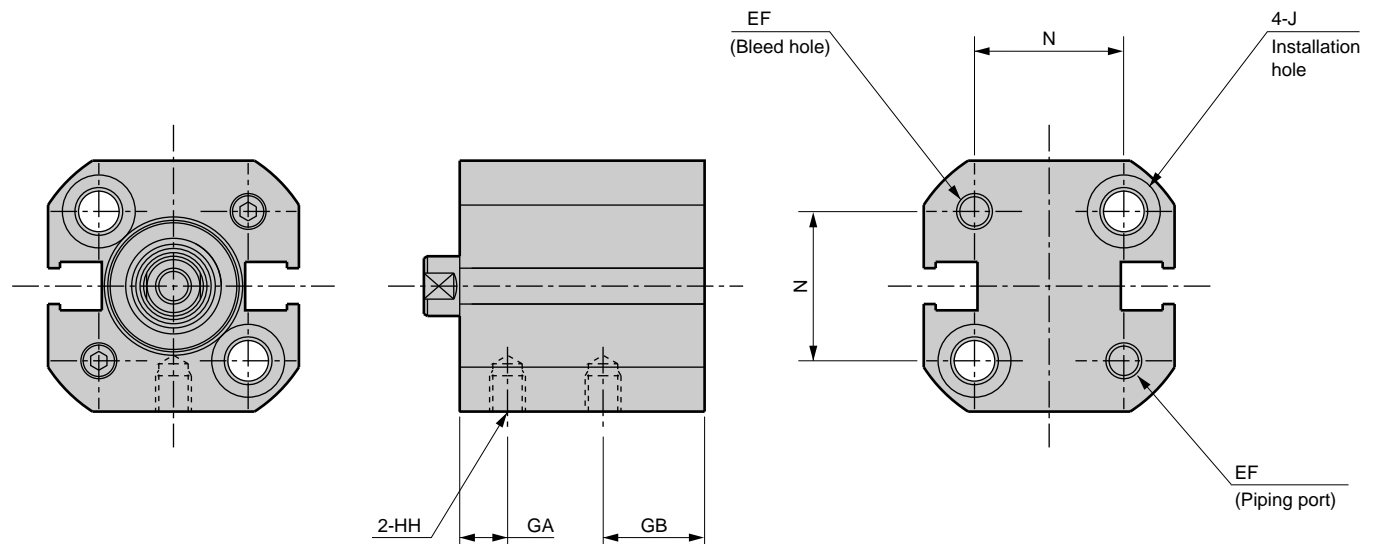

Symbol	Without switch		With switch		Without switch/common dimension with switch																	
	Bore size (mm)	A	B	A	B	C	D	EE	EF	F	GA	GB	HH	I	J	K	KA	KK	M	MM	N	X
φ6	Stroke length 5	22.5	19.5	27.5	24.5	7.5	4	M3	M3	19	3	8.5	M3 depth 3	3.2	Spot face φ8.1 depth 3.5	22.5	M4 depth 6	M2.5 depth 4	3.5	4	11	3
	Stroke length 10	32.5	29.5	37.5	34.5																	
φ8	Stroke length 5	24	21	29	26	9	4	M3	M3	21	4.5	8.5	M3 depth 3	3.2	Spot face φ6.1 depth 3.5	25	M4 depth 6	M3 depth 5	4.5	5	12.5	3
	Stroke length 10	34	31	39	36																	

### Dimensions



#### ● MSD-Y (L)-6, 8

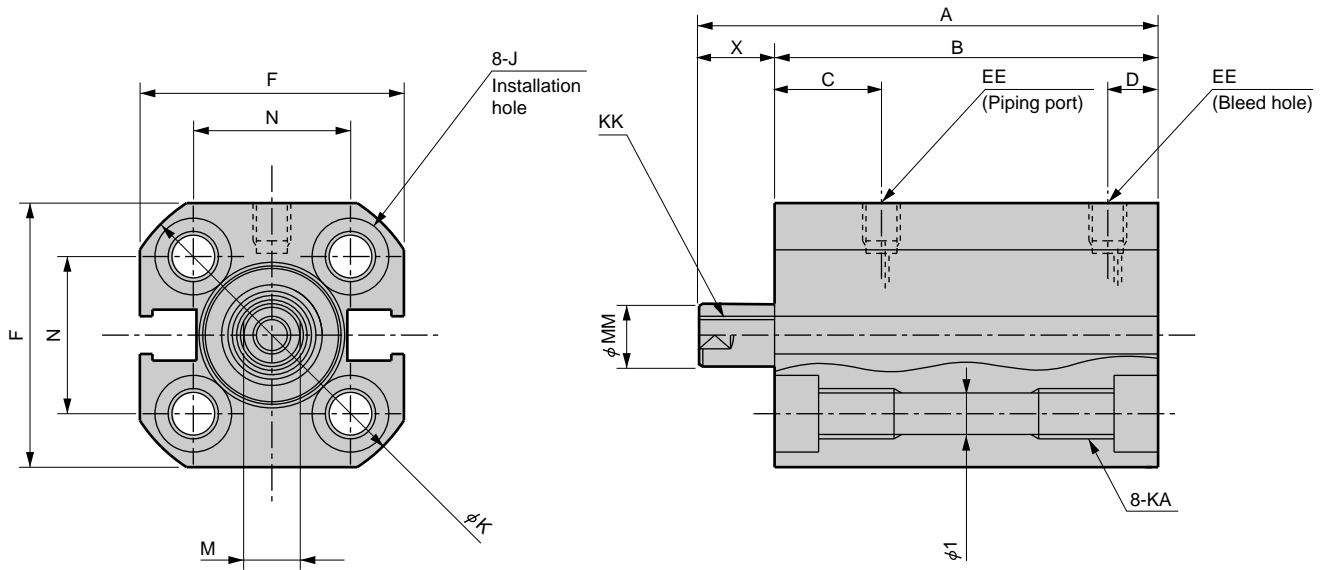

#### ● MSD-Y (L)-6, 8-\*-R (rear common port)

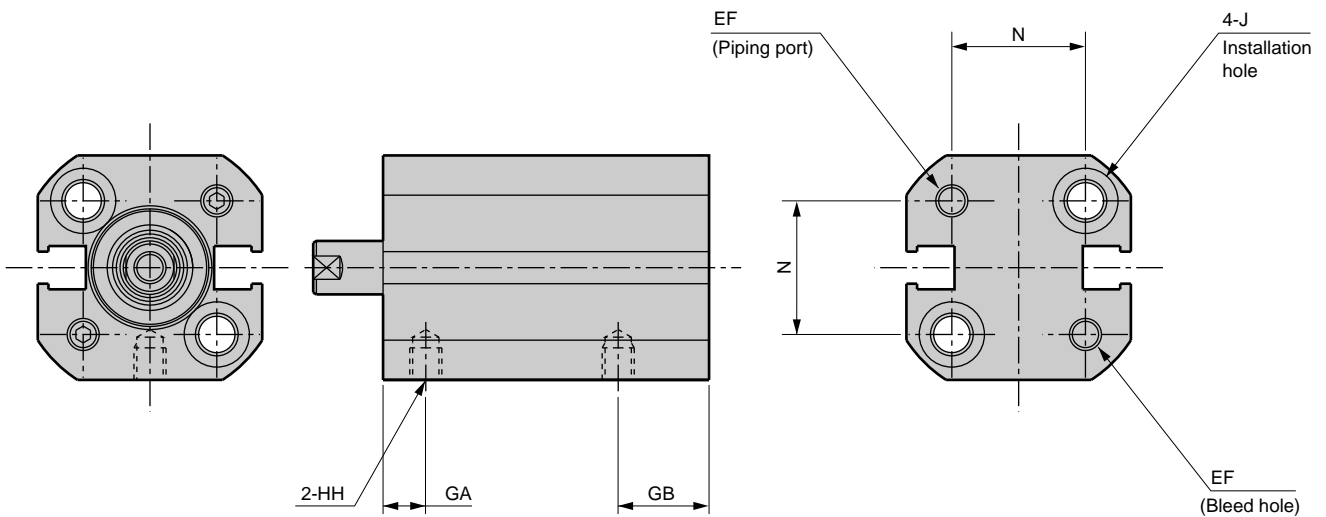

Symbol	Without switch		With switch		Without switch/common dimension with switch																	
	A	B	A	B	C	D	EE	EF	F	GA	GB	HH	I	J	K	KA	KK	M	MM	N	X	
φ6	Stroke length 5	32.5	24.5	37.5	29.5	7.5	4	M3	M3	19	3	8.5	M3 depth 3	3.2	Spot face φ6.1 depth 3.5	22.5	M4 depth 6	M2.5 depth 4	3.5	4	11	8
	Stroke length 10	47.5	34.5	52.5	39.5																	13
φ8	Stroke length 5	34	26	39	31	9	4	M3	M3	21	4.5	8.5	M3 depth 3	3.2	Spot face φ6.1 depth 3.5	25	M4 depth 6	M3 depth 5	4.5	5	12.5	8
	Stroke length 10	49	36	54	41																	13

- SCP\*2
- CMK2
- CMA2
- SCM
- SCG
- SCA2
- SCS
- CKV2
- CA/OV2
- SSD
- CAT
- MDC2
- MVC
- SMD2
- MSD\***
- FC\*
- STK
- ULK\*
- JSK/M2
- JSG
- JSC3
- USSD
- USC
- JSB3
- LMB
- STG
- STS/L
- LCS
- LCG
- LCM
- LCT
- LCY
- STR2
- UCA2
- HCM
- HCA
- SRL2
- SRG
- SRM
- SRT
- MRL2
- MRG2
- SM-25
- CAC3
- UCAC
- RCC2
- MFC
- SHC
- GLC

Ending

Small compact cylinder  
Space saving structure

## Switch installation position

### ● MSD-XL switch installation position

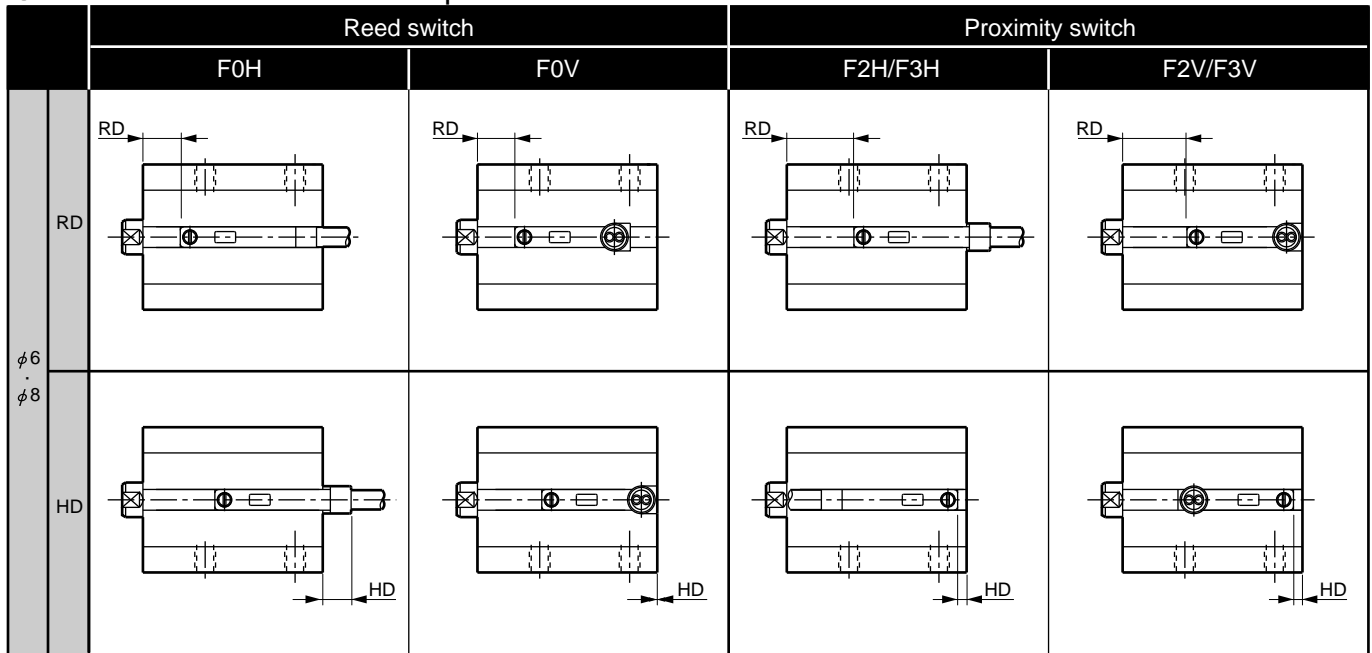

### ● Switch installation position dimension

(mm)

Switch	Switch model no.	Max. sensitive position	Stroke length	Reed switch				Proximity switch			
				F0H		F0V		F2H/F3H		F2V/F3V	
				RD	HD	RD	HD	RD	HD	RD	HD
MSD-XL	φ6	5	4.0	4.0	4.0	0	7.5	1.5	7.5	1.5	
		10	9.0	4.0	9.0	0	12.5	1.5	12.5	1.5	
	φ8	5	5.5	4.0	5.5	0	9.0	1.5	9.0	1.5	
		10	10.5	4.0	10.5	0	14.0	1.5	14.0	1.5	

### Switch installation position

#### ● MSD-YL switch installation position

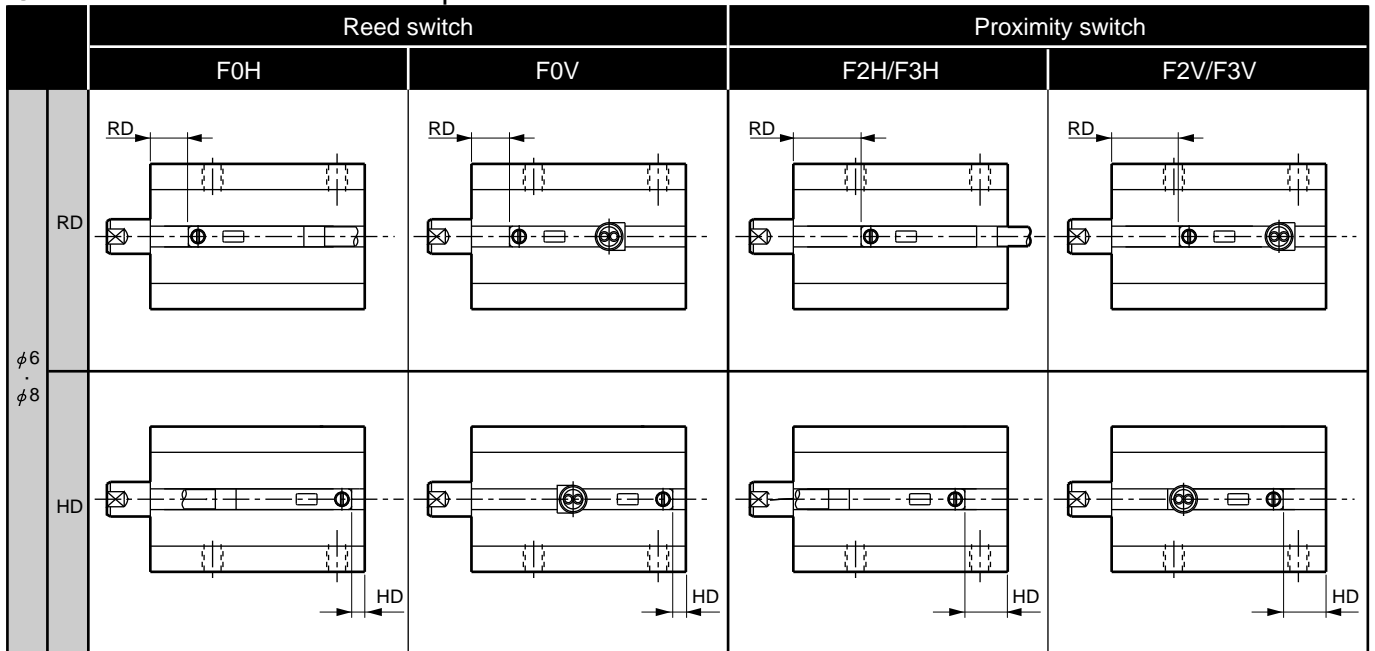

#### ● Switch installation position dimension

		Reed switch				Proximity switch				(mm)
Bore size	Stroke length	Switch model no.	F0H		F0V		F2H/F3H		F2V/F3V	
			RD	HD	RD	HD	RD	HD	RD	HD
MSD-YL	φ6	5	3.5	2.5	3.5	2.5	8.0	7.0	8.0	7.0
		10	3.5	7.5	3.5	7.5	8.0	12.0	8.0	12.0
	φ8	5	5.5	2.0	5.5	2.0	10.0	6.0	10.0	6.0
		10	5.5	7.0	5.5	7.0	10.0	11.0	10.0	11.0

- SCP\*2
- CMK2
- CMA2
- SCM
- SCG
- SCA2
- SCS
- CKV2
- CA/OV2
- SSD
- CAT
- MDC2
- MVC
- SMD2
- MSD\***
- FC\*
- STK
- ULK\*
- JSK/M2
- JSG
- JSC3
- USSD
- USC
- JSB3
- LMB
- STG
- STS/L
- LCS
- LCG
- LCM
- LCT
- LCY
- STR2
- UCA2
- HCM
- HCA
- SRL2
- SRG
- SRM
- SRT
- MRL2
- MRG2
- SM-25
- CAC3
- UCAC
- RCC2
- MFC
- SHC
- GLC

Ending

Small compact cylinder  
Space saving structure





Small compact cylinder, double acting high load type

# MSD-K Series

● Bore size:  $\phi 6$ ,  $\phi 8$ ,  $\phi 12$ ,  $\phi 16$

JIS symbol



Double acting



## Specifications

Descriptions		MSD-K MSD-KL (with switch)			
		$\phi 6$	$\phi 8$	$\phi 12$	$\phi 16$
Bore size	mm	$\phi 6$	$\phi 8$	$\phi 12$	$\phi 16$
Actuation		Double acting			
Working fluid		Compressed air			
Max. working pressure	MPa	1.0			
Min. working pressure	MPa	0.15		0.1	
Withstanding pressure	MPa	1.6			
Ambient temperature	°C	-10 to 60 (no freezing)			
Connection	Body side surface port	M3		M5	
	Rear common port	M3		M3	
Stroke tolerance	mm	+2.0			
		0			
Working piston speed	mm/s	50 to 500			
Lubrication		Not required (when lubricating, use turbine oil ISO VG32.)			

## Stroke length

Bore size (mm)	Standard stroke length (mm)	Max. stroke length (mm)	Min. stroke length with 2 switches (mm)		Min. stroke length with 1 switch (mm)	
			Reed switch	Proximity switch	Reed switch	Proximity switch
$\phi 6$	5, 10, 15, 20, 25, 30	30	10	5	5	5
$\phi 8$	5, 10, 15, 20, 25, 30	30	10	5	5	5
$\phi 12$	5, 10, 15, 20, 25, 30	30	10	5	5	5
$\phi 16$	5, 10, 15, 20, 25, 30	30	10	5	5	5

Note: Other than standard stroke length is not available.

## Switch specifications

Descriptions	Reed 2 wire	Proximity 2 wire	Proximity 3 wire
	F0H/V	F2H/V	F3H/V
Applications	Programmable controller		Programmable controller, relay
Output method	-		NPN output
Power voltage	-	-	10 to 28 VDC
Load voltage	24 VDC	10 to 30 VDC	30 VDC or less
Load current	5 to 20mA (Note 1)	5 to 20mA (Note 1)	50mA or less
Current consumption	-	-	(When turned ON) 10mA or less with 24 VDC
Internal voltage drop	4V or less		0.5V or less
Light	Yellow LED (ON lighting)		
Leakage current	1mA or less		10 $\mu$ A or less
Lead wire length (standard)	Standard 1m (oil resistant vinyl cabtire code 2 conductor 0.15mm <sup>2</sup> )		Standard 1m (oil resistant vinyl cabtire code 3 conductor 0.15mm <sup>2</sup> )
Maximum shock resistance	294m/s <sup>2</sup>	980m/s <sup>2</sup>	
Insulation resistance	20M $\Omega$ and over with 500 VDC megger		
Withstand voltage	No failure at 1000 VAC for one minute.		
Ambient temperature	-10 to + 60°C		
Protective structure	IEC standards IP67, JIS C 0920 (water tight type), oil resistance		

Note 1:Max. load current 29mA is the value at 25°C.

The current will be lower than 20mA if ambient temperature around switch is higher than 20mA.  
(5 to 10mA at 60°C )

Cylinder weight table

Stroke length (mm)	5		10		15		20		25		30		Weight per 1 switch
Bore size (mm)	W/o switch	With switch	W/o switch	With switch	W/o switch	With switch	W/o switch	With switch	W/o switch	With switch	W/o switch	With switch	
φ6	27	29	30	32	32	34	35	37	38	40	41	43	10
φ8	29	32	34	37	39	42	44	47	48	51	53	56	
φ12	35	45	43	53	52	62	61	71	70	80	79	89	
φ16	54	70	66	82	79	95	92	108	104	120	117	133	

(g)

- SCP\*2
- CMK2
- CMA2
- SCM
- SCG
- SCA2
- SCS
- CKV2
- CA/OV2
- SSD
- CAT
- MDC2
- MVC
- SMD2
- MSD\*
- FC\*
- STK
- ULK\*
- JSK/M2
- JSG
- JSC3
- USSD
- USC
- JSB3
- LMB
- STG
- STS/L
- LCS
- LCG
- LCM
- LCT
- LCY
- STR2
- UCA2
- HCM
- HCA
- SRL2
- SRG
- SRM
- SRT
- MRL2
- MRG2
- SM-25
- CAC3
- UCAC
- RCC2
- MFC
- SHC
- GLC
- Ending

Small compact cylinder  
Space saving structure

## How to order

● Without switch

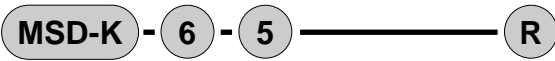

● With switch

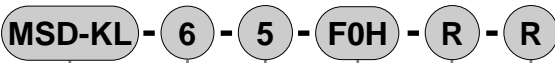

**A** Model no.

**B** Bore size

**C** Stroke length

**D** Switch model no.

Note 1  
Note 2

**E** Switch quantity

**F** Piping port position  
Note 3



### Cautions on model no. selection

Note 1: For 6, 8 mm bore cylinders with reed switches, use mounting bolts that do not contain magnetic substances (stainless steel etc.).

Note 2: For 6, 8 mm bore cylinders with proximity switches, use mounting bolts that do not contain magnetic substances (stainless steel etc.).  
For 12, 16 mm bore cylinders, if used with through bolts, use mounting bolts that do not contain magnetic substances (stainless steel etc.).

Note 3: For rear common port type, a side installation is possible. In this case, two bolts are used for head or rod side installation.

### <Example of model number>

#### MSD-KL-6-5-F0H-R-R

- A** Model no. : Double acting high load with switch
- B** Bore size :  $\phi$  6mm
- C** Stroke length : 5mm
- D** Switch model no. : Reed F0H
- E** Switch quantity : 1 on rod end
- F** Option : Rear common port

## How to order switch

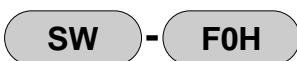

Switch model no.  
(Item **D** above)

Symbol	Descriptions	
<b>A</b> Model no.		
MSD-K	Double acting high load type	Without switch
MSD-KL		With switch

<b>B</b> Bore size (mm)	
6	$\phi$ 6
8	$\phi$ 8
12	$\phi$ 12
16	$\phi$ 16

<b>C</b> Stroke length (mm)	
5	5
10	10
15	15
20	20
25	25
30	30

<b>D</b> Switch model no.				
Axial lead wire	Radial lead wire	Contact	Indicator	Lead wire
F0H*	F0V*	Reed	1 color indicator type	2-wire
F2H*	F2V*			
F3H*	F3V*	Proximity		3-wire

<b>*Lead wire length</b>	
Blank	1m (standard)
3	3m (option)

<b>E</b> Switch quantity	
R	1 on rod end
H	1 on head end
D	Two

<b>F</b> Piping port position	
Blank	Body side surface port
R	Rear common port

### Switch selection table

Switches could not be installed depending on relations between cylinder installation and stroke length. Refer to the table below to select a switch.

All switches can be used when side installation. (Refer to page 1066 for min. stroke length with switch)

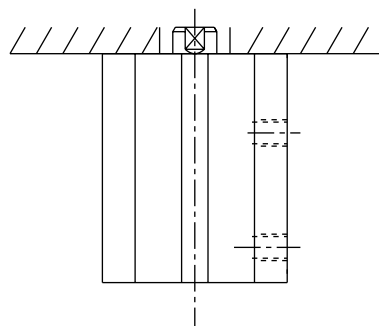

(R) Rod end installation

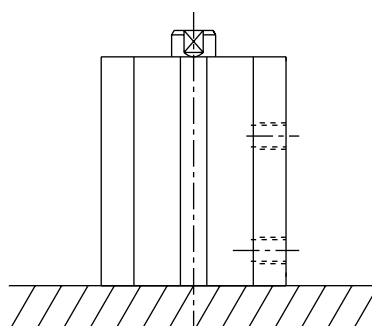

(H) Head end installation

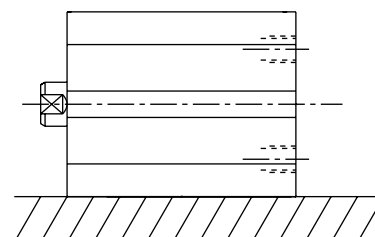

Side installation

#### ● Rod end installation

Bore size (mm)	Stroke length (mm)	Reed switch				Proximity switch			
		F0H		F0V		F2H/F3H		F2V/F3V	
		Switch installation position		Switch installation position		Switch installation position		Switch installation position	
		R	H	R	H	R	H	R	H
φ6	5	○	○	○	○	○	○	○	○
	10	○	○	○	○	○	○	○	○
	15 to	○	○	○	○	○	X	○	○
φ8	5	○	○	○	○	○	○	○	○
	10	○	○	○	○	○	○	○	○
	15 to	○	○	○	○	○	X	○	○
φ12	5	○	○	○	○	○	○	○	○
	10	○	○	○	○	○	○	○	○
	15 to	○	○	○	○	○	X	○	○
φ16	5	○	○	○	○	○	○	○	○
	10	○	○	○	○	○	○	○	○
	15 to	○	○	○	○	○	X	○	○

#### ● Head end installation

Bore size (mm)	Stroke length (mm)	Reed switch				Proximity switch			
		F0H		F0V		F2H/F3H		F2V/F3V	
		Switch installation position		Switch installation position		Switch installation position		Switch installation position	
		R	H	R	H	R	H	R	H
φ6	5	X	○	○	○	X	○	○	○
	10	○	○	○	○	X	○	○	○
	15 to	○	○	○	○	○	○	○	○
φ8	5	X	○	○	○	X	○	○	○
	10	○	○	○	○	X	○	○	○
	15 to	○	○	○	○	○	○	○	○
φ12	5	X	○	○	○	X	○	○	○
	10	○	○	○	○	X	○	○	○
	15 to	○	○	○	○	○	○	○	○
φ16	5	X	○	○	○	X	○	○	○
	10	○	○	○	○	X	○	○	○
	15 to	○	○	○	○	○	○	○	○

- SCP\*2
- CMK2
- CMA2
- SCM
- SCG
- SCA2
- SCS
- CKV2
- CA/OV2
- SSD
- CAT
- MDC2
- MVC
- SMD2
- MSD\*
- FC\*
- STK
- ULK\*
- JSK/M2
- JSG
- JSC3
- USSD
- USC
- JSB3
- LMB
- STG
- STS/L
- LCS
- LCG
- LCM
- LCT
- LCY
- STR2
- UCA2
- HCM
- HCA
- SRL2
- SRG
- SRM
- SRT
- MRL2
- MRG2
- SM-25
- CAC3
- UCAC
- RCC2
- MFC
- SHC
- GLC

Ending

Small compact cylinder  
Space saving structure

## Internal structure and parts list

SCP*2
CMK2
CMA2
SCM
SCG
SCA2
SCS
CKV2
CA/OV2
SSD
CAT
MDC2
MVC
SMD2
<b>MSD*</b>
FC*
STK
ULK*
JSK/M2
JSG
JSC3
USSD
USC
JSB3
LMB
STG
STS/L
LCS
LCG
LCM
LCT
LCY
STR2
UCA2
HCM
HCA
SRL2
SRG
SRM
SRT
MRL2
MRG2
SM-25
CAC3
UCAC
RCC2
MFC
SHC
GLC
Ending

●MSD-K-6, 8, 12

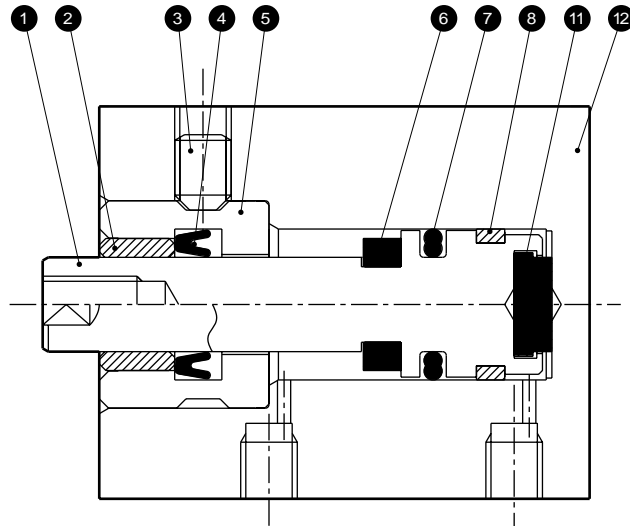

●MSD-KL-6, 8, 12

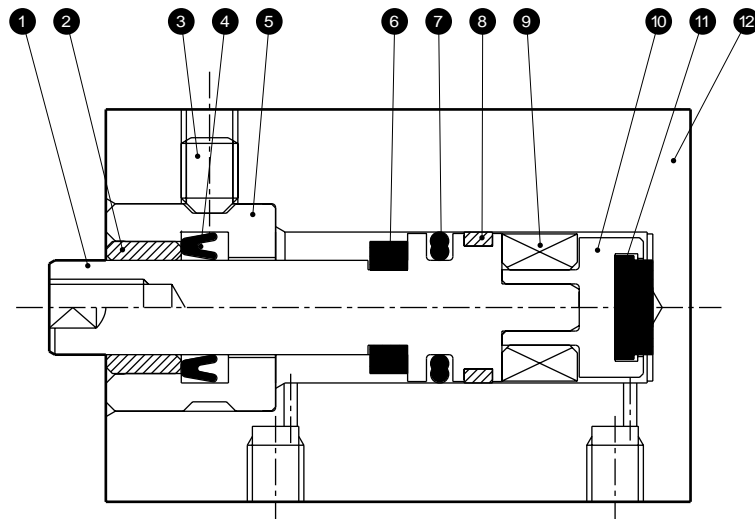

No.	Parts name	Material	Remarks	No.	Parts name	Material	Remarks
1	Piston	Stainless steel		7	Piston packing seal	Nitrile rubber	
2	Bush	Oil impregnated copper alloy		8	Wear ring	Acetar resin	
3	Hexagon socket head set screw	Stainless steel		9	Magnet	Plastic	
4	Rod packing seal	Nitrile rubber		10	Adaptor	Aluminum alloy	
5	Rod bushing	Stainless steel		11	Cushion rubber H	Urethane rubber	
6	Cushion rubber R	Urethane rubber		12	Body	Aluminum alloy	Hard alumite

### Internal structure and parts list

● MSD-K-16

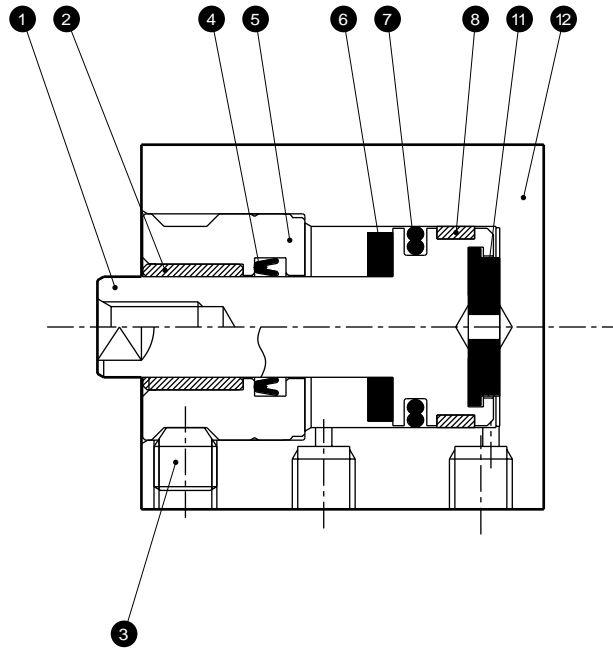

● MSD-KL-16

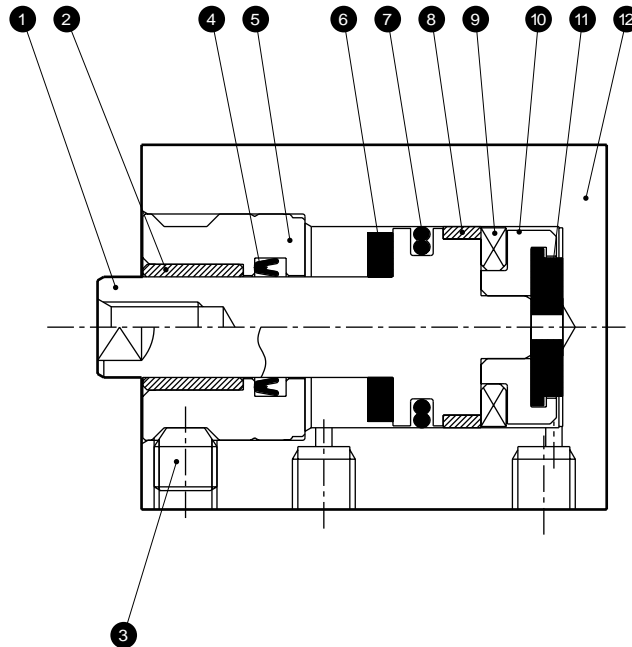

SCP*2
CMK2
CMA2
SCM
SCG
SCA2
SCS
CKV2
CA/OV2
SSD
CAT
MDC2
MVC
SMD2
<b>MSD*</b>
FC*
STK
ULK*
JSK/M2
JSG
JSC3
USSD
USC
JSB3
LMB
STG
STS/L
LCS
LCG
LCM
LCT
LCY
STR2
UCA2
HCM
HCA
SRL2
SRG
SRM
SRT
MRL2
MRG2
SM-25
CAC3
UCAC
RCC2
MFC
SHC
GLC

Ending

Small compact cylinder  
Space saving structure

No.	Parts name	Material	Remarks	No.	Parts name	Material	Remarks
1	Piston	Stainless steel		7	Piston packing seal	Nitrile rubber	
2	Bush	Oil impregnated copper alloy		8	Wear ring	Acetar resin	
3	Hexagon socket head set screw	Stainless steel		9	Magnet	Plastic	
4	Rod packing seal	Nitrile rubber		10	Adaptor	Aluminum alloy	
5	Rod bushing	Stainless steel		11	Cushion rubber H	Urethane rubber	
6	Cushion rubber R	Urethane rubber		12	Body	Aluminum alloy	Hard alumite

## Dimensions



- SCP\*2
- CMK2
- CMA2
- SCM
- SCG
- SCA2
- SCS
- CKV2
- CA/OV2
- SSD
- CAT
- MDC2
- MVC
- SMD2
- MSD\***
- FC\*
- STK
- ULK\*
- JSK/M2
- JSG
- JSC3
- USSD
- USC
- JSB3
- LMB
- STG
- STS/L
- LCS
- LCG
- LCM
- LCT
- LCY
- STR2
- UCA2
- HCM
- HCA
- SRL2
- SRG
- SRM
- SRT
- MRL2
- MRG2
- SM-25
- CAC3
- UCAC
- RCC2
- MFC
- SHC
- GLC
- Ending

### ● MSD-K (L)-6, 8, 12

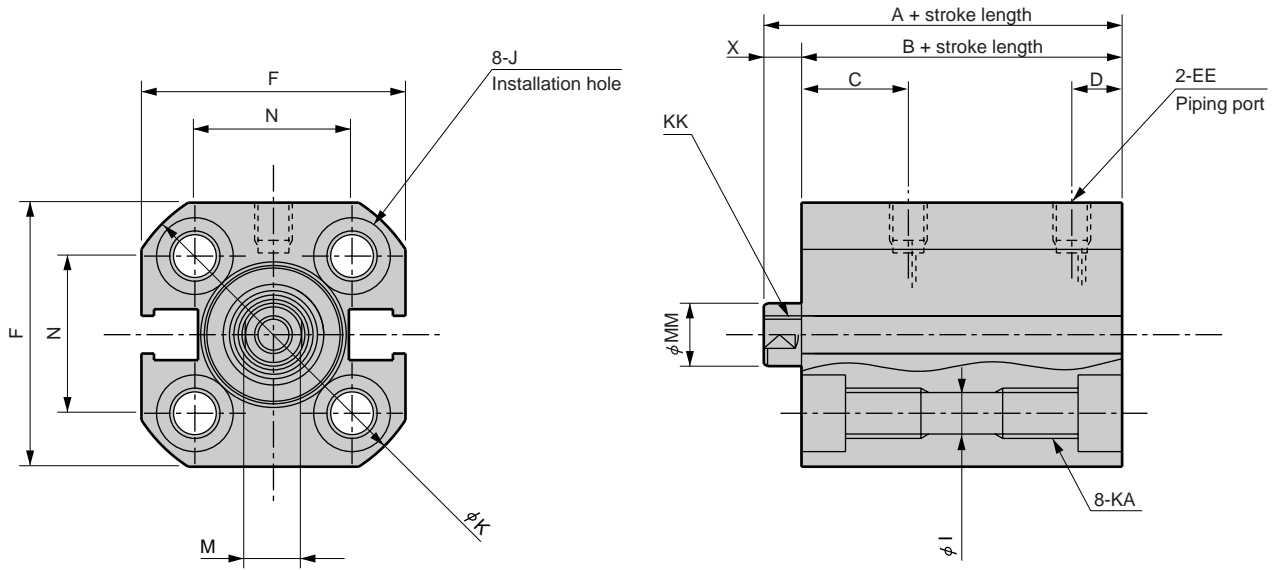

### ● MSD-K (L)-6, 8, 12-\*-R (rear common port)

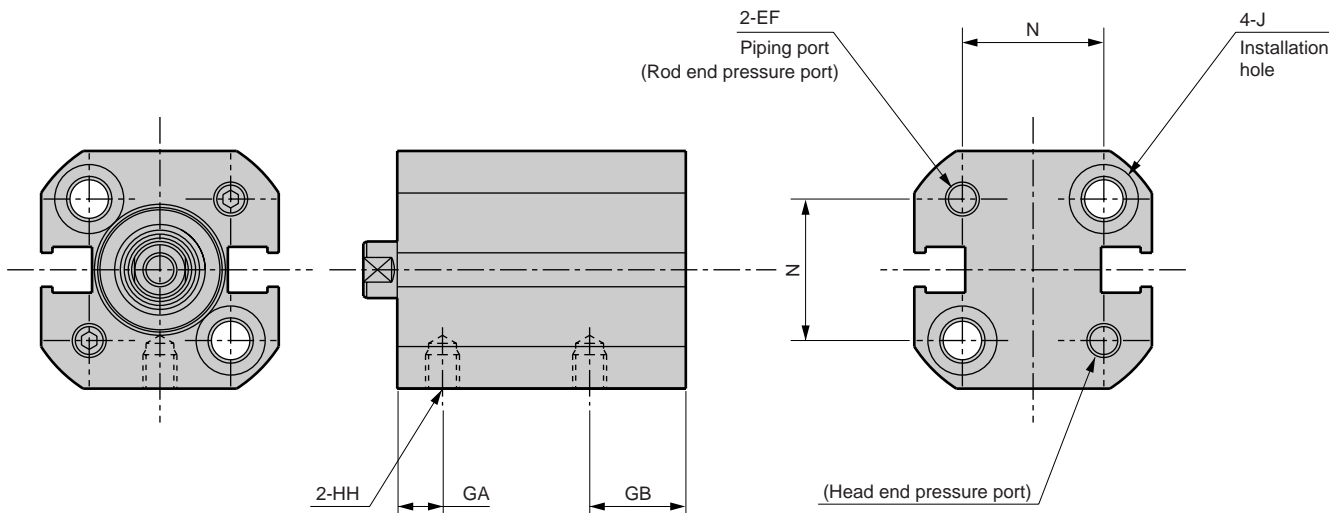

Bore size (mm)	Without switch		With switch		Without switch/common dimension with switch											
	A	B	A	B	C	D	EE	EF	F	GA	GB	HH	I	J	K	KA
φ6	22.5	19.5	27.5	24.5	7.5	4	M3	M3	19	3	8.5	M3 depth 3	3.2	Spot face φ6.1 depth 3.5	22.5	M4 depth 6
φ8	24	21	29	26	9	4	M3	M3	21	4.5	8.5	M3 depth 3	3.2	Spot face φ6.1 depth 3.5	25	M4 depth 6
φ12	25.5	22	30.5	27	11.5	5	M5	M3	25	4	10.5	M3 depth 3	3.2	Spot face φ6.1 depth 3.5	31	M4 depth 6

Bore size (mm)	Without switch/common dimension with switch				
	KK	M	MM	N	X
φ6	M2.5 depth 4	3.5	4	11	3
φ8	M3 depth 5	4.5	5	12.5	3
φ12	M3 depth 6	5	6	15.5	3.5

### Dimensions



#### ● MSD-K (L)-16

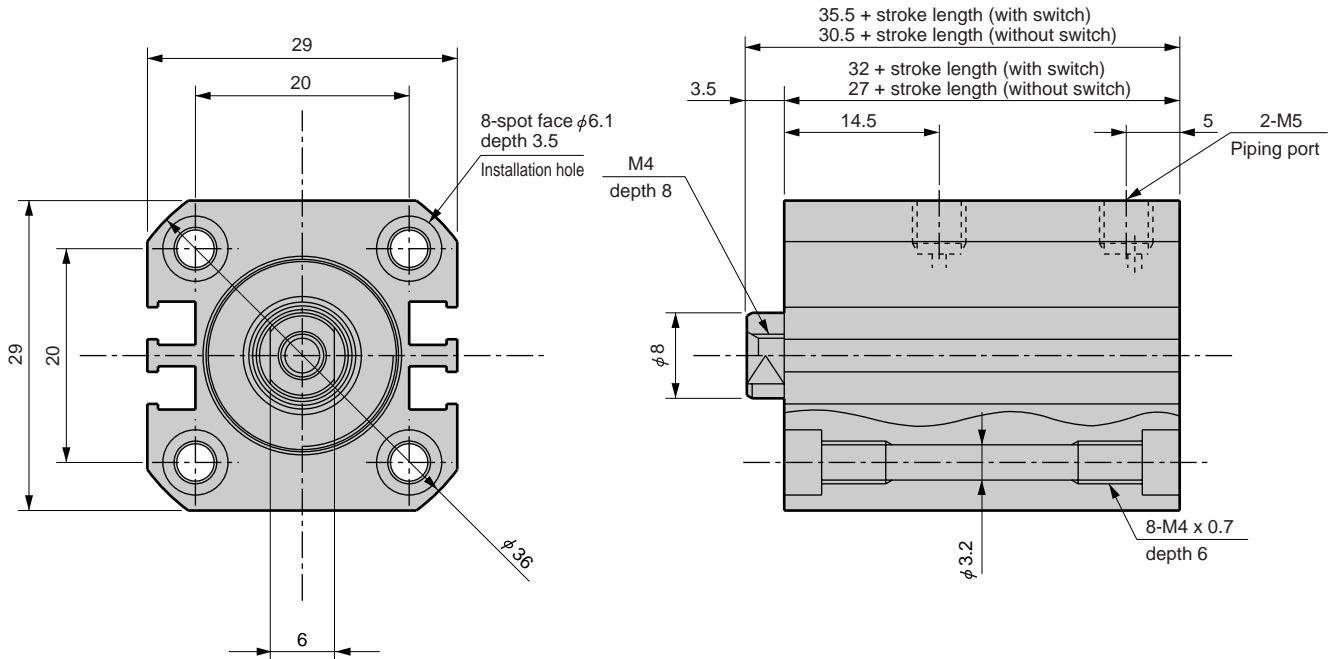

#### ● MSD-K (L)-16\*-R (rear common port)

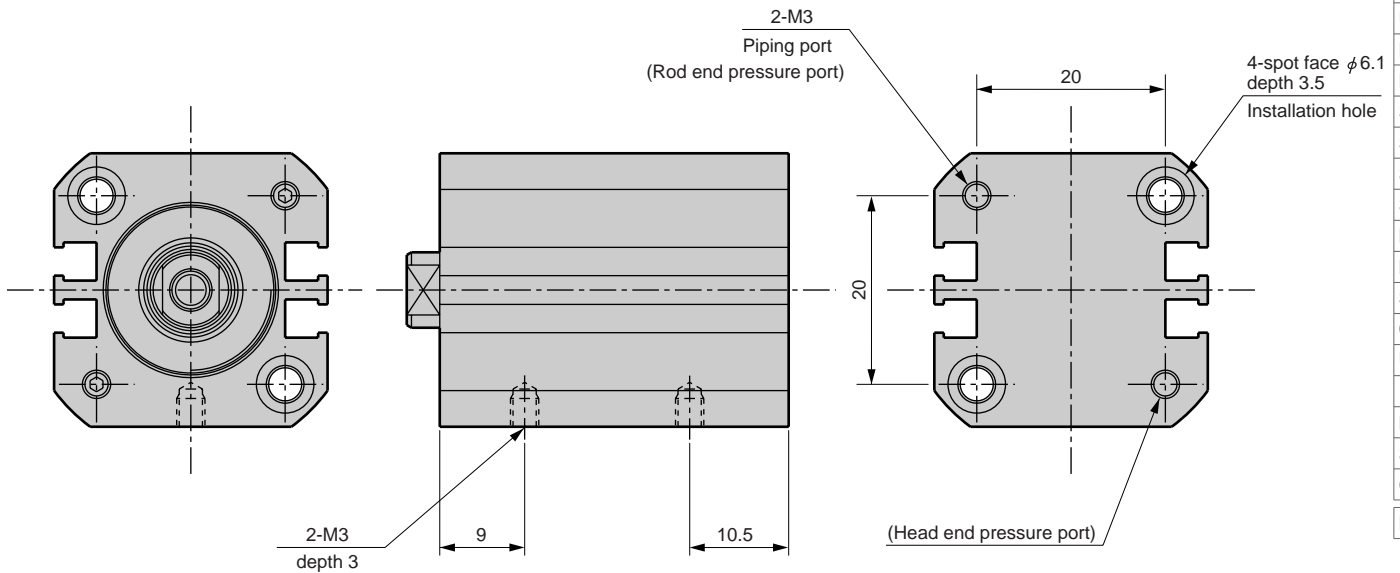

SCP*2
CMK2
CMA2
SCM
SCG
SCA2
SCS
CKV2
CA/OV2
SSD
CAT
MDC2
MVC
SMD2
<b>MSD*</b>
FC*
STK
ULK*
JSK/M2
JSG
JSC3
USSD
USC
JSB3
LMB
STG
STS/L
LCS
LCG
LCM
LCT
LCY
STR2
UCA2
HCM
HCA
SRL2
SRG
SRM
SRT
MRL2
MRG2
SM-25
CAC3
UCAC
RCC2
MFC
SHC
GLC
Ending

Small compact cylinder  
Space saving structure



## Switch installation position

### ● MSD-KL-6/8 switch installation position

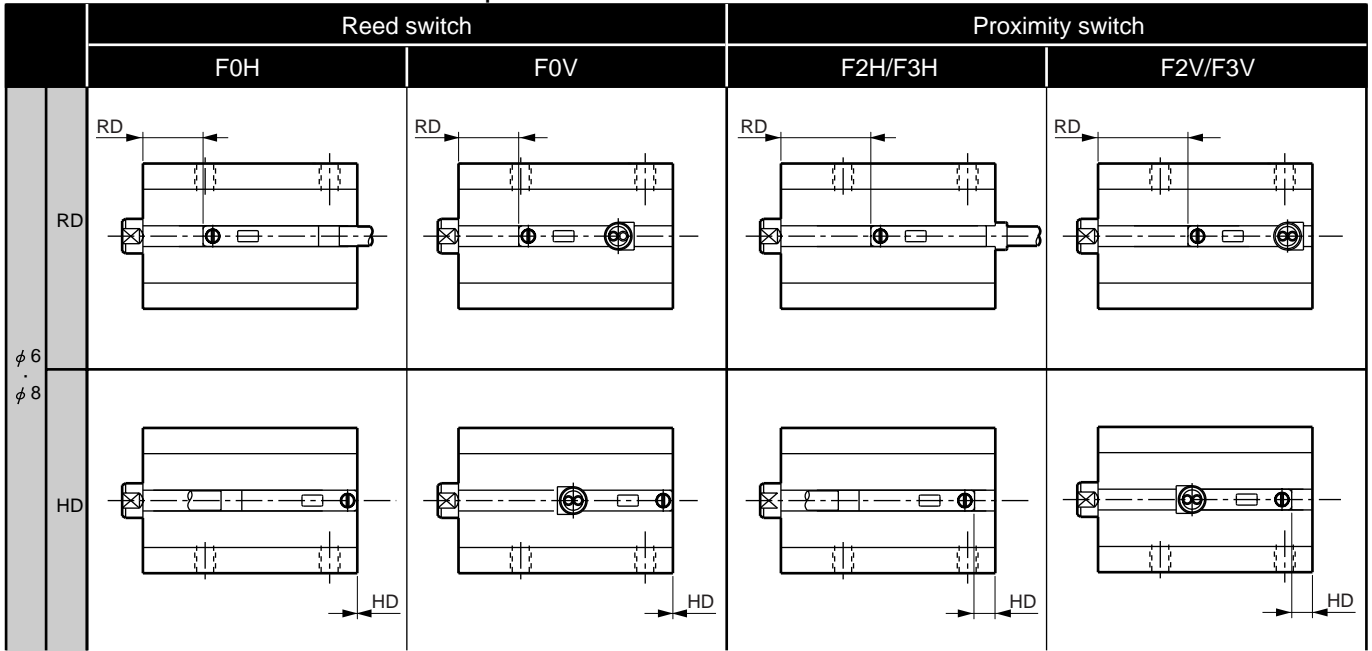

### ● MSD-KL-6/8 switch installation position dimension

(mm)

Model	Bore size (mm)	Reed switch				Proximity switch			
		F0H		F0V		F2H/F3H		F2V/F3V	
		RD	HD	RD	HD	RD	HD	RD	HD
MSD-KL	φ6	6.0	0	6.0	0	10.0	3.5	10.0	3.5
	φ8	8.5	0	8.5	0	12.5	2.5	12.5	2.5

### Switch installation position

#### ● MSD-KL-12/16 switch installation position

		Reed switch				Proximity switch			
		F0H		F0V		F2H/F3H		F2V/F3V	
φ12	RD								
	HD								
φ16	RD								
	HD								

#### ● MSD-KL-12/16 switch installation position dimension

Model	Bore size (mm)	Reed switch				Proximity switch			
		F0H		F0V		F2H/F3H		F2V/F3V	
		RD	HD	RD	HD	RD	HD	RD	HD
MSD-L	φ12	9.0	0	9.0	0	13.0	3.5	13.0	3.5
	φ16	14.0	0	14.0	0	17.5	3.5	17.5	3.5

- SCP\*2
- CMK2
- CMA2
- SCM
- SCG
- SCA2
- SCS
- CKV2
- CA/OV2
- SSD
- CAT
- MDC2
- MVC
- SMD2
- MSD\***
- FC\*
- STK
- ULK\*
- JSK/M2
- JSG
- JSC3
- USSD
- USC
- JSB3
- LMB
- STG
- STS/L
- LCS
- LCG
- LCM
- LCT
- LCY
- STR2
- UCA2
- HCM
- HCA
- SRL2
- SRG
- SRM
- SRT
- MRL2
- MRG2
- SM-25
- CAC3
- UCAC
- RCC2
- MFC
- SHC
- GLC

Ending

Small compact cylinder  
Space saving structure



Small compact cylinder, double acting fine speed type

## Single rod type **MSD-F Series**

- Bore size:  $\phi 6$ ,  $\phi 8$

## High load type **MSD-KF Series**

- Bore size:  $\phi 6$ ,  $\phi 8$ ,  $\phi 12$ ,  $\phi 16$

JIS symbol

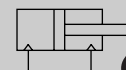

Double acting



## Specifications

Descriptions	MSD-F/MSD-LF (with switch)		MSD-KF/MSD-KLF (with switch)			
Bore size mm	$\phi 6$	$\phi 8$	$\phi 6$	$\phi 8$	$\phi 12$	$\phi 16$
Actuation	Double acting single rod type					
Working fluid	Compressed air					
Max. working pressure MPa	1.0					
Min. working pressure MPa	0.15		0.15		0.1	
Withstanding pressure MPa	1.6					
Ambient temperature °C	5 to 60					
Port size	Body side surface port	M3		M3		M5
	Rear common port	-		-		M3
Stroke tolerance mm	$^{+0.5}_0$		$^{+2.0}_0$			
Working piston speed mm/s	1 to 200					
Cushion	None			Rubber cushioned		
Lubrication	Must be oil free					
Allowable energy absorption J	Non-cushion type cannot absorb an external force generated by a load installed on the cylinder. Use this with loadless, select a cushioned type, or provide an external shock.		0.004	0.014	0.044	0.110

## Stroke length

Bore size (mm)	Standard stroke length (mm)	Max. stroke length (mm)	Min. stroke length with 2 switches (mm)		Min. stroke length with 1 switch (mm)	
			Reed switch	Proximity switch	Reed switch	Proximity switch
$\phi 6$	5, 10, 15, 20, 25, 30	30	10	5	5	5
$\phi 8$	5, 10, 15, 20, 25, 30	30	10	5	5	5
$\phi 12$	5, 10, 15, 20, 25, 30	30	10	5	5	5
$\phi 16$	5, 10, 15, 20, 25, 30	30	10	5	5	5

Note: Other than standard stroke length is not available.

## Switch specifications

Descriptions	Reed 2 wire	Proximity 2 wire	Proximity 3 wire
	F0H/V	F2H/V	F3H/V
Applications	Programmable controller		Programmable controller, relay
Output method	-		NPN output
Power voltage	-	-	10 to 28 VDC
Load voltage	24 VDC	10 to 30 VDC	30 VDC or less
Load current	5 to 20mA (Note 1)	5 to 20mA (Note 1)	50mA or less
Current consumption	-	-	(When turned ON) 10mA or less with 24 VDC
Internal voltage drop	4V or less		0.5V or less
Light	Yellow LED (ON lighting)		
Leakage current	1mA or less		10 $\mu$ A or less
Lead wire length (standard)	Standard 1m (oil resistant vinyl cabtire code 2 conductor 0.15mm <sup>2</sup> )		Standard 1m (oil resistant vinyl cabtire code 3 conductor 0.15mm <sup>2</sup> )
Maximum shock resistance	294m/s <sup>2</sup>		980m/s <sup>2</sup>
Insulation resistance	20M $\Omega$ and over with 500 VDC megger		
Withstand voltage	No failure at 1000 VAC for one minute.		
Ambient temperature	-10 to + 60 °C		
Protective structure	IEC standards IP67, JIS C 0920 (water tight type), oil resistance		

Note 1: Max. load current 29mA is the value at 25 °C.

The current will be lower than 20mA if ambient temperature around switch is higher than 20mA.  
(5 to 10mA at 60°C)

## Dimensions

It is the same as double acting single rod type MSD series or double acting high load type MSD-K Series. Refer to Pages1053, 1072 and 1073.

### How to order

● Without switch

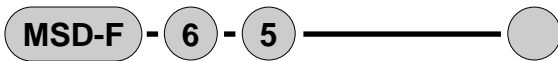

● With switch

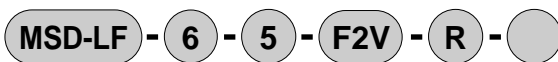

A Model no.

B Bore size

C Stroke length

D Switch model no.  
Note 1  
Note 2  
\* indicates lead wire length.

E Switch quantity

F Piping port position  
Note 3

### ⚠ Cautions on model no. selection

Note 1: For 6, 8 mm bore cylinders with reed switches, use mounting bolts that do not contain magnetic substances (stainless steel etc.).

Note 2: For 6, 8 mm bore cylinders with proximity switches, use mounting bolts that do not contain magnetic substances (stainless steel etc.).

For 12, 16 mm bore cylinders, if used with through bolts, use mounting bolts that do not contain magnetic substances (stainless steel etc.).

Note 3: For rear common port type, a side installation is possible. In this case, two bolts are used for head or rod side installation.

### <Example of model number>

#### MSD-KLF-12-10-F0H-R-R

Model: Small compact cylinder fine speed type

- A Model no. : Double acting high load type
- B Bore size :  $\phi$  12mm
- C Stroke length : 10mm
- D Switch model no. : Reed switch F0H, lead wire 1m
- E Switch quantity : 1 on rod end
- F Piping port position : Rear common port

### How to order switch



Switch model no.  
(Item D above)

A Model no.	
Double acting single rod type MSD	Double acting high load type MSD-K

Symbol	Descriptions	Double acting single rod type MSD	Double acting high load type MSD-K
<b>B Bore size (mm)</b>			
6	$\phi$ 6	●	●
8	$\phi$ 8	●	●
12	$\phi$ 12		●
16	$\phi$ 16		●

<b>C Stroke length (mm)</b>			
5	5	●	●
10	10	●	●
15	15	●	●
20	20	●	●
25	25	●	●
30	30	●	●

<b>D Switch model no.</b>					
Axial lead wire	Radial lead wire	Contact	Indicator	Lead wire	
F0H*	F0V*	Reed	1 color indicator type	2-wire	●
F2H*	F2V*	Proximity		3-wire	●
F3H*	F3V*				●

<b>*Lead wire length</b>			
Blank	1m (standard)	●	●
3	3m (option)	●	●

<b>E Switch quantity</b>			
R	1 on rod end	●	●
H	1 on head end	●	●
D	Two	●	●

<b>F Piping port position</b>						
	Bore size ( $\phi$ )	All bore sizes	6	8	12	16
Blank	Body side surface port	●	●	●	●	●
R	Rear common port				●	●

- SCP\*2
- CMK2
- CMA2
- SCM
- SCG
- SCA2
- SCS
- CKV2
- CA/OV2
- SSD
- CAT
- MDC2
- MVC
- SMD2
- MSD\*
- FC\*
- STK
- ULK\*
- JSK/M2
- JSG
- JSC3
- USSD
- USC
- JSB3
- LMB
- STG
- STS/L
- LCS
- LCG
- LCM
- LCT
- LCY
- STR2
- UCA2
- HCM
- HCA
- SRL2
- SRG
- SRM
- SRT
- MRL2
- MRG2
- SM-25
- CAC3
- UCAC
- RCC2
- MFC
- SHC
- GLC

Ending

Small compact cylinder  
Space saving structure

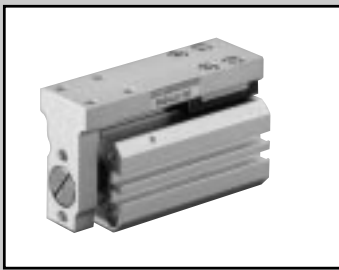

Small guided compact cylinder  
Double acting guided type/with switch

# MSDG-L Series

● Bore size:  $\phi 6$ ,  $\phi 8$ ,  $\phi 12$ ,  $\phi 16$



## Specifications

Descriptions		MSDG-L (with switch)			
Bore size	mm	$\phi 6$	$\phi 8$	$\phi 12$	$\phi 16$
Actuation		Double acting			
Working fluid		Compressed air			
Max. working pressure MPa		1.0			
Min. working pressure MPa		0.2	0.15		0.1
Withstanding pressure MPa		1.6			
Ambient temperature $^{\circ}\text{C}$		5 to 60			
Connection	Body side surface port	M3		M5	
	Port size Rear common port	M3		M3	
Stroke tolerance	mm	+2.0			
		0			
Working piston speed mm/s		50 to 500			
Lubrication		Not required (when lubricating, use turbine oil ISO VG32.)			

## Stroke length

Bore size (mm)	Standard stroke length (mm)	Max. stroke length (mm)	Min. stroke length with 2 switches (mm)		Min. stroke length with 1 switch (mm)	
			Reed switch	Proximity switch	Reed switch	Proximity switch
$\phi 6$	5, 10, 15, 20, 25, 30	30	10	5	5	5
$\phi 8$	5, 10, 15, 20, 25, 30	30	10	5	5	5
$\phi 12$	5, 10, 15, 20, 25, 30	30	10	5	5	5
$\phi 16$	5, 10, 15, 20, 25, 30	30	10	5	5	5

Note: Other than standard stroke length is not available.

## Switch specifications

Descriptions	Reed 2 wire	Proximity 2 wire	Proximity 3 wire
	F0H/V	F2H/V	F3H/V
Applications	Programmable controller		Programmable controller, relay
Output method	-		NPN output
Power voltage	-	-	10 to 28 VDC
Load voltage	24 VDC	10 to 30 VDC	30 VDC or less
Load current	5 to 20mA (Note 1)	5 to 20mA (Note 1)	50mA or less
Current consumption	-	-	(When turned ON) 10mA or less with 24 VDC
Internal voltage drop	4V or less		0.5V or less
Light	Yellow LED (ON lighting)		
Leakage current	1mA or less		10 $\mu\text{A}$ or less
Lead wire length (standard)	Standard 1m (oil resistant vinyl cabtire code 2 conductor 0.15mm <sup>2</sup> )		Standard 1m (oil resistant vinyl cabtire code 3 conductor 0.15mm <sup>2</sup> )
Maximum shock resistance	294m/s <sup>2</sup>	980m/s <sup>2</sup>	
Insulation resistance	20M $\Omega$ and over with 500 VDC megger		
Withstand voltage	No failure at 1000 VAC for one minute.		
Ambient temperature	-10 to +60 $^{\circ}\text{C}$		
Protective structure	IEC standards IP67, JIS C 0920 (water tight type), oil resistance		

Note 1: Max. load current 29mA is the value at 25  $^{\circ}\text{C}$ .

The current will be lower than 20mA if ambient temperature around switch is higher than 20mA.  
(5 to 10mA at 60 $^{\circ}\text{C}$ )

Cylinder weight table

Stroke length (mm)	5	10	15	20	25	30	Weight per 1 switch
Bore size (mm)							10
φ6	43	48	52	57	61	66	
φ8	50	56	63	69	76	82	
φ12	76	88	100	112	124	136	
φ16	129	146	163	180	197	214	

(g)

- SCP\*2
- CMK2
- CMA2
- SCM
- SCG
- SCA2
- SCS
- CKV2
- CA/OV2
- SSD
- CAT
- MDC2
- MVC
- SMD2
- MSD\*
- FC\*
- STK
- ULK\*
- JSK/M2
- JSG
- JSC3
- USSD
- USC
- JSB3
- LMB
- STG
- STS/L
- LCS
- LCG
- LCM
- LCT
- LCY
- STR2
- UCA2
- HCM
- HCA
- SRL2
- SRG
- SRM
- SRT
- MRL2
- MRG2
- SM-25
- CAC3
- UCAC
- RCC2
- MFC
- SHC
- GLC
- Ending

Small compact cylinder  
Space saving structure

# MSDG-L Series

- SCP\*2
- CMK2
- CMA2
- SCM
- SCG
- SCA2
- SCS
- CKV2
- CA/OV2
- SSD
- CAT
- MDC2
- MVC
- SMD2
- MSD\***
- FC\*
- STK
- ULK\*
- JSK/M2
- JSG
- JSC3
- USSD
- USC
- JSB3
- LMB
- STG
- STS/L
- LCS
- LCG
- LCM
- LCT
- LCY
- STR2
- UCA2
- HCM
- HCA
- SRL2
- SRG
- SRM
- SRT
- MRL2
- MRG2
- SM-25
- CAC3
- UCAC
- RCC2
- MFC
- SHC
- GLC
- Ending

## How to order

● With switch

**MSDG-L - 6 - 30 - F0H - D - R**

Double acting  
guided type

**A** Bore size

**B** Stroke length

**C** Switch model no.  
Note 1  
Note 2

**D** Switch quantity

**E** Piping port position  
Note 3

### ⚠ Note on model no. selection

Note 1: For 6, 8 mm bore cylinders with reed switches, use mounting bolts that do not contain magnetic substances (stainless steel etc.).

Note 2: For 6, 8 mm bore cylinders with proximity switches, use mounting bolts that do not contain magnetic substances (stainless steel etc.).

For 12, 16 mm bore cylinders, if used with through bolts, use mounting bolts that do not contain magnetic substances (stainless steel etc.).

Note 3: For rear common port type, a side installation is possible.

<Example of model number>

**MSDG-L-6-30-F0H-D-R**

- A** Bore size :  $\phi$  6mm
- B** Stroke length : 30mm
- C** Switch model no. : Reed F0H
- D** Switch quantity : Two
- E** Option : Rear common port

Symbol	Descriptions			
<b>A Bore size (mm)</b>				
6	$\phi$ 6			
8	$\phi$ 8			
12	$\phi$ 12			
16	$\phi$ 16			
<b>B Stroke length (mm)</b>				
5	5			
10	10			
15	15			
20	20			
25	25			
30	30			
<b>D Switch model no.</b>				
Axial lead wire	Radial lead wire	Contact	Indicator	Lead wire
F0H*	F0V*	Reed	1 color indicator type	2-wire
F2H*	F2V*	Proximity		3-wire
F3H*	F3V*			
<b>*Lead wire length</b>				
Blank	1m (standard)			
3	3m (option)			
<b>D Switch quantity</b>				
R	1 on rod end			
H	1 on head end			
D	Two			
<b>E Piping port position</b>				
Blank	Body side surface port			
R	Rear common port			

## How to order switch

**SW - F0H**

Switch model no.  
(Item **D** above)

### Switch selection table

Switches could not be installed depending on relations between cylinder installation and stroke length. Refer to the table below to select a switch.

All switches can be used when side installation. (Refer to page 1076 for min. stroke length with switch)

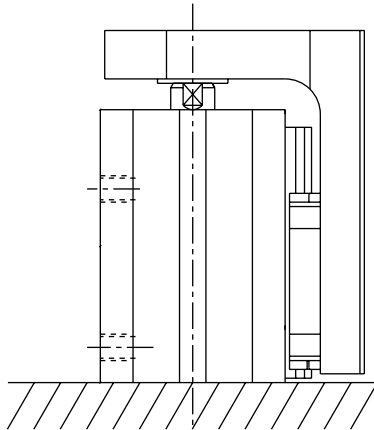

(H) Head end installation

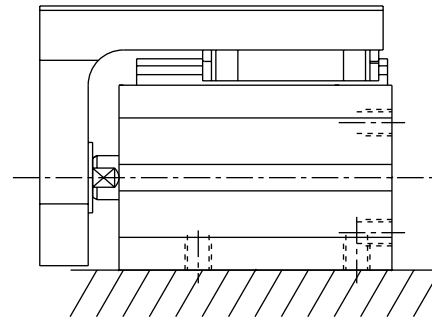

Side installation

### ● Head end installation

Bore size (mm)	Stroke length (mm)	Reed switch				Proximity switch			
		F0H		F0V		F2H/F3H		F2V/F3V	
		Switch installation position		Switch installation position		Switch installation position		Switch installation position	
		R	H	R	H	R	H	R	H
φ6	5	X	○	○	○	X	○	○	○
	10	○	○	○	○	X	○	○	○
	15 to	○	○	○	○	○	○	○	○
φ8	5	X	○	○	○	X	○	○	○
	10	○	○	○	○	X	○	○	○
	15 to	○	○	○	○	○	○	○	○
φ12	5	X	○	○	○	X	○	○	○
	10	○	○	○	○	X	○	○	○
	15 to	○	○	○	○	○	○	○	○
φ16	5	X	○	○	○	X	○	○	○
	10	○	○	○	○	X	○	○	○
	15 to	○	○	○	○	○	○	○	○

- SCP\*2
- CMK2
- CMA2
- SCM
- SCG
- SCA2
- SCS
- CKV2
- CA/OV2
- SSD
- CAT
- MDC2
- MVC
- SMD2
- MSD\***
- FC\*
- STK
- ULK\*
- JSK/M2
- JSG
- JSC3
- USSD
- USC
- JSB3
- LMB
- STG
- STS/L
- LCS
- LCG
- LCM
- LCT
- LCY
- STR2
- UCA2
- HCM
- HCA
- SRL2
- SRG
- SRM
- SRT
- MRL2
- MRG2
- SM-25
- CAC3
- UCAC
- RCC2
- MFC
- SHC
- GLC
- Ending

Small compact cylinder  
Space saving structure



## Internal structure and parts list

SCP*2
CMK2
CMA2
SCM
SCG
SCA2
SCS
CKV2
CA/OV2
SSD
CAT
MDC2
MVC
SMD2
<b>MSD*</b>
FC*
STK
ULK*
JSK/M2
JSG
JSC3
USSD
USC
JSB3
LMB
STG
STS/L
LCS
LCG
LCM
LCT
LCY
STR2
UCA2
HCM
HCA
SRL2
SRG
SRM
SRT
MRL2
MRG2
SM-25
CAC3
UCAC
RCC2
MFC
SHC
GLC
Ending

●MSDG-L-6, 8, 12

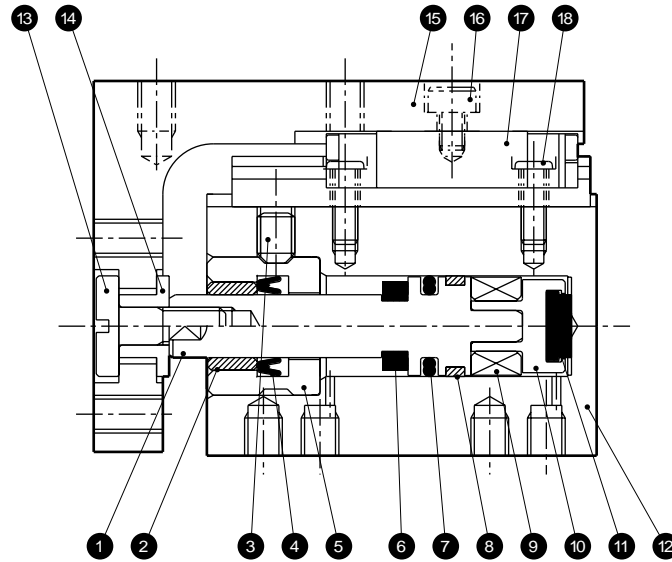

●MSDG-L-16

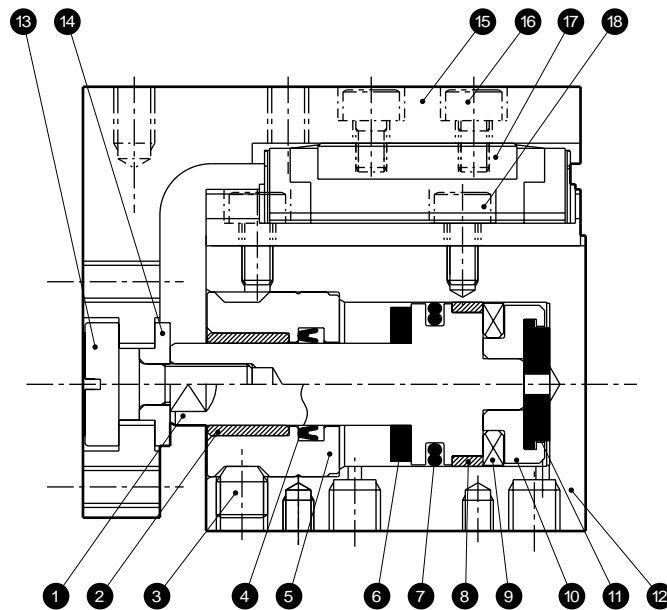

No.	Parts name	Material	Remarks	No.	Parts name	Material	Remarks
1	Piston	Stainless steel		10	Adaptor	Aluminum alloy	
2	Bush	Oil impregnated copper alloy		11	Cushion rubber H	Urethane rubber	
3	Hexagon socket head set screw	Stainless steel		12	Body	Aluminum alloy	Alumite
4	Rod packing seal	Nitrile rubber		13	Floating bolt	Steel	Nickeling
5	Rod bushing	Stainless steel		14	Floating bush	Stainless steel	
6	Cushion rubber R	Urethane rubber		15	Table	Aluminum alloy	Alumite
7	Piston packing seal	Nitrile rubber		16	Hexagon socket head cap bolt	Stainless steel	
8	Wear ring	Acetar resin		17	High precision guide	Stainless steel	
9	Magnet	Plastic		18	Bolt	Stainless steel	

# MSDG-L Series

## Dimensions



### ● MSDG-L-6, 8, 12

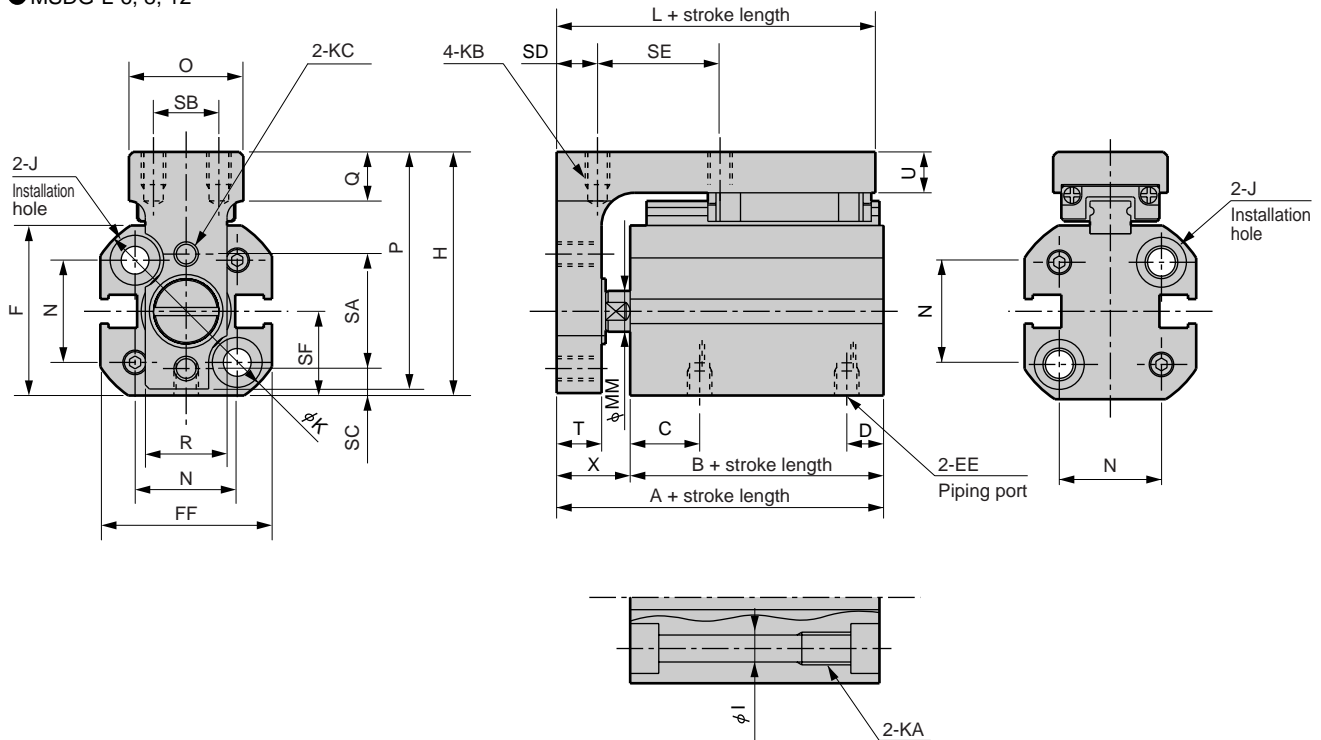

### ● MSDG-L-6, 8, 12-\*R (rear common port)

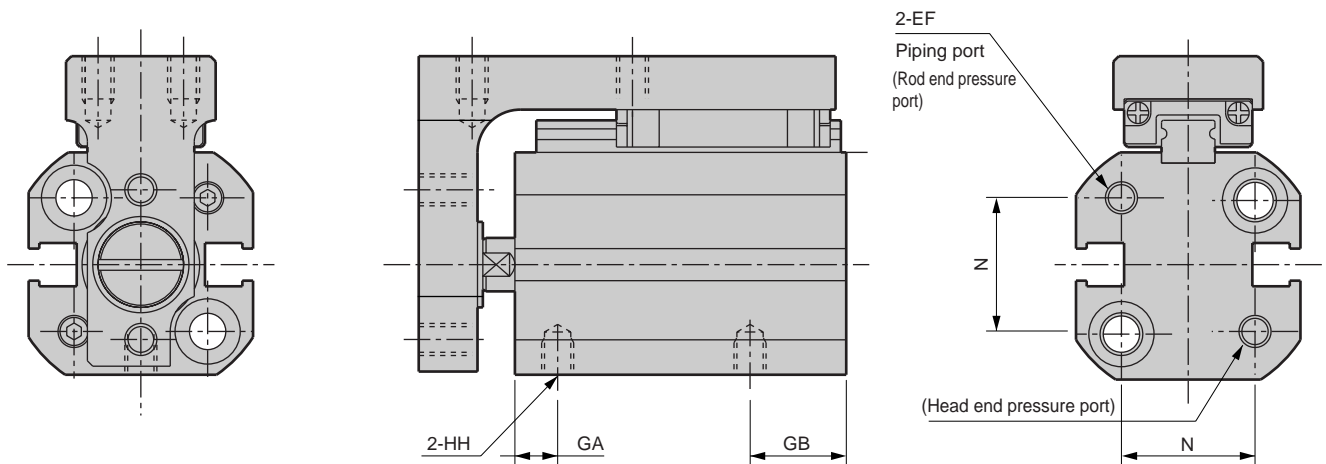

Symbol	A	B	C	D	EE	EF	F	FF	GA	GB	H	HH	I	J	K	KA	KB	KC
Bore size (mm)																		
φ6	33.5	24.5	7.5	4	M3	M3	18.8	19	3	8.5	27.8	M3 depth 3	3.2	Spot face φ6.1 depth 3.5	22.5	M4 depth 6	M3 depth 4	M3 (penetrating)
φ8	35	26	9	4	M3	M3	20.8	21	4.5	8.5	29.8	M3 depth 3	3.2	Spot face φ6.1 depth 3.5	25	M4 depth 6	M3 depth 4	M3 (penetrating)
φ12	38	27	11.5	5	M5	M3	24.8	25	4	10.5	36.3	M3 depth 3	3.2	Spot face φ6.1 depth 3.5	31	M4 depth 6	M3 depth 4.5	M3 (penetrating)

Symbol	L	MM	N	O	P	Q	R	SA	SB	SC	SD	SE	SF	T	U	X
Bore size (mm)																
φ6	32	4	11	14	27	6	9.5	12	8	3.3	5	15	9.3	5.5	5	9
φ8	33.5	5	12.5	14	29	6	10	14	8	3.3	5	15	10.3	5.5	5	9
φ12	36.5	6	15.5	19	35	6.5	13	15.5	12	4.5	5	15	12.3	7	6.5	11

### Dimensions



#### ● MSDG-L-16

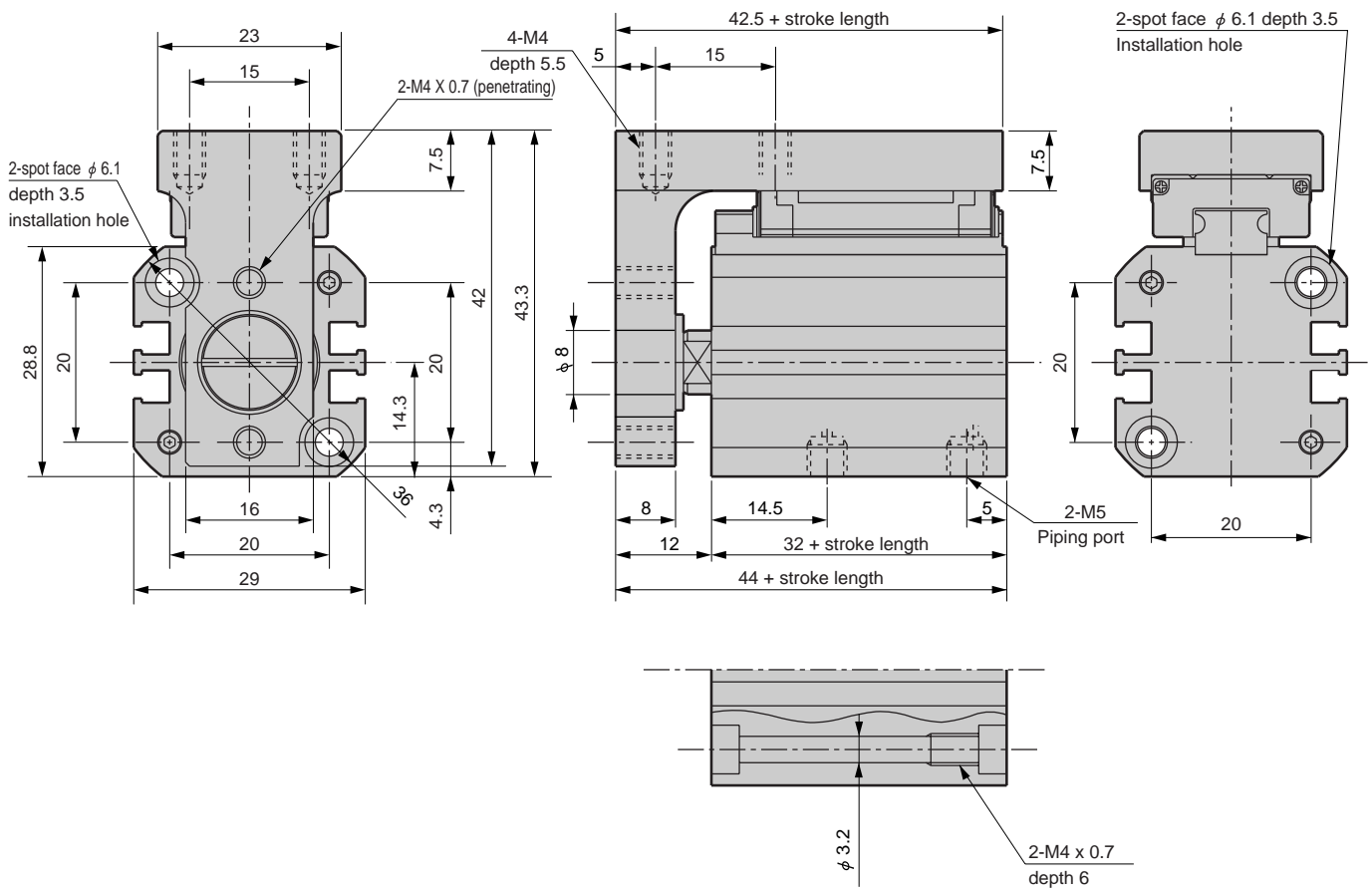

#### ● MSDG-L-16\*-R (rear common port)

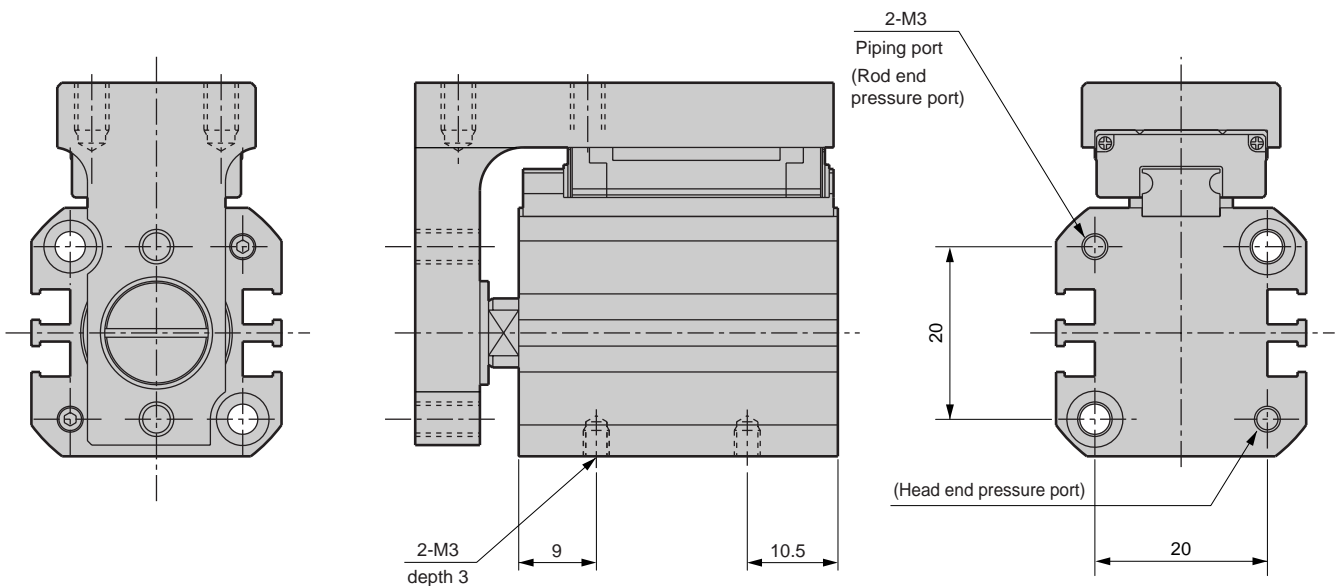

SCP*2
CMK2
CMA2
SCM
SCG
SCA2
SCS
CKV2
CA/OV2
SSD
CAT
MDC2
MVC
SMD2
<b>MSD*</b>
FC*
STK
ULK*
JSK/M2
JSG
JSC3
USSD
USC
JSB3
LMB
STG
STS/L
LCS
LCG
LCM
LCT
LCY
STR2
UCA2
HCM
HCA
SRL2
SRG
SRM
SRT
MRL2
MRG2
SM-25
CAC3
UCAC
RCC2
MFC
SHC
GLC
Ending

Small compact cylinder  
Space saving structure

## Switch installation position

### ● MSDG-L-6/8 installation position

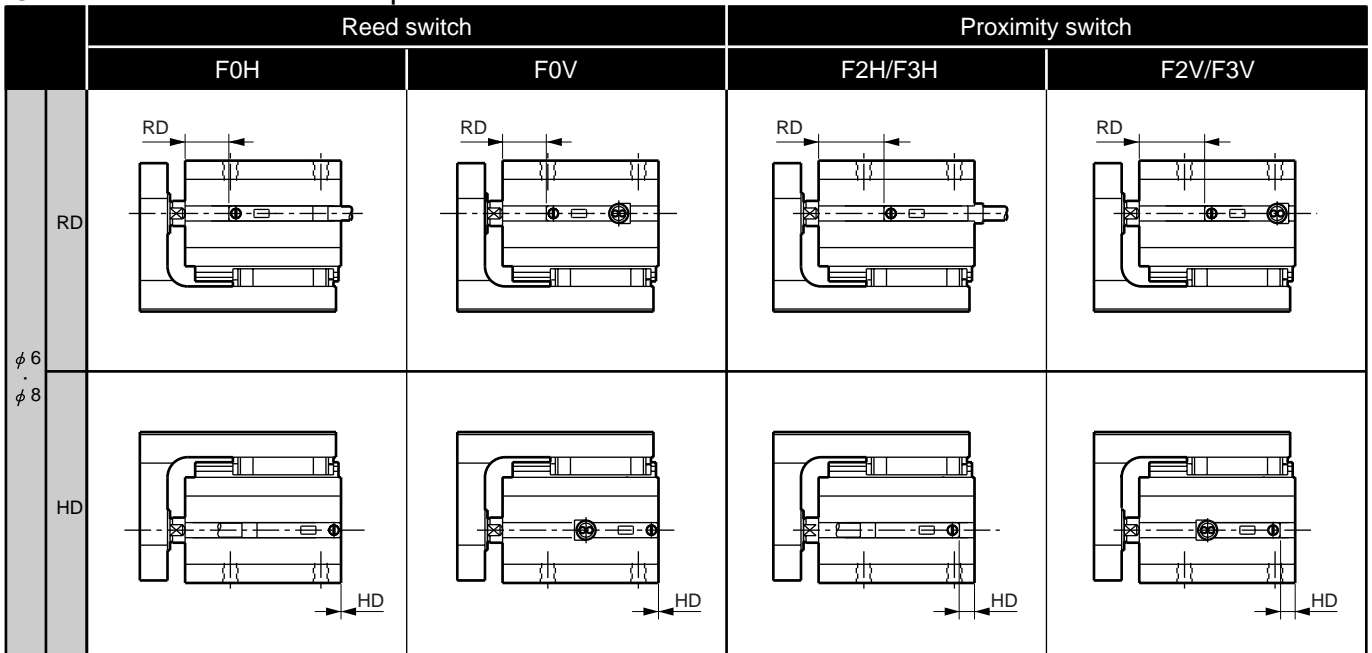

### ● MSDG-L-6/8 switch installation position dimension

(mm)

Model	Bore size (mm)	Reed switch				Proximity switch			
		F0H		F0V		F2H/F3H		F2V/F3V	
		RD	HD	RD	HD	RD	HD	RD	HD
MSDG	$\phi 6$	6.0	0	6.0	0	10.0	3.5	10.0	3.5
	$\phi 8$	8.5	0	8.5	0	12.5	2.5	12.5	2.5

### Switch installation position

#### ● MSDG-L-12/16 installation position

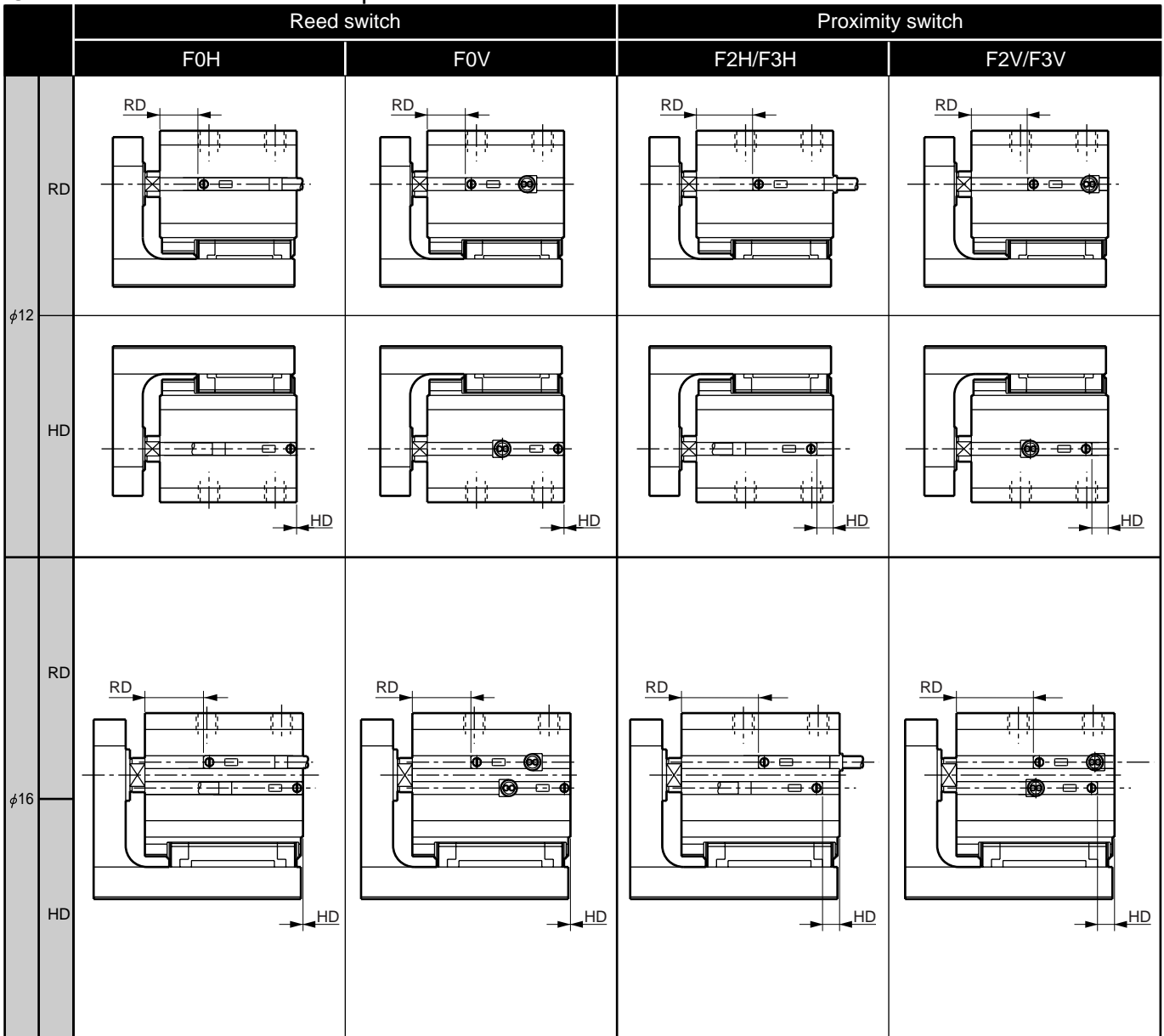

#### ● MSDG-L-12/16 switch installation position dimension

Model	Bore size (mm)	Reed switch				Proximity switch			
		F0H		F0V		F2H/F3H		F2V/F3V	
		RD	HD	RD	HD	RD	HD	RD	HD
MSDG	φ12	9.0	0	9.0	0	13.0	3.5	13.0	3.5
	φ16	14.0	0	14.0	0	17.5	3.5	17.5	3.5

SCP\*2  
CMK2  
CMA2  
SCM  
SCG  
SCA2  
SCS  
CKV2  
CA/OV2  
SSD  
CAT  
MDC2  
MVC  
SMD2  
MSD\*  
FC\*  
STK  
ULK\*  
JSK/M2  
JSG  
JSC3  
USSD  
USC  
JSB3  
LMB  
STG  
STS/L  
LCS  
LCG  
LCM  
LCT  
LCY  
STR2  
UCA2  
HCM  
HCA  
SRL2  
SRG  
SRM  
SRT  
MRL2  
MRG2  
SM-25  
CAC3  
UCAC  
RCC2  
MFC  
SHC  
GLC

Ending

Small compact cylinder  
Space saving structure

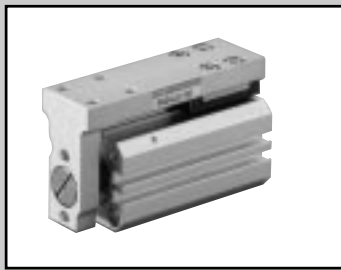

# Small guided compact cylinder

Double acting guided fine speed types/with switch

## MSDG-LF Series

● Bore size:  $\phi$  12,  $\phi$  16



### Specifications

Descriptions	MSDG-LF	
	$\phi$ 12	$\phi$ 16
Bore size mm	$\phi$ 12	$\phi$ 16
Actuation	Double acting guided type	
Working fluid	Compressed air	
Max. working pressure MPa	1.0	
Min. working pressure MPa	0.1	
Withstanding pressure MPa	1.6	
Ambient temperature °C	5 to 60	
Port size	Body side surface port	M5
	Rear common port	M3
Stroke tolerance mm	$^{+2.0}_0$	
Working piston speed mm/s	1 to 200	
Cushion	Rubber cushioned	
Lubrication	Not available	
Allowable energy absorption J	0.044	0.110

### Stroke length

Bore size (mm)	Standard stroke length (mm)	Max. stroke length (mm)	Min. stroke length with 2 switches (mm)		Min. stroke length with 1 switch (mm)	
			Reed switch	Proximity switch	Reed switch	Proximity switch
$\phi$ 12	5, 10, 15, 20, 25, 30	30	10	5	5	5
$\phi$ 16	5, 10, 15, 20, 25, 30	30	10	5	5	5

Note: Other than standard stroke length is not available.

### Switch specifications

Descriptions	Reed switch	Proximity switch	
	F0H/V	F2H/V	F3H/V
Applications	Programmable controller		Programmable controller, relay
Output method	-		NPN output
Power voltage	-	-	10 to 28 VDC
Load voltage	24 VDC	10 to 30 VDC	30 VDC or less
Load current	5 to 20mA (Note 1)	5 to 20mA (Note 1)	50mA or less
Current consumption	-	-	(When turned ON) 10mA or less with 24 VDC
Internal voltage drop	4V or less		0.5V or less
Light	Yellow LED (ON lighting)		
Leakage current	1mA or less		10 $\mu$ A or less
Lead wire length (standard)	Standard 1m (oil resistant vinyl cabtire code 2 conductor 0.15mm <sup>2</sup> )		Standard 1m (oil resistant vinyl cabtire code 3 conductor 0.15mm <sup>2</sup> )
Maximum shock resistance	294m/s <sup>2</sup>		980m/s <sup>2</sup>
Insulation resistance	20M $\Omega$ and over with 500 VDC megger		
Withstand voltage	No failure at 1000 VAC for one minute.		
Ambient temperature	-10 to + 60°C		
Protective structure	IEC standards IP67, JIS C 0920 (water tight type), oil resistance		

Note 1:Max. load current 29mA is the value at 25 °C .

The current will be lower than 20mA if ambient temperature around switch is higher than 20mA.  
(5 to 10mA at 60°C )

### How to order

● With switch

**MSDG-LF** - **12** - **10** - **F2V** - **R** - **R**

Model no.

**A** Bore size

**B** Stroke length

**C** Switch model no.  
Note 1 |  
\* indicates lead wire length.

**D** Switch quantity

**E** Piping port position  
Note 2

Symbol	Descriptions			
<b>A Bore size (mm)</b>				
12	φ12			
16	φ16			
<b>B Stroke length (mm)</b>				
5	5			
10	10			
15	15			
20	20			
25	25			
30	30			
<b>C Switch model no.</b>				
Axial lead wire	Radial lead wire	Contact	Indicator	Lead wire
<b>F0H*</b>	<b>F0V*</b>	Reed	1 color indicator type	2-wire
<b>F2H*</b>	<b>F2V*</b>	Proximity		3-wire
<b>F3H*</b>	<b>F3V*</b>			
<b>*Lead wire length</b>				
Blank	1m (standard)			
3	3m (option)			
<b>D Switch quantity</b>				
<b>R</b>	1 on rod end			
<b>H</b>	1 on head end			
<b>D</b>	Two			
<b>E Piping port position</b>				
<b>Blank</b>	Body side surface port			
<b>R</b>	Rear common port			

### Note on model no. selection

Note 1: For 12, 16 mm bore cylinders with proximity switches, if used with through bolts, use mounting bolts that do not contain magnetic substances (stainless steel etc.).

Note 2: For rear common port type, a side installation is possible.

### <Example of model number>

#### MSDG-LF-12-10-F0H-R-R

Model: Small guided compact cylinder fine speed type

- A** Bore size : φ 12mm
- B** Stroke length : 10mm
- C** Switch model no. : Reed switch F0H, lead wire 1m
- D** Switch quantity : 1 on rod end
- E** Piping port position : Rear common port

### How to order switch

**SW** - **F0H**

Switch model no.  
(Item **D** above)

### Dimensions

It is the same as the double acting guided type MSDG-L series. Refer to pages 1084, 1085.

SCP\*2  
CMK2  
CMA2  
SCM  
SCG  
SCA2  
SCS  
CKV2  
CA/OV2  
SSD  
CAT  
MDC2  
MVC  
SMD2  
MSD\*  
FC\*  
STK  
ULK\*  
JSK/M2  
JSG  
JSC3  
USSD  
USC  
JSB3  
LMB  
STG  
STS/L  
LCS  
LCG  
LCM  
LCT  
LCY  
STR2  
UCA2  
HCM  
HCA  
SRL2  
SRG  
SRM  
SRT  
MRL2  
MRG2  
SM-25  
CAC3  
UCAC  
RCC2  
MFC  
SHC  
GLC

Ending

Small compact cylinder  
Space saving structure

SCP\*2  
CMK2  
CMA2  
SCM  
SCG  
SCA2  
SCS  
CKV2  
CA/OV2  
SSD  
CAT  
MDC2  
MVC  
SMD2  
MSD\*  
FC\*  
STK  
ULK\*  
JSK/M2  
JSG  
JSC3  
USSD  
USC  
JSB3  
LMB  
STG  
STS/L  
LCS  
LCG  
LCM  
LCT  
LCY  
STR2  
UCA2  
HCM  
HCA  
SRL2  
SRG  
SRM  
SRT  
MRL2  
MRG2  
SM-25  
CAC3  
UCAC  
RCC2  
MFC  
SHC  
GLC  
Ending

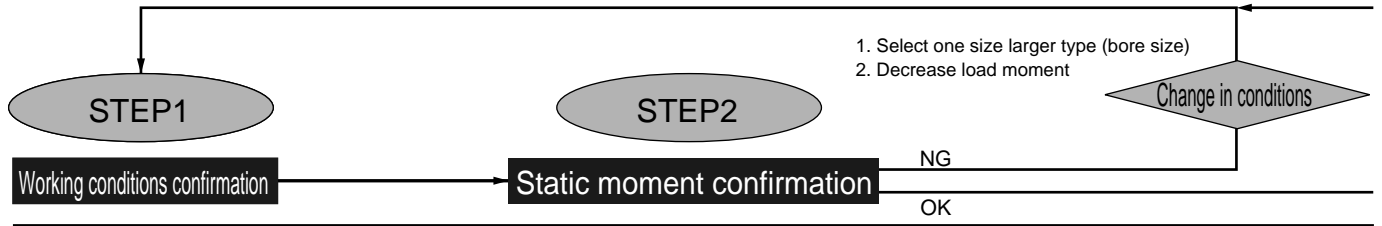

1. Select one size larger type (bore size)
2. Decrease load moment

### STEP1 Working conditions confirmation

- |  |  |
|--|--|
| 1. Bore size : D (mm)                                  | 6. Load installation attitude : M1, M2, M3 direction |
| 2. Stroke length : St (mm)                             | 7. Load weight : m1, m2, m3 (kg)                     |
| 3. Working pressure : P (MPa)                          | 8. Overhang distance : L1, L2, L3 (m)                |
| 4. Travel time : t (s)                                 | 9. Length from center of guide to table end : L (m)  |
| 5. Cylinder operation direction : Vertical, horizontal | 10. Length of from table end to the load : A (m)     |

### STEP2 Static moment confirmation

Allowable moment may vary depending on installation attitude of load (M1/M2/M3 directions)  
Refer to the diagram below to calculate function moment.

● When installation attitude of load is only one way.  
Check if the calculated value is within the range of allowable moment (Table 1).

● If installation attitude of load is more than two directions (when combined moment).  
Divide the calculated values for each direction by allowable moment on (Table 1) to find moment ratio.  
Check if the total of ratio is less than 1.0.

$$\frac{M1}{M1max} + \frac{M2}{M2max} + \frac{M3}{M3max} \leq 1.0$$

Table 1 Allowable moment during traveling (N·m)

Bore size (mm)	M1	M2	M3
φ6	0.16	0.24	0.16
φ8	0.16	0.24	0.16
φ12	0.27	0.55	0.27
φ16	0.57	1.16	0.57

● Bending moment : M1  
M1(N·m) = 10 X m1(kg) X L1(m)

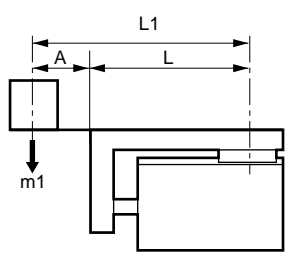

● Radial moment : M2  
M2(N·m) = 10 X m2(kg) X L2(m)

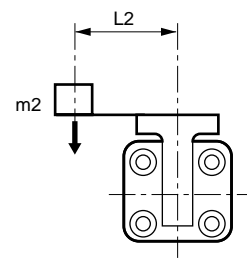

● Twist moment : M3  
M3(N·m) = 10 X m3(kg) X L3(m)

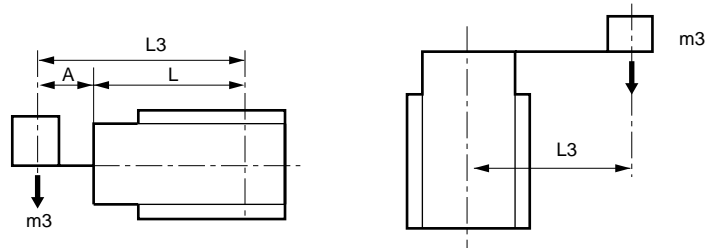

Bore size (mm)	Stroke length (m)					
	5	10	15	20	25	30
φ6	0.027	0.032	0.037	0.042	0.047	0.052
φ8	0.028	0.033	0.038	0.043	0.048	0.053
φ12	0.031	0.036	0.041	0.046	0.051	0.056
φ16	0.033	0.038	0.043	0.048	0.053	0.058



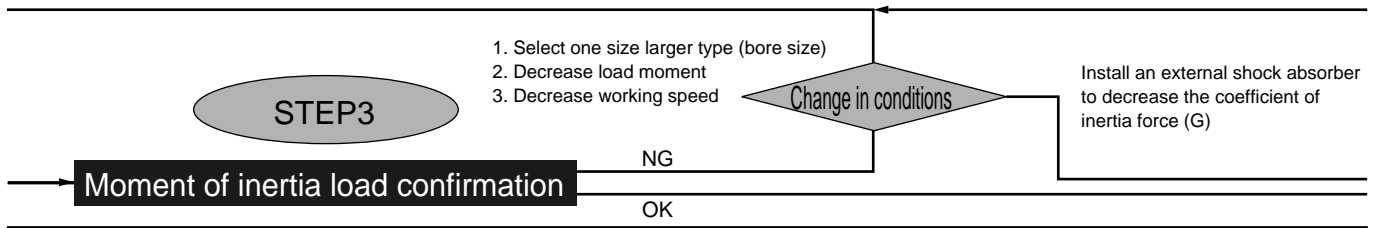

### STEP3 Moment of inertia load confirmation

Moment of inertia load may act depending on installation attitude of load (M1/M2/M3 directions). Refer to the diagram below to calculate moment of inertia load.

Moment of inertia load (M1'/M3') is found by load mass (m1, m2, m3), overhang distance (L1, L2, L3, L1', L3') and inertia force coefficient (G).

Find the inertia force coefficient (G) according to relations between inertia force coefficient and speed (Fig.1).

Check if the calculated value is within the range of allowable moment (Table 2).

Table 2 Allowable moment at inertia load applied (N·m)

Bore size (mm)	M1'	M2'	M3'
φ6	0.33	-	0.33
φ8	0.33	-	0.33
φ12	0.49	-	0.49
φ16	1.11	-	1.11

\*Inertia load is not applied to M2 direction.

#### ● Bending moment : M1

$$M1' = 10 \times m1 \times (L1 + G \times L1')$$

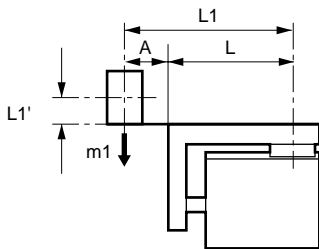

$$M1' = 10 \times m1 \times L1 \times (1 + G)$$

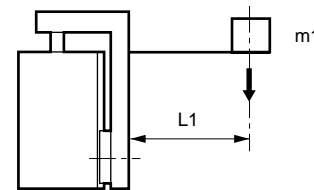

#### ● Twist moment : M3'

$$M3' = 10 \times m3 \times (L3 + G \times L3')$$

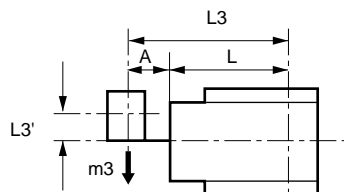

$$M3' = 10 \times m3 \times L3 \times (1 + G)$$

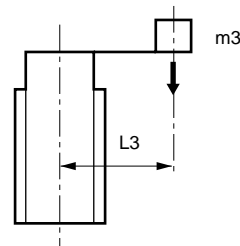

$$M3' = 10 \times m2 \times G \times L2$$

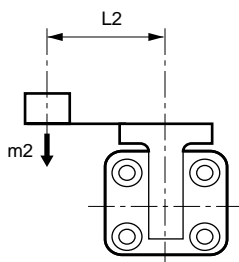
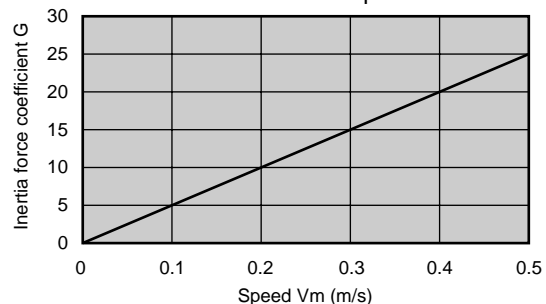

Fig. 1 Relations between inertia force coefficient and speed



(Note) Calculate speed Vm according to STEP4.

SCP\*2  
CMK2  
CMA2  
SCM  
SCG  
SCA2  
SCS  
CKV2  
CA/OV2  
SSD  
CAT  
MDC2  
MVC  
SMD2  
MSD\*  
FC\*  
STK  
ULK\*  
JSK/M2  
JSG  
JSC3  
USSD  
USC  
JSB3  
LMB  
STG  
STS/L  
LCS  
LCG  
LCM  
LCT  
LCY  
STR2  
UCA2  
HCM  
HCA  
SRL2  
SRG  
SRM  
SRT  
MRL2  
MRG2  
SM-25  
CAC3  
UCAC  
RCC2  
MFC  
SHC  
GLC

Ending

Small compact cylinder  
Space saving structure

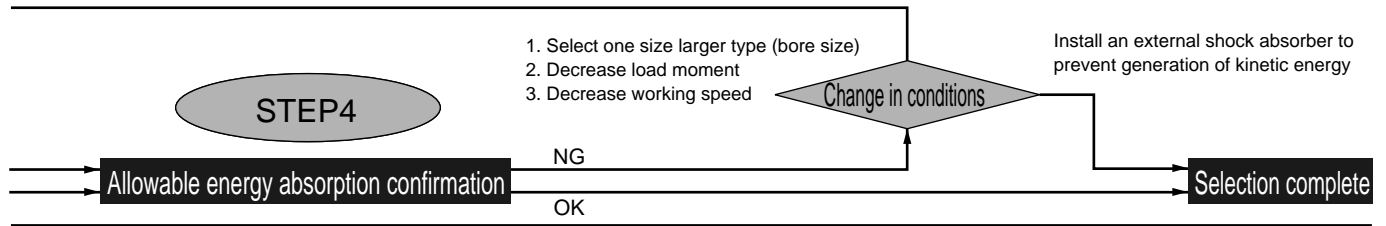

### STEP4 Allowable energy absorption confirmation

Find cylinder kinetic energy first.

$$E = \frac{1}{2} \times m \times V^2$$

$$V = \frac{St \times 10^{-3}}{t} \times (1 + 1.5 \times \frac{\alpha}{100})$$

$$\alpha = \frac{Fn}{F} \times 100$$

$$F = F0 \times \frac{\mu}{100}$$

- E : Kinetic energy (J)
- m : Weight of load (kg)
- V : Speed at stroke end (m/s)
- St : Stroke length (mm)
- t : Travel time (S)
- $\alpha$  : Load factor (%)
- Fn : Required thrust to move a work piece (N)
- F : Performing thrust (N)
- F0 : Theoretical thrust (refer to the table 4) (N)
- $\mu$  : Thrust efficiency (%)

Table 3 Required thrust (Fn)

Cylinder movement direction	Horizontal	Vertical
Thrust	$Fn = 0.2 \times 10 \times m$	$Fn = 1.2 \times 10 \times m$

Table 4 Theoretical thrust table (F0)

Bore size	Operating direction	Working pressure MPa										
		0.1	0.15	0.2	0.3	0.4	0.5	0.6	0.7	0.8	0.9	1.0
φ6	Push			6	8	11	14	17	20	23	25	28
	Pull			3	5	6	8	9	11	13	14	16
φ8	Push		8	10	15	20	25	30	35	40	45	50
	Pull		5	6	9	12	15	18	21	24	28	31
φ12	Push	11	17	23	34	45	57	68	79	90	102	113
	Pull	8	13	17	25	34	42	51	59	68	76	85
φ16	Push	20	30	40	60	80	100	121	141	161	181	201
	Pull	15	23	30	45	60	75	90	106	121	136	151

Fig. 2 Relations between thrust efficiency and pressure

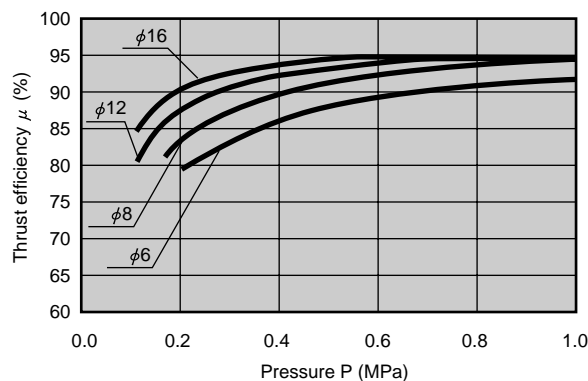

Check if kinetic energy (E) is not greater than allowable energy absorption (E0).

$$E \leq E0$$

Table 5 Allowable energy absorption (E0) (N·m)

Bore size (mm)	Allowable energy absorption E0 (J)
φ6	0.004
φ8	0.014
φ12	0.044
φ16	0.110

### Table tilt (reference value)

● Tilt at Point A when M1 applied.

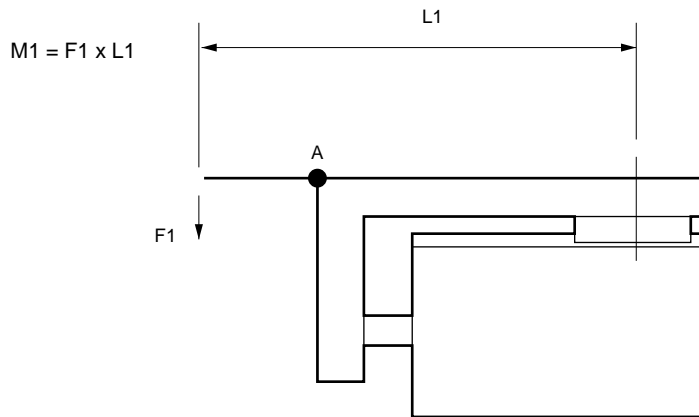

● MSDG-L-6

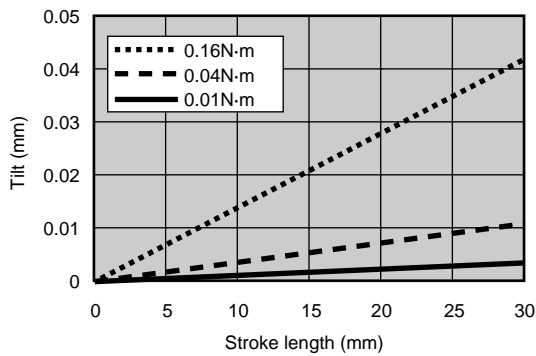

● MSDG-L-8

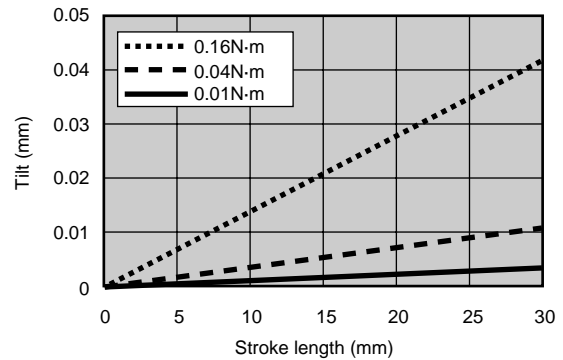

● MSDG-L-12

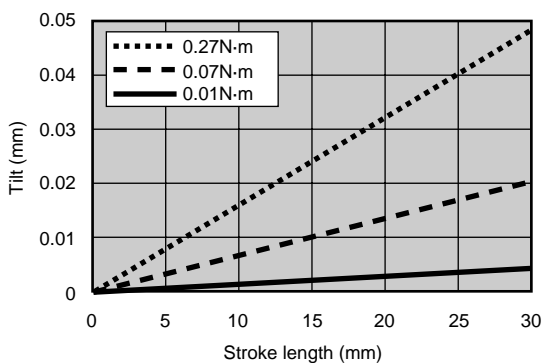

● MSDG-L-16

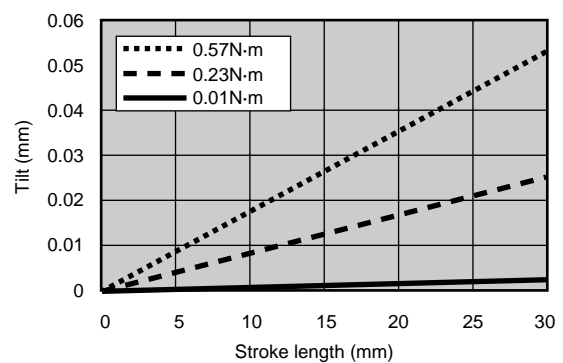

SCP*2
CMK2
CMA2
SCM
SCG
SCA2
SCS
CKV2
CA/OV2
SSD
CAT
MDC2
MVC
SMD2
<b>MSD*</b>
FC*
STK
ULK*
JSK/M2
JSG
JSC3
USSD
USC
JSB3
LMB
STG
STS/L
LCS
LCG
LCM
LCT
LCY
STR2
UCA2
HCM
HCA
SRL2
SRG
SRM
SRT
MRL2
MRG2
SM-25
CAC3
UCAC
RCC2
MFC
SHC
GLC

Ending

Small compact cylinder  
Space saving structure

## Table tilt (reference value)

● Tilt at Point A when M2 applied.

$$M2 = F2 \times L2$$

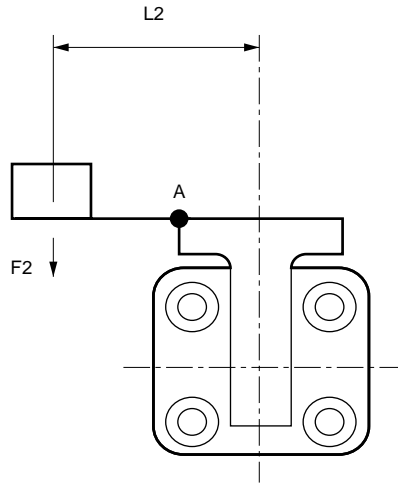

● MSDG-L-6

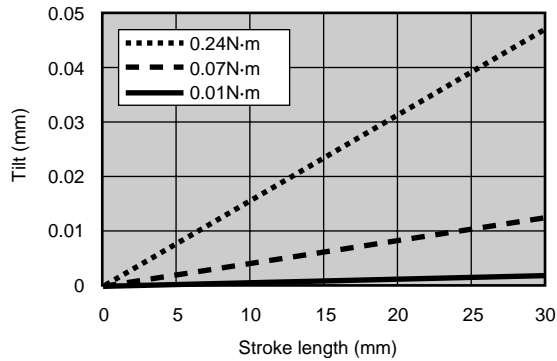

● MSDG-L-8

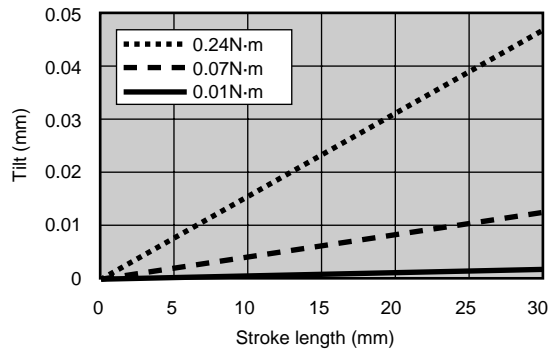

● MSDG-L-12

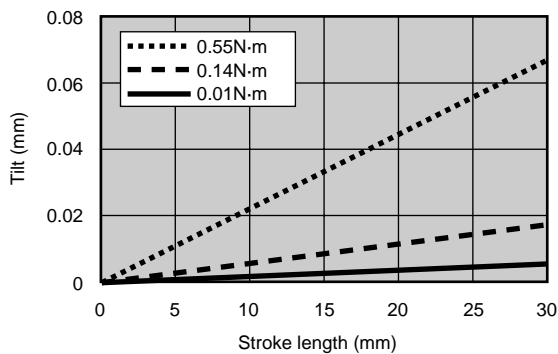

● MSDG-L-16

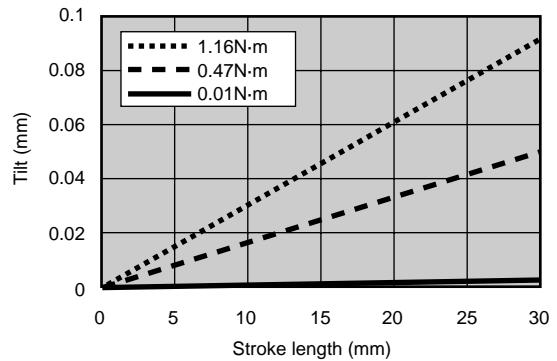

### Table tilt (reference value)

#### ● Tilt at Point A when M3 applied.

M3 = F3 x L3

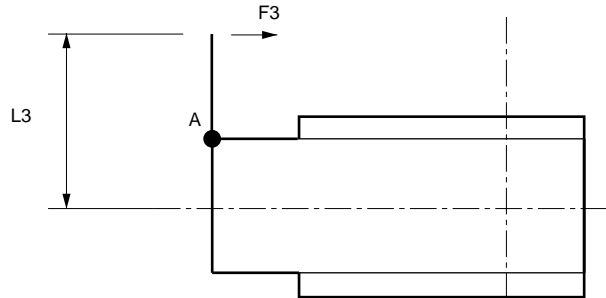

#### ● MSDG-L-6

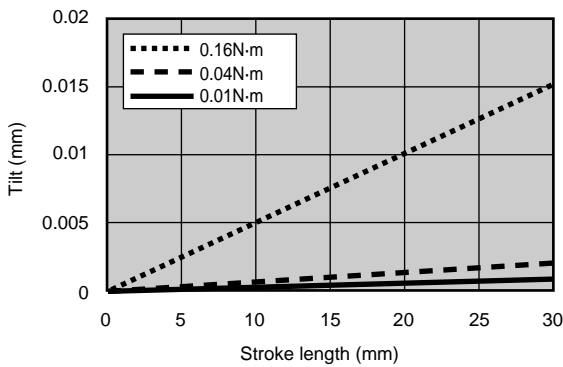

#### ● MSDG-L-8

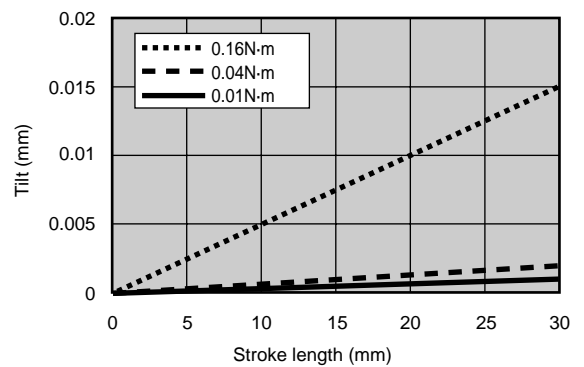

#### ● MSDG-L-12

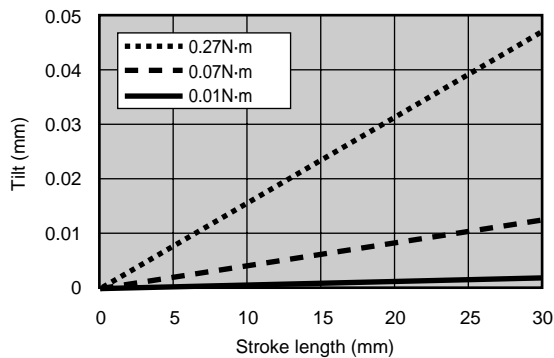

#### ● MSDG-L-16

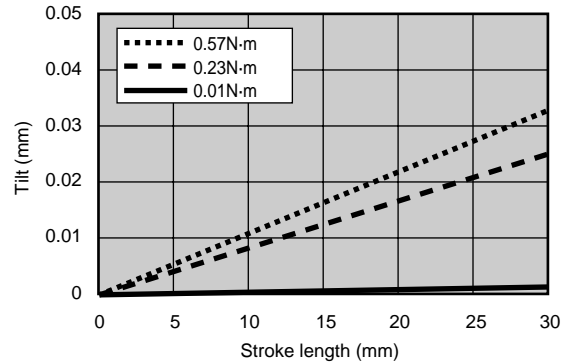

SCP*2
CMK2
CMA2
SCM
SCG
SCA2
SCS
CKV2
CA/OV2
SSD
CAT
MDC2
MVC
SMD2
<b>MSD*</b>
FC*
STK
ULK*
JSK/M2
JSG
JSC3
USSD
USC
JSB3
LMB
STG
STS/L
LCS
LCG
LCM
LCT
LCY
STR2
UCA2
HCM
HCA
SRL2
SRG
SRM
SRT
MRL2
MRG2
SM-25
CAC3
UCAC
RCC2
MFC
SHC
GLC

Ending

Small compact cylinder  
Space saving structure