

Diaphragm cylinder valve LAD/NAD Series

DIAPHRAGM CYLINDER VALVE

Able to handle various fluids from general fluids to deionized water

LAD Series



NAD Series

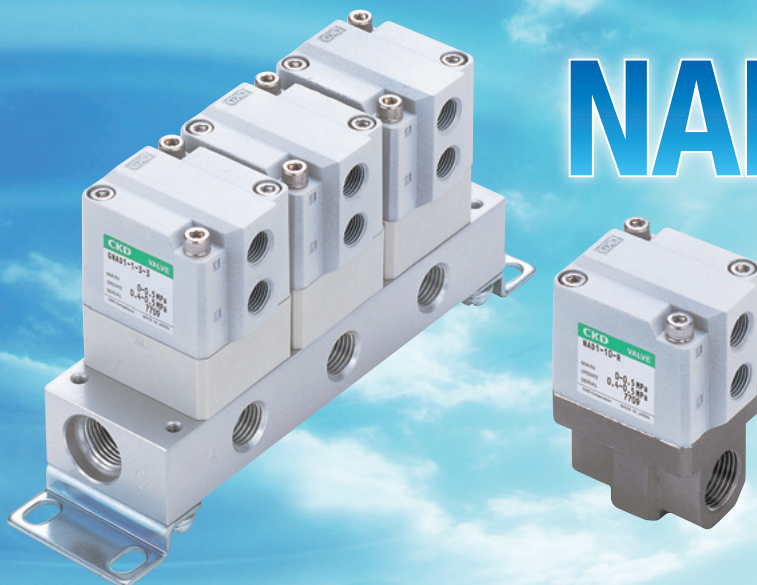

Grease free system.

Isolated construction with diaphragm that has completely separate flow path and sliding sections.

Prevents entry of oil and foreign matter.

Diaphragm cylinder valve LAD/NAD series.

Sliding section is separate from flow path

Diaphragm completely separates cylinder and flow path sections.

Flow path is grease free since there is no sliding piston rod.

Handles large flow rate despite its small size

Handles various fluids

Handles many types of fluids from general fluids to nitrogen gas and deionized water.

Export Trade Control Ordinance is not applicable

Any material combination is not applicable.

LAD Series



Light weight

Weight reduction achieved with plastic (PPS) actuator.

With flow adjustment (Option)

Space saving achieved with integrated flow control.



Selection of body material and sealant

Two body types available

PPS Body

Flow path section construction does not contain metal.

Stainless steel body

Handles metal piping requiring antistatics and is also perfect for controlling organic solvents.

Two sealant materials also available

PTFE Diaphragm

This grade also has proven results in the semiconductor industry.

EPDM Diaphragm

Highly durable for wider working pressure range.

LAD series variation

Series	Model no.	Orifice				Port size					Diaphragm material		Body material			
		ø7	ø8	ø12	ø20	Rc1/4	Rc3/8	Rc1/2	Rc3/4	Rc1	EPDM	PTFE	PPS	SCS13	SUS303	PP
LAD	LAD*-10A		●				●				●	●	●	●		
	LAD*-15A			●				●			●	●	●	●		
	LAD*-20A				●				●		●	●	●	●		
	LAD*-25A									●	●	●	●	●		

* Particles may be generated during construction as the connection is a screw connection.

Particles may also be generated during usage, especially if the diaphragm material is EPDM. Use caution regarding application and compatibility.

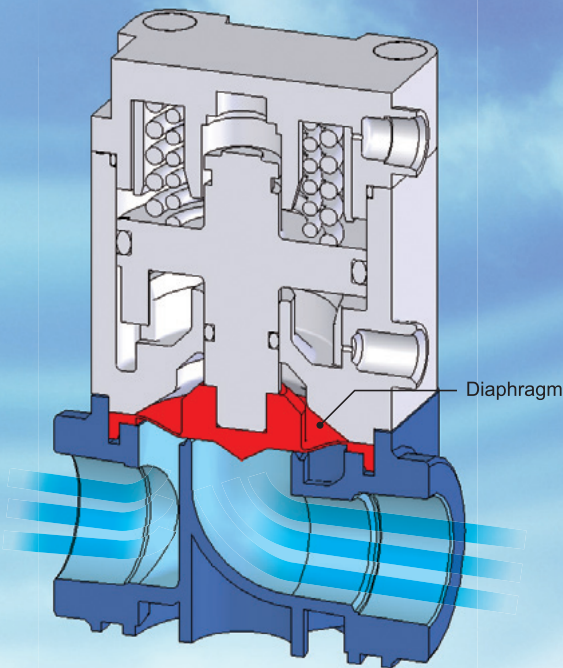

NAD Series



Manifold enables space saving

Different types of manifolds now available.
Achieves space saving for piping and reduces man-hours for piping.

Dimensions compatible with general purpose cylinder valve

Same dimensions as the general purpose cylinder valve NAB series. It can therefore be changed from the existing NAB series to a grease-free system by replacing only valve.



NAD series variation

Series	Model no.	Orifice				Port size					Diaphragm material		Body material				Sub plate	
		ø7	ø8	ø12	ø20	Rc1/4	Rc3/8	Rc1/2	Rc3/4	Rc1	EPDM	PTFE	PPS	SCS13	SUS303	PP	SUS303	A6063
NAD	NAD*-10	●					●				●			●				
	NAD*V-10	●					●				●			●				
GNAD	GNAD*-10	●				A port	C port				●			●	●	●	●	●
	GNAD*V-10	●				A port	C port				●			●	●	●	●	●

* Particles may be generated during construction as the connection is a screw type.
Particles may also be generated during usage, especially if the diaphragm material is EPDM. Use caution for application and compatibility.

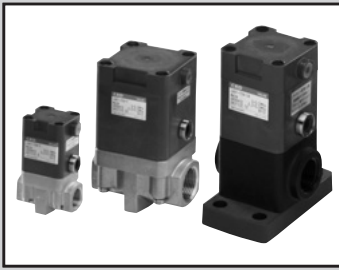

Diaphragm cylinder valve

LAD Series

- NC (Normally closed), NO (Normally open), double acting type
- Port size: Rc3/8, Rc1/2, Rc3/4, Rc1
- Working fluid: Pure water, water, air, N₂ gas



JIS symbol

- NC (normally closed)

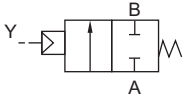

- NO (Normally open)

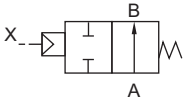

- Double acting type

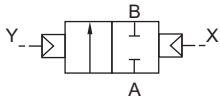

Common specifications (PTFE diaphragm)

Items	LAD1	LAD2	LAD3
Actuation	NC (Normally closed)	NO (Normally open)	Double acting type
Working fluid	Water, pure water, air, N ₂ gas, non-corrosive and non-penetrable fluids (Note 1)		
Fluid temperature °C	5 to 90 (Note 2)		
Withstanding pressure (water pressure) MPa	0.9		
Working pressure range (A → B) MPa	0 to 0.3		
Valve seat leakage cm ³ /min	0 (water pressure), 1 or less (air pressure)		
Back pressure MPa	0 to 0.1		
Ambient temperature °C	0 to 60		
Mounting attitude	Free		
Operation section	Pilot air pressure MPa	0.3 to 0.5	0.3 to 0.4
	Pilot port size	Rc1/8 (Note 3)	

Note 1: Check the compatibility between the material of each components and the working environment of the working fluid.

Not to be used with fluids with high acidity and penetrability.

Note 2: 5 to 100°C if the body material is stainless steel (SCS13).

Note 3: With stainless steel stiffening ring.

Individual specifications (PTFE diaphragm)

Items Model no.	Port size	Orifice mm	Cv flow factor	Frequency Times/Minute	Weight kg	
					PPS Body	SCS13 Body
LAD*-10A	Rc3/8	8	1.7	30 or less	0.15	0.3
LAD*-15A	Rc1/2	12	3.3	20 or less	0.28	0.6
LAD*-20A	Rc3/4	20	8.5	20 or less	0.55	1.1
LAD*-25A	Rc1	20	8.5	20 or less	0.60	1.2

Individual specifications (EPDM diaphragm)

Items	LAD1	LAD2	LAD3
Actuation	NC (Normally closed)	NO (Normally open)	Double acting type
Working fluid	Water, air, N ₂ gas, non-corrosive and non-penetrable fluids (Note 1)		
Fluid temperature °C	0 to 60 (No freezing)		
Withstanding pressure (water pressure) MPa	1.5 (Differs according to type chosen. Please refer to the pressure resistance in the individual specifications.)		
Working pressure range (A → B) MPa	0 to 0.5 (Differs according to type chosen. Please refer to the working pressure range in the individual specifications.)		
Valve seat leakage cm ³ /min	0 (water pressure), 0.12 or less (air pressure)		
Back pressure MPa	0 to 0.1		
Ambient temperature °C	0 to 60		
Mounting attitude	Free		
Operation section	Pilot air pressure MPa	0.3 to 0.5	0.3 to 0.4
	Pilot port size	Rc1/8 (Note 2)	

Note 1: Check the compatibility between the material of each components and the working environment of the working fluid.

Not to be used with fluids with high acidity and penetrability.

Note 2: With stainless steel stiffening ring.

Individual specifications (EPDM diaphragm)

Items Model no.	Port size	Withstanding pressure (water pressure) MPa	Working pressure range (A → B) MPa	Orifice mm	Cv flow factor	Frequency Times/Minute	Weight kg	
							PPS Body	SCS13 Body
LAD*-10A	Rc3/8	1.5	0.5	8	1.7	30 or less	0.15	0.3
LAD*-15A	Rc1/2	1.5	0.5	12	3.3	20 or less	0.28	0.6
LAD*-20A	Rc3/4	1.2	0.4	20	8.5	20 or less	0.55	1.1
LAD*-25A	Rc1	1.2	0.4	20	8.5	20 or less	0.60	1.2

How to order

LAD **1** - **15A** - **C** **B**

Model no.

a Actuation

b Port size

c Material combination

d Other options

Symbol	Description				
a Actuation					
1	NC (Normally closed)				
2	NO (Normally open)				
3	Double acting type				
b Port size Note3·4·5					
10A	Rc3/8	10G	G3/8	10N	NPT3/8
15A	Rc1/2	15G	G1/2	15N	NPT1/2
20A	Rc3/4	20G	G3/4	20N	NPT3/4
25A	Rc1	25G	G1	25N	NPT1
c Material combination					
	Body		Diaphragm		
P	PPS		EPDM		
C	PPS		PTFE		
R Note4	SCS13		EPDM		
F Note4	SCS13		PTFE		
d Other options					
Blank	No options				
1	With flow adjustment				
B	Mounting plate				

<Example of model number> LAD1-15A-CB

Model: Diaphragm structure cylinder valve LAD

- a** Actuation : NC (Normally closed)
- b** Port size : Rc1/2
- c** Material combination : Body PPS, Diaphragm PTFE
- d** Other options : Mounting plate

Note1: When adding both a regulator and a mounting plate, please indicate "1B".
 Note2: Contact CKD for valves supplied with an indicator.
 Note3: G thread and NPT thread are custom order.
 Note4: G thread and NPT thread can be selected with only R or F for **c**.
 Note5: Pilot connection port size is Rc1/8.

Internal structure and parts list

● PTFE Diaphragm

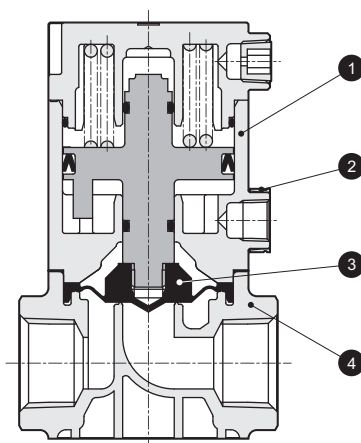

No.	Part name	Material	
1	Actuator assembly	PPS	Polyphenylene sulfide
		FKM	Fluoro rubber
2	Stiffening ring	SUS 304	Stainless steel
3	Diaphragm	PTFE	Polytetrafluoroethylene resin
4	Body	PPS	Polyphenylene sulfide
		(SCS13)	(stainless casting)

Items inside parentheses are optional

● EPDM Diaphragm

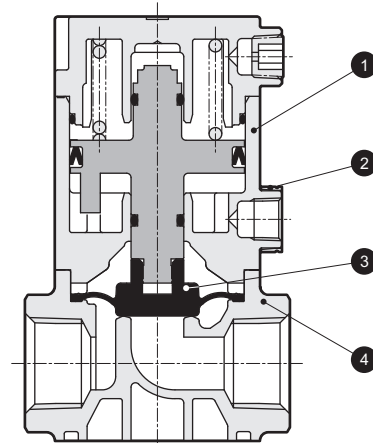

No.	Part name	Material	
1	Actuator assembly	PPS	Polyphenylene sulfide
		FKM	Fluoro rubber
2	Stiffening ring	SUS 304	Stainless steel
3	Diaphragm	EPDM, SUS303	Ethylene propylene diene rubber, Stainless steel
4	Body	PPS	Polyphenylene sulfide
		(SCS13)	(stainless casting)

Items inside parentheses are optional

Dimensions

● PPS Body

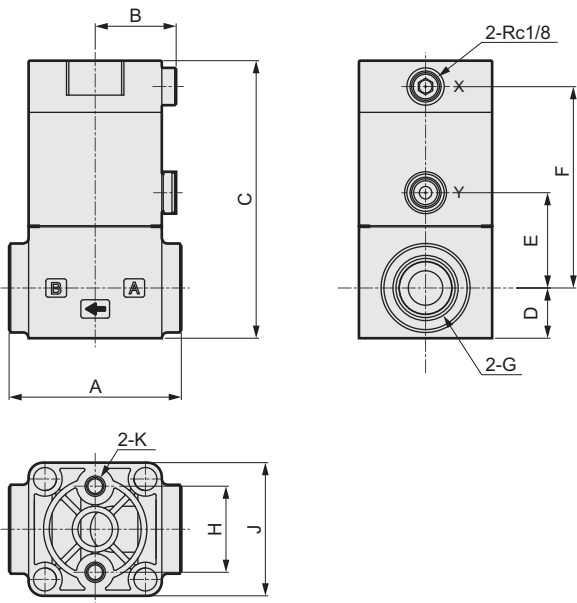

Model no.	A	B	C	D	E	F	G	H	J	K
LAD*-10A	47	23	77	14.5	25.5	55.5	Rc3/8	20	36	M5 Depth 7
LAD*-15A	60	28	96.5	17.5	33	70	Rc1/2	30	46.5	M6 Depth 8
LAD*-20A	75	35	114.5	22	40.5	83	Rc3/4	38	60	M6 Depth 10
LAD*-25A	85	35	121.5	25.5	44	86.5	Rc1	38	60	M6 Depth 10

● Stainless steel body

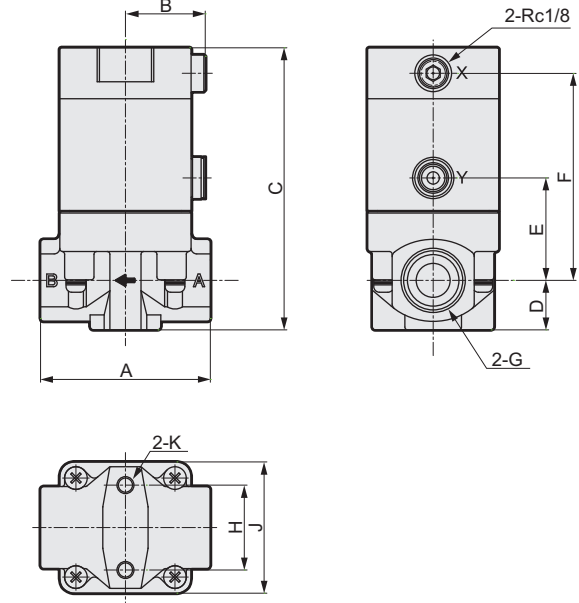

Model no.	A	B	C	D	E	F	G	H	J	K
LAD*-10A	47	23	80	14.5	28.5	58.5	Rc3/8	20	36	M5 Depth 7
LAD*-15A	60	28	99.5	17.5	36	73	Rc1/2	30	46.5	M6 Depth 8
LAD*-20A	75	35	117.5	22	43.5	86	Rc3/4	38	60	M6 Depth 10
LAD*-25A	85	35	121.5	25.5	44	86.5	Rc1	38	60	M6 Depth 10

Dimensions with options

● Valve rod (PPS Body)

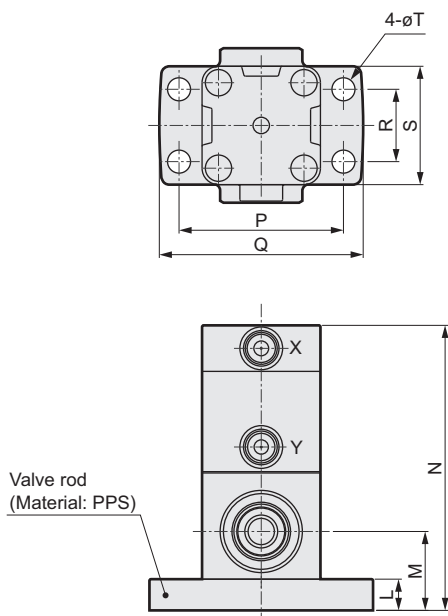

Model no.	L	M	N	P	Q	R	S	T
LAD*-10A	9.5	24	86.5	50	62	22	36	7
LAD*-15A	12.5	30	109	64	82	28	46.5	9
LAD*-20A	13	35	127.5	78	96	40	60	9
LAD*-25A	13	38.5	134.5	78	96	40	60	9

● Valve rod (Stainless steel body)

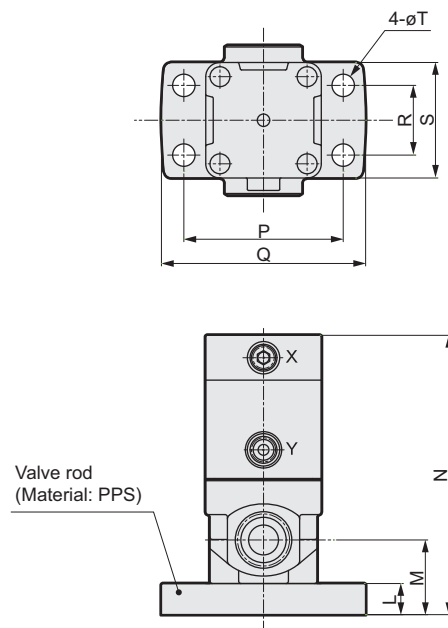

Model no.	L	M	N	P	Q	R	S	T
LAD*-10A	9.5	24	89.5	50	62	22	36	7
LAD*-15A	12.5	30	112	64	82	28	46.5	9
LAD*-20A	13	35	130.5	78	96	40	60	9
LAD*-25A	13	38.5	134.5	78	96	40	60	9

Dimensions with options

● With flow adjustment (PPS Body)

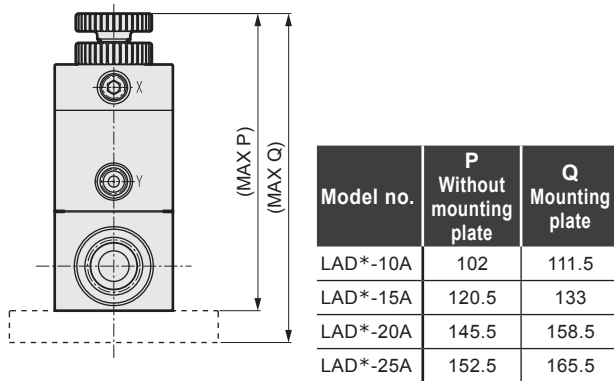

● With flow adjustment (Stainless steel body)

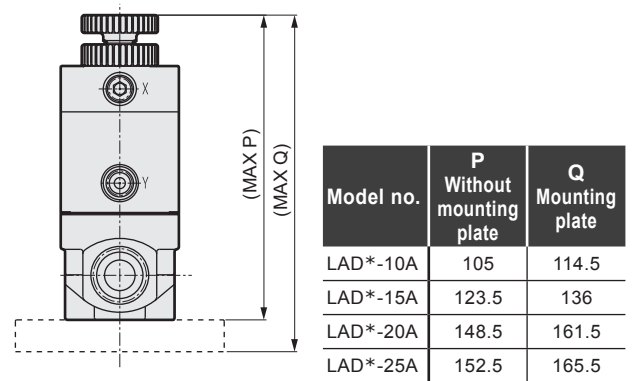

Dimensions/Flow characteristics

● With flow adjustment (water)

Number of rotations

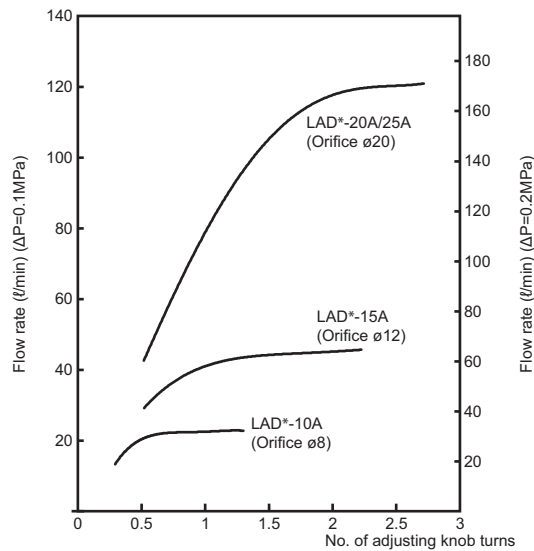

Note1: Set the adjusting dial as follows: for connection port 10A, open a 1/4 turn or more from the fully closed position; for all other port sizes, open more than a 1/2 turn. Using the product with a smaller opening than recommended may cause vibration or fluctuation in flow depending on the working conditions.

Product installation method (example)

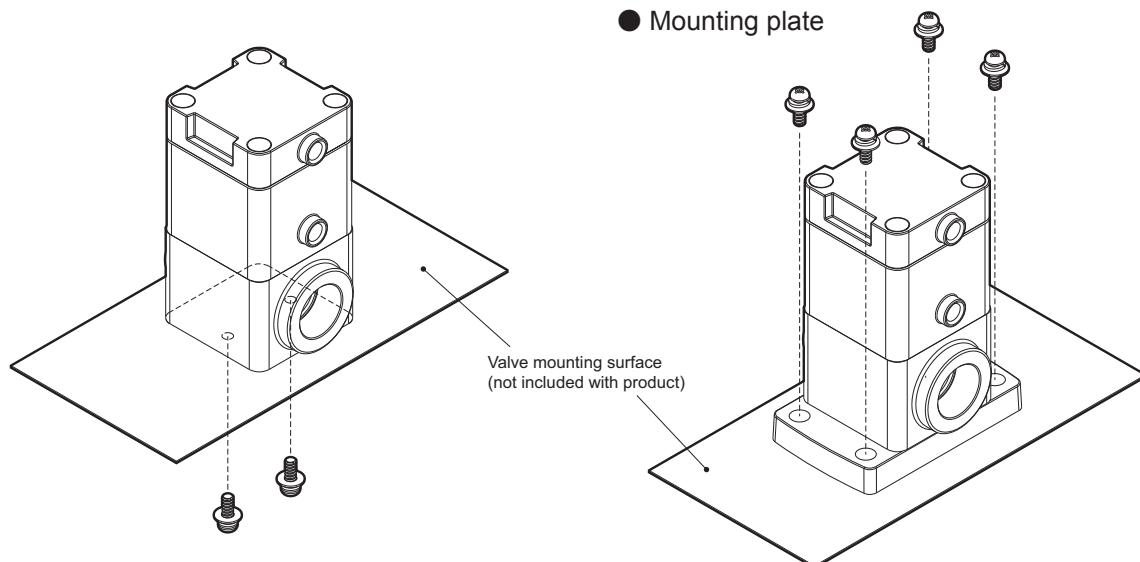

Note 1: Please use the recommended tightening torques (refer to the safety precautions).
 Note 2: Set screws are not included with the product.

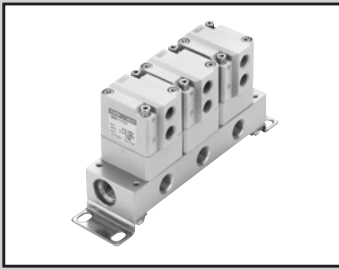

Diaphragm cylinder valve manifold

GNAD*/GNAD*V Series

- NC (Normally closed), NO (Normally open), double acting type
- Port size: Rc3/8
- Working fluid
 - GNAD* : Air, inert gas, water, non-corrosive liquids
 - GNAD*V : Low vacuum



JIS symbol

- Common supply type (C port pressurization)

NC (Normally closed)

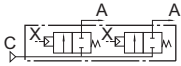

NO (Normally open)

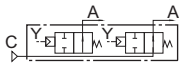

Double acting type

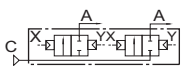

- Individual supply type (A port pressurization)

NC (Normally closed)

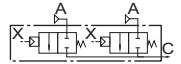

NO (Normally open)

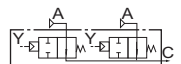

Double acting type

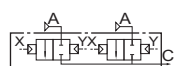

Specifications

Items	GNAD1-1/5	GNAD2-1/5	GNAD3-1/5	GNAD1V-1/5	GNAD2V-1/5	GNAD3V-1/5
Actuation	NC (Normally closed)	NO (Normally open)	Double acting type	NC (Normally closed)	NO (Normally open)	Double acting type
Working fluid	Air, inert gas, water, non-corrosive liquids			Low vacuum (air, water)		
Fluid viscosity mm ² /s	500 or less					
Working pressure range	0 to 0.5MPa (secondary pressure 0.4MPa or less)			1.3 × 10 ² to 5 × 10 ⁵ Pa (abs) (secondary pressure 4 × 10 ⁵ Pa (abs) or less)		
Pressure resistance (water) MPa	1.0					
Fluid temperature °C	-10 to 50 (no freezing)					
Ambient temperature °C	-10 to 50					
Valve seat leakage	0.12cm ³ /min or less (air pressure)			1.33 × 10 ⁻³ Pa•m ³ /sHe or less		
Orifice mm	7					
Cv flow factor	0.7					
C [dm ³ /(s•bar)]	3.4					
b	0.1			-		
Mounting attitude	Free					
Pilot air pressure MPa	0.4 to 0.5					
Pilot port size	Rc1/8					

Note 1: Effective sectional area S and sonic conductance C are converted as $S \approx 5.0 \times C$.

How to order

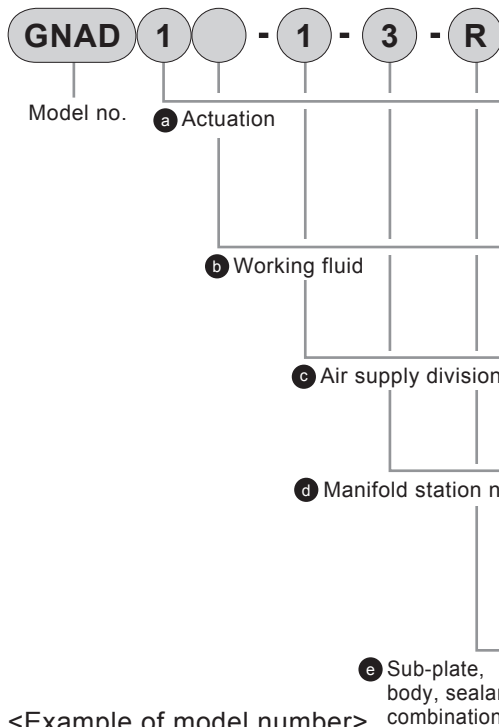

Symbol	Description
a Actuation	
1	NC (Normally closed)
2	NO (Normally open)
3	Double acting type
b Working fluid	
Blank	Air, inert gas, water
V	Low vacuum
c Air supply division	
1	Common supply type
5	Individual supply type
d Manifold station no.	
2 to 10	2 stations to 10 stations
0	Actuator only
e Sub-plate, body, sealant combination	
	Sub plate Body Seal
R	Stainless steel Stainless steel Ethylene-propylene rubber
8	Stainless steel Polypropylene Ethylene-propylene rubber
3	Aluminum Polypropylene Ethylene-propylene rubber

<Example of model number>

GNAD1-1-3-R

Model: GNAD

- a Actuation : NC (Normally closed)
- b Working fluid : Air, inert gas, water
- c Air supply division : Common supply type
- d Manifold station no. : 3 stations
- e Sub-plate, body, sealant combination : Sub plate-Stainless/ Stainless steel body/
Sealant - Ethylene-propylene rubber

Internal structure and parts list

● GNAD1

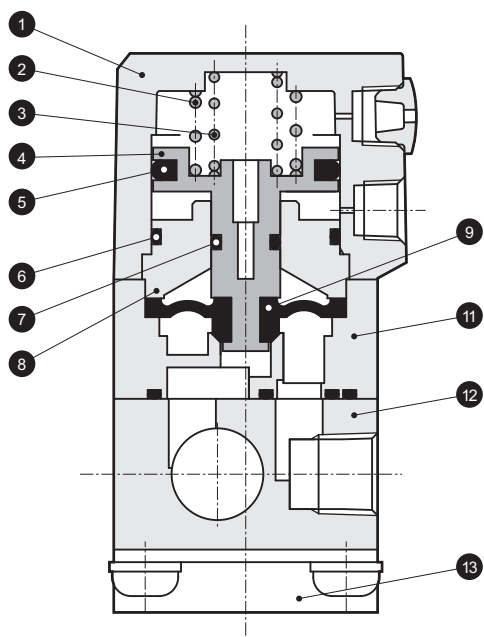

● GNAD1V

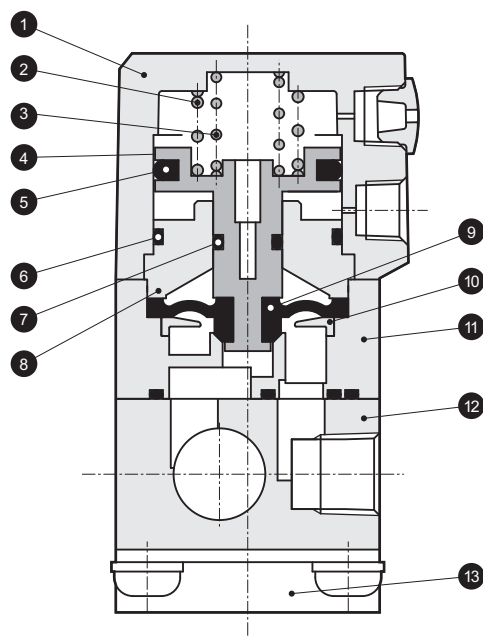

No.	Part name	Material	
1	Cylinder cover	ADC12	Aluminum die-casting
2	Spring	SWP	Piano wire
3			
4	Piston	PPS	Polyphenylene sulfide
5	PSD packing	NBR	Nitrile rubber
6	O ring	NBR	Nitrile rubber
7	O ring	FKM	Fluorine rubber
8	Adaptor	A5056	Aluminum
9	Diaphragm	EPDM	Ethylene-propylene rubber
10	Retainer	PP	Polypropylene
11	Body	PP (SUS303)	Polypropylene (Stainless steel)
12	Sub plate	SUS303 (A6063)	Stainless steel (Aluminum)
13	Mounting plate	SPC	Steel

GNAD*/GNAD*V Series

Dimensions: Actuator

● Common supply type GNAD1/2/3-1-0

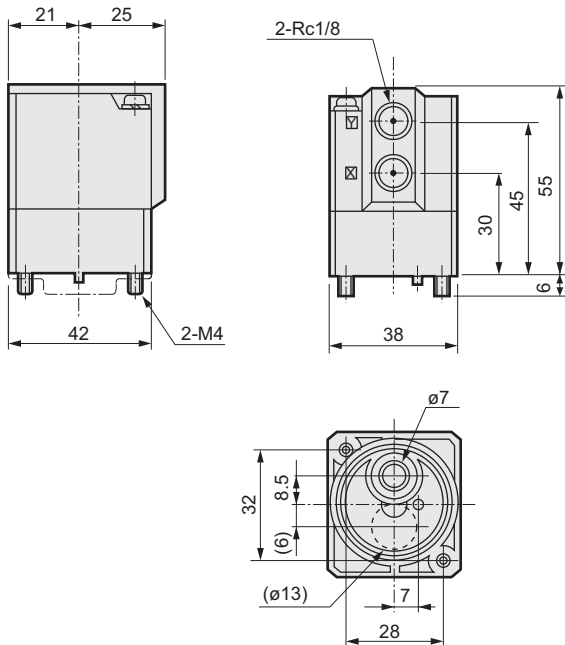

● Actuator installation method

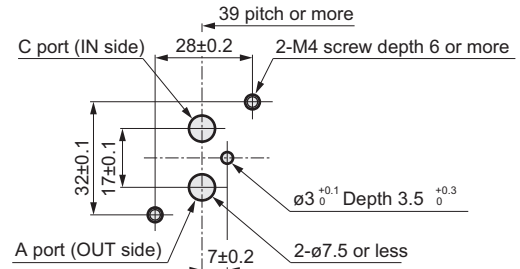

● Individual supply type GNAD1/2/3-5-0

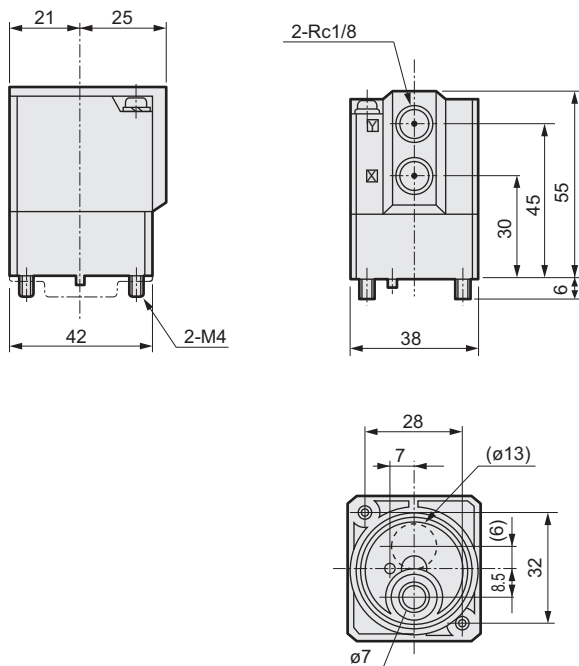

● Actuator installation method

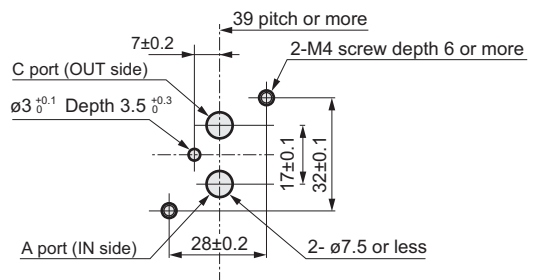

Note 1: Dimensions inside parentheses indicate dimensions for stainless steel option.

Note 2: Product will be shipped with a plate attached on the body's base for protection. Please remove this plate before use.

Dimensions: Manifold

● GNAD1/2/3-¹/₅ - 2~10

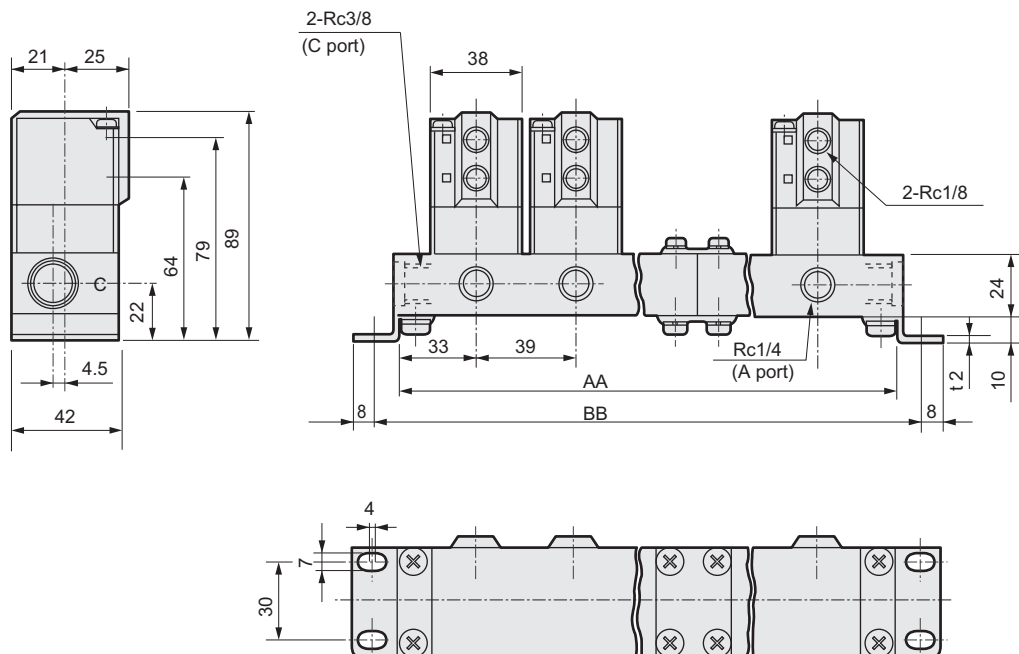

Sub-plate material	Stainless steel		Aluminum		Manifold Configuration*1	Sub-plate material	Stainless steel		Aluminum		Manifold Configuration*1
Station no.	AA	BB	AA	BB		Station no.	AA	BB	AA	BB	
2	106	122	105	121	2 stations × 1	7	329	345	327	343	5 stations + 2
3	145	161	144	160	3 stations × 1	8	368	384	366	382	5 stations + 3
4	212	228	210	226	2 stations × 2	9	435	451	432	448	3 stations × 3
5	223	239	222	238	5 stations × 1	10	446	462	444	460	5 stations × 2
6	290	306	288	304	3 stations × 2						

*1: Manifold has a consolidated structure based on 2, 3 or 5 stations.

*2: Contact CKD if using 11 stations or more.



Safety precautions

Always read this section before starting use.

When designing and manufacturing a device using CKD products, the manufacturer is obligated to check that device safety mechanism, pneumatic control circuit, or water control circuit and the system operated by electrical control that controls the devices is secured.

It is important to select, use, handle, and maintain the product appropriately to ensure that the CKD product is used safely.

Observe warnings and precautions to ensure device safety.

Check that device safety is ensured, and manufacture a safe device.

WARNING

- 1** This product is designed and manufactured as a general industrial machine part. It must be handled by an operator having sufficient knowledge and experience in handling.
- 2** Use this product in accordance of specifications.
This product must be used within its stated specifications. It must not be modified or machined. This product is intended for use as a general-purpose industrial device or part. It is not intended for use outdoors or for use under the following conditions or environment.
(Note that this product can be used when CKD is consulted prior to use and the customer consents to CKD product specifications. The customer must provide safety measures to avoid risks in the event of problems.)
 - ① Use for special applications including nuclear energy, railway, aircraft, marine vessel, vehicle, medicinal devices, devices or applications coming into contact with beverages or foodstuffs, amusement devices, emergency cutoff circuits, press machines, brake circuits, or safety devices or applications.
 - ② Use for applications where life or assets could be adversely affected, and special safety measures are required.
- 3** Observe corporate standards and regulations, etc., related to the safety of device design and control, etc.
ISO4414, JIS B 8370 (pneumatic system rules)
JFPS2008 (principles for pneumatic cylinder selection and use)
Including High Pressure Gas Maintenance Law, Occupational Safety and Sanitation Laws, other safety rules, body standards and regulations, etc.
- 4** Do not handle, pipe, or remove devices before confirming safety.
 - ① Inspect and service the machine and devices after confirming safety of the entire system related to this product.
 - ② Note that there may be hot or charged sections even after operation is stopped.
 - ③ When inspecting or servicing the device, turn off the energy source (air supply or water supply), and turn off power to the facility. Discharge any compressed air from the system, and pay enough attention to possible water leakage and leakage of electricity.
 - ④ When starting or restarting a machine or device that incorporates pneumatic components, make sure that the system safety, such as pop-out prevention measures, is secured.
- 5** Observe warnings and cautions on the pages below to prevent accidents.
 - The precautions are ranked as "DANGER", "WARNING" and "CAUTION" in this section.

 **DANGER:** When a dangerous situation may occur if handling is mistaken leading to fatal or serious injuries, or when there is a high degree of emergency to a warning.

 **WARNING:** When a dangerous situation may occur if handling is mistaken leading to fatal or serious injuries.

 **CAUTION:** When a dangerous situation may occur if handling is mistaken leading to minor injuries or physical damage.

Note that some items described as "CAUTION" may lead to serious results depending on the situation. In any case, important information that must be observed is explained.

Limited Warranty and Disclaimer

- 1** "Warranty Period" is one (1) year from the first delivery to the customer.
- 2** In case any defect attributable to CKD is found during Warranty Period, CKD shall, at its own discretion, repair the defect or replace the relevant product in whole or in part, according to its own judgment. In no event CKD shall never be liable for the costs in relation to and the damages resulting from the (de) installation of the product.
This Limited Warranty will not apply to:
 - (1) Product abuse/misuse contrary to conditions/environment recommended in its catalogs/specifications.
 - (2) Failure due to other causes.
 - (3) Use other than original design purposes.
 - (4) Third-party repair/modification.
 - (5) Failure due to causes not foreseeable with technology at the time of delivery.
 - (6) Failure attributable to force majeure.
- 3** IN NO EVENT SHALL CKD BE LIABLE FOR BUSINESS INTERRUPTIONS, LOSS OF PROFITS, PERSONAL INJURY, COSTS OF DELAY OR FOR ANY OTHER SPECIAL, INDIRECT, INCIDENTAL OR CONSEQUENTIAL LOSSES, COSTS OR DAMAGES.
- 4** IN NO EVENT SHALL CKD BE LIABLE FOR MERCHANTABILITY OR FITNESS FOR A PARTICULAR PURPOSE, notwithstanding any disclosure to CKD of the use to which the product is to be put.



Safety precautions

Always read this section before use.

Diaphragm structure cylinder valve LAD series

Design and selection

1. Confirmation of specifications

WARNING

- This product can not be used as an emergency shut off valve.
Valves in this catalog are not designed to ensure safety through an emergency shutoff amongst other things. When using in such a system, provide other measures to ensure safety.
- When using in such a system, provide other measures to ensure safety. The user is responsible for confirming the compatibility of the product specifications with their system before selecting and handling the product.
- Working fluid
The compatibility check list on page 14 provides basic information on compatibility. Refer to it to check whether the material of each component is compatible with the working fluid and working environment. Contact CKD before using a fluid not listed on the check list or a fluid which has been recently added (including those with different concentrations).
- Temperature of fluid
Use the product with in the specified fluid temperature range.
- Working pressure range
Use the product within the working pressure range specified in the catalog.
- Back pressure
Use the product with in the specified fluid temperature range. Use caution so that the allowable range is not exceeded due to wrap around from other lines and pressure head from raised pipes.
- Working environment
 - (1) Check compatibility of the material of each component with the working environment before using the product. (Do not use it in a corrosive or flammable environment.)
 - (2) Make sure that fluids do not adhere to the product body.

- (3) Use the product within the ambient temperature range.
- (4) Do not use the product in a place where it could shaken or knocked, in a heat source neighborhood, or outdoors.
- (5) Do not use in areas exposed to direct sunlight or ultraviolet rays.

2. Design

WARNING

- Take measures to prevent harm to operators or objects should this product fail.
- When using a fluid that may cause personal injury, place the valve where it can not be reached.
- Liquid ring
The opening and closing movement of the valve makes the diaphragm go up and down, changing the inner volume of the valve. Therefore, since the fluid is incompressible (liquid), operation with the fluid sealed within the valve (liquid ring) places an abnormal pressure on the valve. In such cases, install a relief valve on the primary or secondary side of the valve to avoid a liquid ring circuit.
- Sufficient maintenance space
Ensure sufficient space for maintenance and inspection.
- When using RC screws, leakage may occur from the screw-in area due to the heat cycle. If using under with an RC screw, select the integrated type fitting from the air-operated valve for chemical fluid ("AMD series").

CAUTION

- Particles may be generated during construction as the connection is a screw connection. Particles may be generated during usage, especially if the diaphragm material is EPDM. Use caution regarding application and compatibility.

Installation & adjustment

1. Installation

WARNING

- Incorrect installation and piping cause product problems and may cause problems in the user's system, resulting in death or serious injury. The user is responsible for ensuring that the system is operated by someone who has read the instruction manual carefully and or who has read the entire instruction manual and understands the safety precautions concerning the system, the fluid characteristics, compatibility of the fluid and the related products.

CAUTION

- After installing, check for leaks from pipes, and check that the product has been correctly installed.

2. Piping

WARNING

- For the body's A and B ports, use plastic fittings or piping material that conform to JIS0203 piping taper screw (if body material is PPS).

- Observe the valid thread length for piping. Chamfer the end of the screw a half-pitch. Chamfering of nozzle.
- Always flush the piping before installing the valve. Dirt or foreign matter in fluid may prevent the valve from functioning correctly. If dirt or foreign matter may come inside, install a filter on the primary side of the valve in a position suitable for the circuit used.
- An arrow is displayed on the body side. Make sure to pipe so that fluid flows in the direction of the arrow.
- Pipe the product so that pipe tension, compression and bending, etc., are not applied to the valve body.
- For NC and NO types, ports on which control pressure is not placed are released in to the atmosphere. If direct intake and emission of air is not desirable due to a difficult working environment or dirt, release the set screw and do piping work so that air is taken in and emitted at a proper location.
- Select the solenoid valve for the drive connected to the drive section so that it matches specifications and application.
- If excessive sealant (tape, gel) is applied when piping, it could enter the product and cause operation faults.
- When applying or wrapping sealant on piping material, apply it or wind it from the pipe end along the screw and leave 1.5 to 2 threads uncovered.
- Check that stress, such as bending, tension, or compression, is not applied to the valve when connecting main pipes. Position and support pipes so that the weight of the pipes is not exerted on the weight of the pipe on valves.

- When installing a valve, do not support it by the fitting only, but fasten the mounting plate and the equipment.
- When controlling fluid in a tank, pipe slightly above the bottom of the tank.
- Piping
Refer to the table below for the A and B port's piping tightening torque. Conduct piping by securing the body so that there is no bending, tension, compression, etc. on the actuator assembly. Over tightening can cause product damage.

Port size	Recommended tightening torque (N·m)	
	If body material is resin	If body material is metal
10A	1.0 to 1.5	22 to 24
15A	2.0 to 2.5	28 to 30
20A	2.5 to 3.0	31 to 33
25A	3.0 to 4.0	36 to 38

- When conducting piping for the LAD series, use caution with regards to the supply port on the pilot operation side.

Model no.	Pilot operation supply port
LAD1	Y
LAD2	X
LAD3	X and Y

- Installation
Refer to the table below for the correct tightening torque for installation using the set screws on the resin body side.
Over tightening can cause product damage.

Port size	Screw size	Recommended tightening torque (N·m)
10A	M5	0.8 to 1.0
15A	M6	1.3 to 1.5
20A	M6	1.3 to 1.5
25A	M6	1.3 to 1.5

During use and maintenance

1. Before use of product

WARNING

- Use within the maximum service pressure and maximum working pressure range.

CAUTION

- The compatibility check list on page 14 provides basic information on compatibility. Refer to it to check whether the material of each component is compatible with the working fluid and working environment. Contact CKD before using a fluid not listed on the check list or a fluid which has been recently added (including those with different concentrations).
 - When using fluids containing a surface acting agent or highly permeable fluids, the fluid could permeate the part.
Conduct regular inspections, and in the event that an abnormality is found, take action such as replacing the damaged part.
- If diaphragm material is PTFE, gases such as N₂ and air may cause a maximum of 1cm³/min valve seat leakage (of air pressure).
- It should be noted that sudden changes in fluid temperature may distort the valve seat resulting in valve seat leakage (if body material is PPS).
- For control air, use air or inert gas that has

passed through a filter with a filtration rating of 5 μm or more.

- Do not over-clip the adjusting knob for flow control or bypass control.
- Do not step on valves, etc., or place heavy objects on them.
- If the product has not been used for a long period of time, carry out a trial operation before use.
- If leaving a valve with EPDM diaphragm material and N.O. (normally open) actuation closed over a long period, return may become slower or it may stop working due to the rubber solidifying. In such a case, return by removing the Y port's set screws and increasing the operating pressure.
- There occurs turbulent flow on the secondary side of the valve.
When you place, a device such as a flow meter, that requires the flow to be laminar, on the secondary side of the valve, place it some distance away from the valve in a position where the device is not affected by turbulent flow.
- This product must not be disassembled by the user. Disassembly is dangerous since some products have high load springs.
- Make sure that fluids do not adhere to the product body.

- If the product is with flow adjustment, set the adjustment dial to the specified number of rotations or more, in the open direction from the fully closed position. Using the product with a smaller opening may cause vibration or fluctuation in Flow depending on the working conditions. flow fluctuation may be caused by fluid temperature fluctuation, depending on the conditions of use
- Water-hammer or vibration may occur depending on media pressure. Most cases will be improved by using the flow control valve to adjust the open/close speed. If the situation does still not improve, check the media pressure and piping conditions.

2. Maintenance & Inspection

DANGER

- When replacing a valve, evacuate enough of the fluid inside using pure water or air beforehand so that the remaining fluid will not affect devices and people in the vicinity. Although the top of the diaphragm (on the cylinder side) is not a wet area, the area is a fluid atmosphere due to gas permeation from the thin film section. For safety reasons observe the following precautions when handling it.
 - (1) A small amount of permeated gas will be discharged from the bleed hole on the cylinder side as a result of the valve's operation.
 - (2) Before touching the valve, make sure to read the working fluid's material safety data sheet (MSDS); and, if necessary, make sure to use the required protective equipment/clothing.

- A valve that has been used for chemical liquid may have a chemical liquid atmosphere remaining between its actuator and diaphragm. This product must not be disassembled by the user. Contact CKD or a distributor when disassembling is required.
- To ensure optimum operation of the valve, conduct the following regular inspection once or twice a year.
 - (1) Check leakage outside the valve
 - (2) Check leakage from the port screw section
 - (3) Check for loosened and detached tubes in the operating air's piping

WARNING

- Read instructions and precautions supplied with the product before use or maintenance.
- Make sure to remove the operating air and fluid before maintenance.
- When conducting maintenance or an inspection, read the material safety data sheet (MSDS) of the chemical liquid used and wear the required protective clothing.

CAUTION

- When replacing a product use a product of the same model number. Some products have the same external appearance but different specifications.
- Store any unused products away from direct sunlight and the temperature is not high. When handling the product, do not knock or damage it by throwing, dropping, or catching it.

Compatibility check list of the product and working fluid

The check list has been created based on the past evaluations and experiences, but does not ensure a performance.

When using this regulator for chemicals, the user is responsible for confirming compatibility with the working fluid and product materials. OR the compatibility of the working fluid with product materials. A person with experience of working with chemicals should refer to the table below to confirm compatibility. Wetted parts and the product components could be affected by the permeated gas, and this could result in leaks from products, misoperation and similar problems.

Material combination symbol		P	C	R	F
Material	Body	PPS	PPS	SCS13	SCS13
	Diaphragm	EPDM	PTFE	EPDM	PTFE
Pure water		○	○	○	○
Sulfuric acid		×	×	×	×
Hydrochloric acid (5% or less)		○	○	×	×
Nitric acid		×	×	×	×
Hydrogen peroxide		×	×	×	×
Ozone		×	×	×	×
Sodium hydroxide (30% or less)		○	○	○	○
Aqueous ammonia		△Note 3	△Note 3	△Note 3	△Note 3
Acetone		○	△Note 3	○	△Note 3
Isopropyl alcohol		○	○	○	○
Thinner		×	△Note 3	×	△Note 3
Air, N ₂ gas		○	○	○	○

○: Usable, △: Can be used depending on conditions, ×: Not available
Contact CKD regarding fluids not mentioned above.

Note1: Some of the compatibility data was created based on documents provided by the material manufacturer. It is to be used as a reference and is not a guarantee for the product.

Note2: For fluids with high penetrability, a very small leak may occur along the cast cavity of screw sections or the stainless steel (SCS13).

Diaphragm structure cylinder valve NAD series

Design & selection

1. Working fluid

⚠ WARNING

■ Working media

- (1) Do not use this product for any other fluids other than those included in the catalog specifications.
- (2) Before use, make sure to confirm the compatibility of the product with the working fluid in the working fluid check list (General Purpose Valves (Catalog No. CB-03-1SA)).

⚠ CAUTION

■ External pilot air

- (1) Drainage measures: Compressed air contains high levels of drainage (water, oxidized oil, tar, foreign matter) that may reduce pneumatic component reliability. Drainage passes through the inlet pipe and accumulates in the tank. Improve air quality by dehumidifying with an after cooler or dryer, removing foreign matter with a filter, and removing tar with a tar removal filter, etc.
- (2) Oil free - This series is oil free. Do not use oil or lubrication.
- (3) Filter - Use filters with filter elements of 5µm or less.

2. Working environment

⚠ WARNING

- If there are high levels of dust in the area, provide protection by installing a silencer or an elbow connector facing downward onto the exhaust port so that dust does not enter.
- Take appropriate safeguards when using this product in places where water contact could occur.

⚠ CAUTION

- Particles may be generated during construction as the connection is a screw connection. As the diaphragm material is EPDM, particles may be generated during usage. Use caution regarding application and compatibility.

Installation & adjustment

1. Piping

⚠ CAUTION

- When conducting piping for the GNAD series, use caution with regards to the supply port on the pilot operation side.

Model no.	Pilot operation supply port
GNAD1/GNAD1V	X
GNAD2/GNAD2V	Y
GNAD3/GNAD3V	X and Y

- When conducting piping for the LAD series, use caution with regards to the supply port on the pilot operation side.

Model no.	Body side supply port	Pilot operation supply port
NAD1-10/NAD1V-10	A	X
NAD2-10/NAD2V-10	A	Y
NAD3-10/NAD3V-10	A	X and Y

Note 1) On the NAD $\frac{1}{3}$ V body side supply port, connect the chamber (vacuum holding side) to the A port.

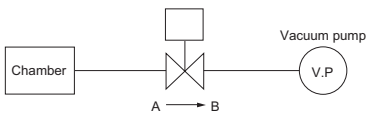

However, make sure the pressurized side uses the A port when using for vacuum breaks, etc.

- If a manifold is used on the SAB Series operation valve, exhaust pressure from other

valves could be led in and cause malfunctions such as momentary opening of the SAB. When using a manifold, use a valve with a built-in "check valve".

A check valve is built into CKD pilot 3 or 5 port valve 4G Series.

Example of pneumatics system that may cause malfunction

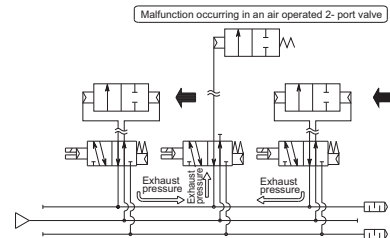

Pneumatics system based on 4G series

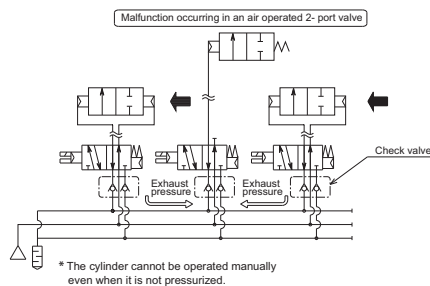

During use & maintenance

1. Maintenance & Inspection

⚠ CAUTION

■ Pilot air pressure

Use pilot air pressure within the specifications. For NO type and double acting types, seal defects will occur if using pilot pressure below the specified range. If the pilot air cannot be controlled, we recommend that you select an NC model.

2. Disassembly

⚠ CAUTION

- Disassembly of this valve is prohibited. Oil resistant properties of the fluid contact area may be lost if disassembled.

MEMO

Related products

3/4 port pilot operated valve MN3E/MN4E series

■ Greatly reduced installation space

In addition to the MN3/4E0 series which has a valve block width of 10 mm, MN3/4E00 is now available with a valve block width of 7 mm and manifold pitch of 7 mm. The 7 mm pitch and the more compact manifold contributes toward the downsizing and high integration performance of the device.

■ High performance

12 ms high-speed response is equal on A and B ports.
(CKD data value using type with two built-in 3 port valves)

■ Ease of use

Fitting usability is improved to match the downsized valve.
A variety of wire connections including 32-point serial transmission is available.

■ Environment/Safety

Eco-friendly wiring is used for internal wiring.
Measures to prevent the valve from malfunctioning have been incorporated.

Catalog No. CC-945A

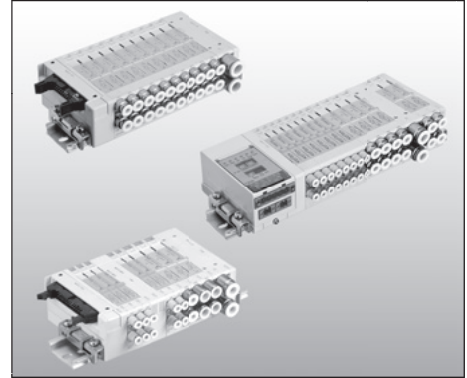

3/4/5 port pilot operated valve 4GA/4GB/MN4GA/MN4GB series

■ Cylinders of up to $\varnothing 100$ can be driven with valve widths of 10 mm, 15 mm and 18 mm

NEW 3/4/5-port reduced wiring valve with safety function.

■ Reinforced safety through detailed handling

A protective cover is provided as standard for all manual overrides, check valves are integrated, and a filter is provided for any air supplying port as standard.

■ Reliability has been improved

Service life of over 60 million times, response time of 12 ms \pm 2 ms, and low power of 0.6 W.

■ Usability has been improved

Same wiring connectors for upward and sideways, upward and sideways rotation of reduced wiring connectors, manual overrides don't require tools

■ Many variations are provided

Discrete parts, metal-based manifolds, block manifolds, individuals, reduced wiring

Catalog No. CB-023SA

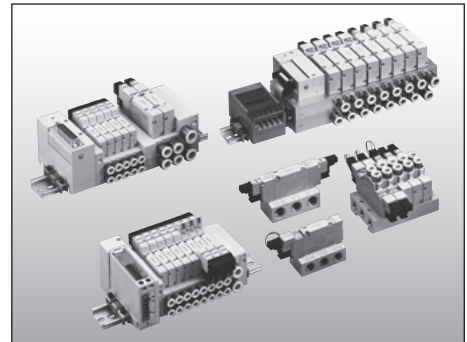

New joint GW/GWJ Series

■ Flow volume utilizing the entire bore size is possible

■ White body that comfortably fits your work space. Heat resistant resin is standard

■ V-shaped packaging used to seal tubes and fittings. Can be applied with little effort and seals completely

■ Outer dimensions of applicable tubes range from $\varnothing 3.2$ - $\varnothing 12$, there is a great variety to choose from

Catalog No. CB-024SA

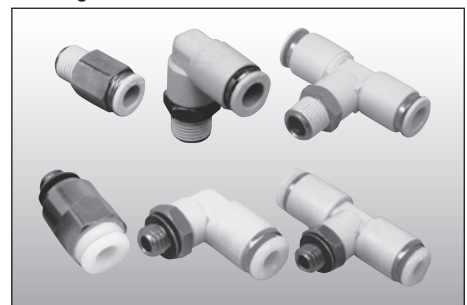

Related products

Air-Operated Valve for Chemical Liquids AMD 3*3/AMD 4*3 series

All-in-One Models Supporting Various Specifications

- Sizes: 1/4", 3/8", 1/2", 3/4", 1 inch
- Handles many types of chemical liquids
- Working pressure 0.5MPa
- Working fluid temperature 120°C
- Indicator comes as standard and optional sensor is available (excludes 1/4")
- Handles manifolds and cutting

Catalog No. CC-1015A

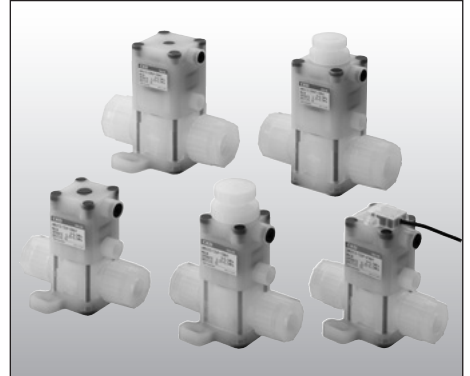

Water hammerless valve AMD*1L Series

The water hammerless valve has been designed to prevent as much vibration as possible so that the equipment is precise and durable. To be used in equipment in facilities that use clean deionized water for the manufacturing of LCDs, solar batteries, etc.

- The entire series is equipped with a water-hammer reduction function
- Series with wide variation (union fittings 15A to 50A)
- Fittings are PVC union fittings
- Wide optional variation
- Wide optional variation (With flow adjustment, bypass, flow adjustment/bypass)
- Export Trade Control Ordinance is not applicable

Catalog No. CC-816 (Jpn.)



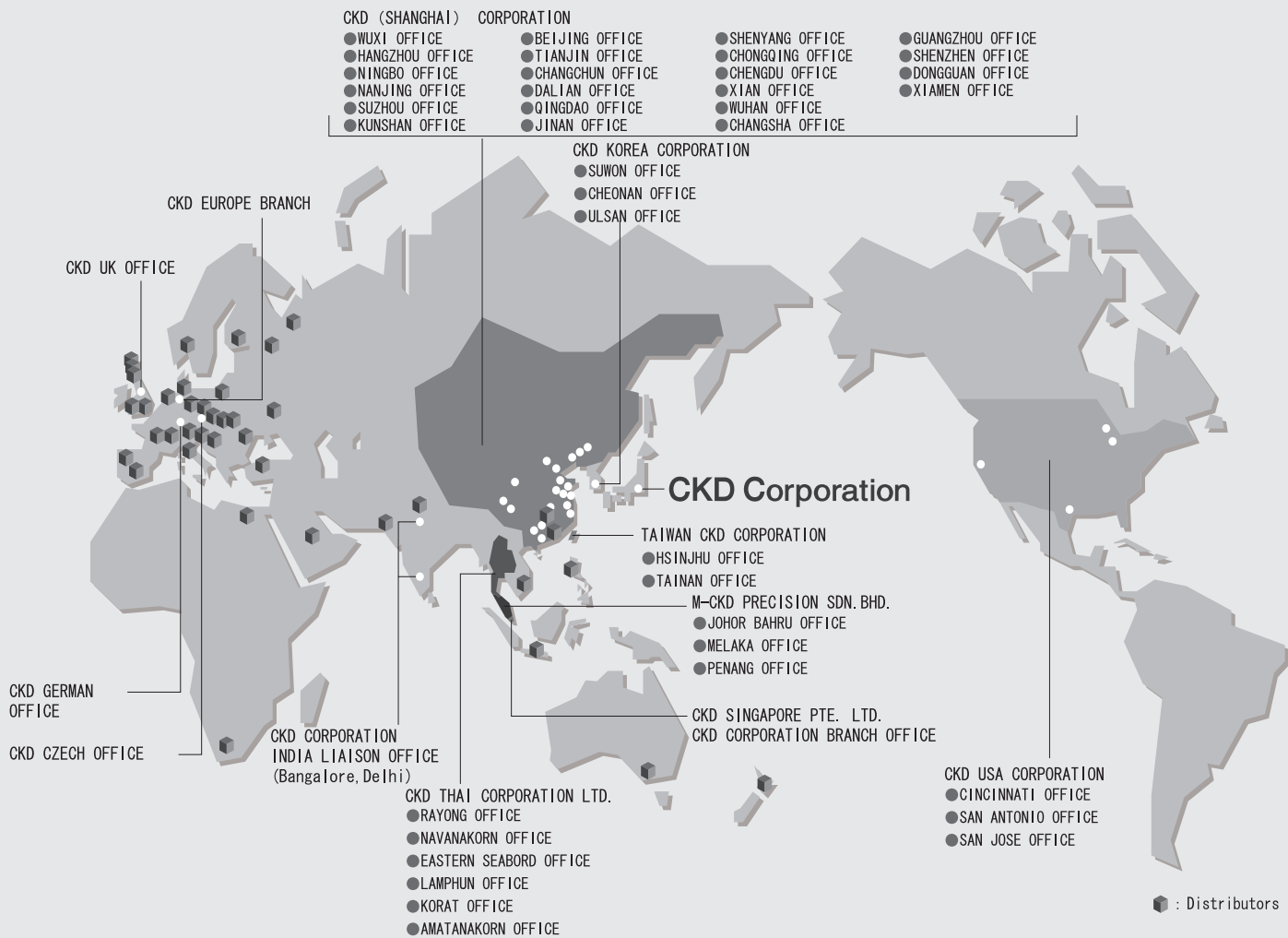

CKD Corporation

Website <http://www.ckd.co.jp/>

□ OVERSEAS SALES ADMINISTRATION DPT.
SALES AND MARKETING DIV. 2-250 Uji Komaki, Aichi 485-8551, Japan
□ PHONE +81-(0)568-74-1338 FAX +81-(0)568-77-3461

U. S. A.

CKD USA CORPORATION

● HEADQUARTERS
4080 Winnetka Avenue, Rolling Meadows, IL 60008 USA
PHONE +1-847-368-0539 FAX +1-847-788-0575

EUROPE

CKD EUROPE BRANCH

De Fruittuinen 28 Hoofddorp 2132NZ The Netherlands
PHONE +31-(0)23-5541490 FAX +31-(0)23-5541491

Malaysia

M-CKD PRECISION SDN. BHD.

● HEADQUARTERS
Lot No.6, Jalan Modal 23/2, Seksyen 23, Kawasan, MIEL,
Fasa 8, 40300 Shah Alam, Selangor Darul Ehsan, Malaysia
PHONE +60-(0)3-5541-1468 FAX +60-(0)3-5541-1533

Thailand

CKD THAI CORPORATION LTD.

● SALES HEADQUARTERS-BANGKOK OFFICE
Suwan Tower, 14/1 Soi Saladaeng 1, North Sathorn Rd., Bangrak,
Bangkok 10500 Thailand
PHONE +66-(0)2-267-6300 FAX +66-(0)2-267-6305

Singapore

CKD SINGAPORE PTE. LTD.

No. 33 Tannery Lane #04-01 Hoesteel Industrial Building Singapore 347789
PHONE +65-67442623 FAX +65-67442486

CKD CORPORATION BRANCH OFFICE

No. 33 Tannery Lane #04-01 Hoesteel Industrial Building Singapore 347789
PHONE +65-67447260 FAX +65-68421022

Taiwan

TAIWAN CKD CORPORATION

16F-3, No. 109, Sec. 1 Jhongshan RD., Shinjhuang Dist., New Taipei City,
24250, Taiwan (R. O. C)
PHONE +886-(0)2-8522-8198 FAX +886-(0)2-8522-8128

China

CKD (SHANGHAI) CORPORATION

● SALES HEADQUARTERS / SHANGHAI OFFICE
Room 601, Yuan Zhong Scientific Reseach Building,
1905 Hongmei Road, Shanghai, 200233, China
PHONE +86-(0)21-61911888 FAX +86-(0)21-60905356

Korea

CKD KOREA CORPORATION

● HEADQUARTERS
3rd FL., Sam Young B/D, 371-20
Sinsu-Dong, Mapo-Gu, Seoul, 121-110, Korea
PHONE +82-(0)2-783-5201~5203 FAX +82-(0)2-783-5204

The goods and their replicas, or the technology and software in this catalog are subject to complementary export regulations by Foreign Exchange and Foreign Trade Law of Japan.

If the goods and their replicas, or the technology and software in this catalog are to be exported, laws require the exporter to make sure they will never be used for the development or the manufacture of weapons for mass destruction.