



Series variation

Medium bore size cylinder CMA2 Series

● : Standard ◎ : Option ○ : Custom order ■ : Not available

Variation	Model no. JIS symbol	Bore size (mm)	Standard stroke length (mm)								Min. stroke length (mm)	Max. stroke length (mm)	Available stroke length (mm)	Custom stroke length (Per mm)	Mounting style								Option					Accessory			Switch	Page					
			25	50	75	100	150	200	250	300					Basic type	Axial foot type both sides	Axial foot type single	Rod side flange type	Head side flange type	Eye bracket type	Clevis bracket type	Rod side trunnion type	Head side trunnion type	Bellows (100 °C)	Bellows (250 °C)	Piston rod material change	Same port position	Copper and PTFE free	Rod eye	Rod clevis			Clevis bracket				
			00	LB	LS	FA	FB	CA	CB	TA					TB	J	L	M	P	P6	I	Y	B2														
Double acting	CMA2 	ϕ20 ϕ30 ϕ40	●	●	●	●	●	●	●	●	1	700	1000 1200 1500	1	●	●	●	●	●	●	●	●	◎	◎	◎	◎	◎	◎	◎	◎	◎	◎	◎	◎	◎	◎	194
Double acting direct mounting	CMA2-E 	ϕ20, ϕ30, ϕ40	●	●	●	●	●	●	●	●	1	700	700	1	■	■	●	●	■	■	■	■	■	■	◎	■	■	■	■	◎	◎	◎	◎	◎	206		

- SCP*2
- CMK2
- CMA2**
- SCM
- SCG
- SCA2
- SCS
- CKV2
- CA/OV2
- SSD
- CAT
- MDC2
- MVC
- SMD2
- MSD*
- FC*
- STK
- ULK*
- JSK/M2
- JSG
- JSC3
- USSD
- USC
- JSB3
- LMB
- STG
- STS/L
- LCS
- LCG
- LCM
- LCT
- LCY
- STR2
- UCA2
- HCM
- HCA
- SRL2
- SRG
- SRM
- SRT
- MRL2
- MRG2
- SM-25
- CAC3
- UCAC
- RCC2
- MFC
- SHC
- GLC
- Ending

- SCP*2
- CMK2
- CMA2**
- SCM
- SCG
- SCA2
- SCS
- CKV2
- CA/OV2
- SSD
- CAT
- MDC2
- MVC
- SMD2
- MSD*
- FC*
- STK
- ULK*
- JSK/M2
- JSG
- JSC3
- USSD
- USC
- JSB3
- LMB
- STG
- STS/L
- LCS
- LCG
- LCM
- LCT
- LCY
- STR2
- UCA2
- HCM
- HCA
- SRL2
- SRG
- SRM
- SRT
- MRL2
- MRG2
- SM-25
- CAC3
- UCAC
- RCC2
- MFC
- SHC
- GLC
- Ending

Medium bore size cylinder
Standard type

SCP*2
 CMK2
CMA2
 SCM
 SCG
 SCA2
 SCS
 CKV2
 CA/OV2
 SSD
 CAT
 MDC2
 MVC
 SMD2
 MSD*
 FC*
 STK
 ULK*
 JSK/M2
 JSG
 JSC3
 USSD
 USC
 JSB3
 LMB
 STG
 STS/L
 LCS
 LCG
 LCM
 LCT
 LCY
 STR2
 UCA2
 HCM
 HCA
 SRL2
 SRG
 SRM
 SRT
 MRL2
 MRG2
 SM-25
 CAC3
 UCAC
 RCC2
 MFC
 SHC
 GLC
 Ending

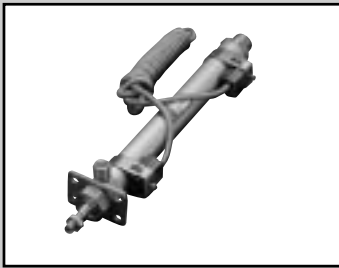

Medium bore size cylinder
 Standard type with switch

CMA2 Series

● Bore size: ϕ 20, ϕ 30, ϕ 40

JIS symbol ● Double acting cylinder single rod type

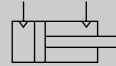

Specifications

Descriptions	CMA2		
Bore size mm	ϕ 20	ϕ 30	ϕ 40
Actuation	Double acting		
Working fluid	Compressed air		
Max. working pressure MPa	0.7		
Min. working pressure MPa	0.1		
Withstanding pressure MPa	1.05		
Ambient temperature °C	-10 to 60 (no freezing)		
Port size	Rc1/8		
Stroke tolerance mm	$^{+1.0}_0$ (up to 200), $^{+1.2}_0$ (up to 1000)		
Working piston speed mm/s	50 to 500		
Cushion	No		
Lubrication	Not required (when lubricating, use turbine oil Class 1 ISO VG32.)		
Allowable energy absorption J	0.024	0.05	0.093

Note: This product cannot absorb large energy generated by external load.
 We recommend to install an external buffer device additionally.

Stroke length

Bore size (mm)	Standard stroke length (mm)	Max. stroke length (mm)	Available stroke length (mm)	Min. stroke length (mm)
ϕ 20	25, 50, 75, 100	700	1000	1
ϕ 30	150, 200, 250		1200	
ϕ 40	300		1500	



Note 1: Custom stroke length is available per 1 mm increment.

Note 2: For single foot type (LS type), maximum stroke length is 50 mm.

Note 3: For bellows "J" type, stroke length should be longer than 25 mm. Consult with CKD when stroke length is shorter than 25 mm.

Note 4: If the maximum stroke is exceeded, product specifications may not be satisfied depending on conditions. Refer to page 74 at the end of this manual.

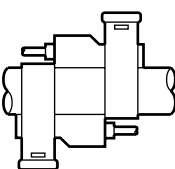
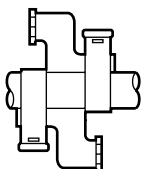
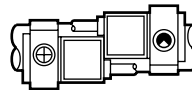
Min. stroke length of type with switch

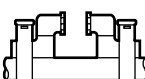
Rough sketch	Different surface installation		Same surface installation	
				
				(B)
Descriptions	Grommet	Terminal box	Grommet	Terminal box
ϕ 20	15 (10) mm	15 (10) mm	30 mm	32 mm (installation A) 80 mm (installation B)
ϕ 30				
ϕ 40				

● Note 1: When one switch is installed, refer to the value in ().

SCP*2
CMK2
CMA2
SCM
SCG
SCA2
SCS
CKV2
CA/OV2
SSD
CAT
MDC2
MVC
SMD2
MSD*
FC*
STK
ULK*
JSK/M2
JSG
JSC3
USSD
USC
JSB3
LMB
STG
STS/L
LCS
LCG
LCM
LCT
LCY
STR2
UCA2
HCM
HCA
SRL2
SRG
SRM
SRT
MRL2
MRG2
SM-25
CAC3
UCAC
RCC2
MFC
SHC
GLC
Ending

Switch specifications

Descriptions	Proximity 2-wire			Proximity 3-wire	
	R1	R2	R2Y (2-color indicator type)	R3	R3Y (2-color indicator type)
Applications	Programmable controller, Relay, small solenoid valve		Programmable controller dedicated	Programmable controller, relay, IC circuit, solenoid valve	
Output method	—————			NPN output	
Power voltage	—————			4.5 V to 28 VDC	
Load voltage and current	85 V to 265 VAC 5 to 100 mA	10 to 30 VDC 5 to 30 mA		30 VDC or less 200 mA or less 150 mA or less	
Light	LED (ON lighting)		Red/green LED (ON lighting)	LED (ON lighting)	Red/green LED (ON lighting)
Leakage current	1 mA or less with 100 VAC 2 mA or less with 200 VAC	1 mA or less	1.2 mA or less	10 μA or less	

Descriptions	Reed 2-wire			
	R0	R4	R5	R6
Applications	Relay, programmable controller	High capacity relay, solenoid valve	Programmable controller, relay, IC circuit (w/o light), serial connection	Programmable controller dedicated (with DC self hold)
Load voltage and current	12/24 VDC, 5 to 50 mA 110 VAC, 7 to 20 mA 220 VAC, 7 to 10 mA	110 VAC, 20 to 200 mA 220 VAC, 10 to 200 mA	5/12/24 VDC, 50 mA or less 110 VAC, 20 mA or less 220 VAC, 10 mA or less	24 VDC, 5 to 50 mA
Light	LED ON lighting	Neon light OFF lighting	None	LED ON lighting
Leakage current	0 mA	1 mA or less	0 mA	0.1 mA or less

Note 1: Refer to an Ending 1 page for other switch specifications.

Cylinder weight

(Unit: kg)

Descriptions/mounting style	Product weight when stroke length (S) = 0 mm					Switch weight		per S = 10 mm
	Basic type (00)	Axial foot type (LB)	Flange type (FA)	Clevis type (CA)	Trunnion type (TA/TB)	Grommet	Terminal box	
φ20	0.24	0.39	0.3	0.37	0.29	0.04	0.03	0.01
φ30	0.49	0.75	0.64	0.7	0.59	0.04	0.03	0.014
φ40	0.81	1.07	0.96	1.03	0.97	0.04	0.03	0.02

(E.g.) Product weight of CMA2-FA-30-50-RO-D ——— { When S = 0 mm, product weight is 0.64 kg
 Additional weight at S = 50 mm is additional weight at S = 10 mm 0.014 × $\frac{\text{Product stroke length (50)}}{10}$ = 0.07 kg
 Weight of two switches is 0.08 kg
 Product weight is 0.64 kg + 0.07 kg + 0.08 kg = 0.79 kg

Medium bore size cylinder
Standard type

How to order

Without switch

CMA2 - **FA** - **20** - **50** - _____ - **P** **I**

With switch

CMA2 - **FA** - **20** - **50** - **R0** - **R** - **P** **I**

A Mounting style
Note 1

B Bore size

C Stroke length

D Switch model no.

E Switch quantity

F Option
Note 3, Note 4, Note 5, Note 6

G Accessory
Note 7

⚠ Note on model no. selection

Note 1: The maximum stroke of the single-end foot type (LS type) is 50 mm.

Note 2: Refer to page 194 for min. stroke length with switch.

Note 3: For bellows "J" type, stroke length should be longer than 25 mm. Consult with CKD when stroke length is shorter than 25 mm.

Note 4: With the P type, the port alignment is adjusted with spacers so stroke direction dimensions (X, LL, XE dimensions) have a tolerance of 0 to 1.5 mm.

Note 5: Instantaneous maximum temperature is the temperature when spark and spatter etc. instantaneously contacts to bellows.

Note 6: When using the same port position type (P), the port alignment is adjusted with spacers, so X, LL, and XE dimensions have a tolerance of 0 to 1.5 mm.

Note 7: "I" "Y" can not be selected at the same time.

<Example of model number>

CMA2-FA-20-50-R0-R-PI

Model: Medium bore size cylinder, double acting, standard type

A Mounting style : Rod side flange type

B Bore size : ϕ 20 mm

C Stroke length : 50 mm

D Switch model no. : Reed R0 switch, lead wire 1 m

E Switch quantity : One on rod end

F Option : Same port position

G Accessory : Rod eye

Symbol	Descriptions
A Mounting style	
00	Basic type
LB	Axial foot type (both sides)
LS	Axial foot type (single)
FA	Rod side flange type
FB	Head side flange type
CA	Eye bracket type
CB	Clevis bracket type (pin and washer attached)
TA	Rod side trunnion type
TB	Head side trunnion type

B Bore size (mm)	
20	ϕ 20
30	ϕ 30
40	ϕ 40

C Stroke length (mm)			
Tube Inner diameter	Stroke length Note 2	Available Stroke length	Custom Stroke length
ϕ 20	1 to 700	1000	By 1 mm increment
ϕ 30	1 to 700	1200	
ϕ 40	1 to 700	1500	

D Switch model no.					
Grommet Type	Terminal box type		Contact	Indicator	Lead wire
	Standard type	Splash-proof			
R1*	R1B	R1A	Proximity	1 color indicator type	2-wire
R2*	R2B	R2A		2 color indicator type	
R2Y*	R2YB	R2YA		1 color indicator type	3-wire
R3*	R3B	R3A	2 color indicator type		
R3Y*	R3YB	R3YA	Reed	1 color indicator type	2-wire
R0*	R0B	R0A		Without indicator light	
R4*	R4B	R4A		1 color indicator type	
R5*	R5B	R5A		Without indicator light	
R6*	R6B	R6A		1 color indicator type	

* Lead wire length	
Blank	1 m (standard)
3	3 m (option)
5	5 m (option)

E Switch quantity	
R	One on rod end
H	One on head end
D	Two
T	Three

F Option			
		Max. ambient	Max. instantaneous
J	Bellows	100 °C	200 °C
L	Bellows	250 °C	400 °C
M	Piston rod material (stainless steel)		
P	Same port position		
P6	Copper and PTFE free		

G Accessory	
I	Rod eye
Y	Rod clevis (pin and washer attached)
B2	Clevis bracket (pin and snap ring attached)

How to order switch

● Switch body + mounting bracket

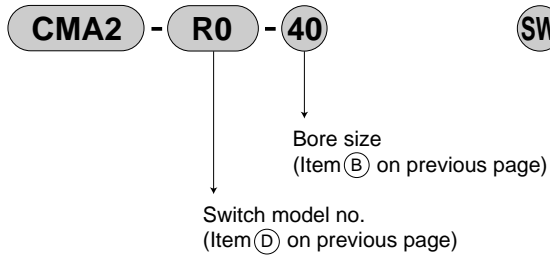

● Only switch body

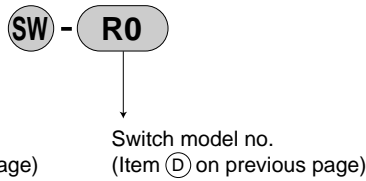

● Mounting bracket

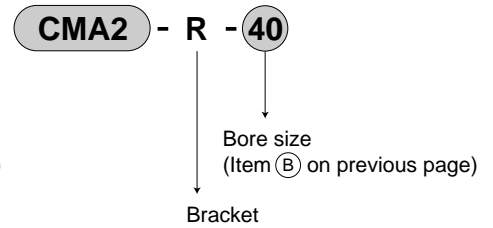

● Only terminal box

· For R* B

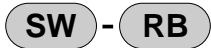

· For R* A

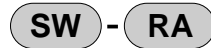

How to order mounting bracket

Bore size (mm)	φ 20	φ 30	φ 40
Axial foot type (LB/LS)	M1-LB-20	M1-LB-30	M1-LB-30
Flange type (FA/FB)	M1-FA-20	M1-FA-30	M1-FA-30
Eye bracket type (CA)	M1-CA-20	M1-CA-30	M1-CA-30
Clevis bracket type (CB)	M1-CB-20	M1-CB-30	M1-CB-30
Trunnion type (TA/TB)	M1-TA-20	M1-TA-30	M1-TA-40

Note 1: The above mounting bracket model no. includes nut, toothed washer and parallel pin etc.

Note 2: Two sets of "M1-LB-*" in the above table are required for the axial direction foot (double-sided).

- SCP*2
- CMK2
- CMA2**
- SCM
- SCG
- SCA2
- SCS
- CKV2
- CA/OV2
- SSD
- CAT
- MDC2
- MVC
- SMD2
- MSD*
- FC*
- STK
- ULK*
- JSK/M2
- JSG
- JSC3
- USSD
- USC
- JSB3
- LMB
- STG
- STS/L
- LCS
- LCG
- LCM
- LCT
- LCY
- STR2
- UCA2
- HCM
- HCA
- SRL2
- SRG
- SRM
- SRT
- MRL2
- MRG2
- SM-25
- CAC3
- UCAC
- RCC2
- MFC
- SHC
- GLC
- Ending

Medium bore size cylinder
Standard type

Internal structure and parts list

● CMA2

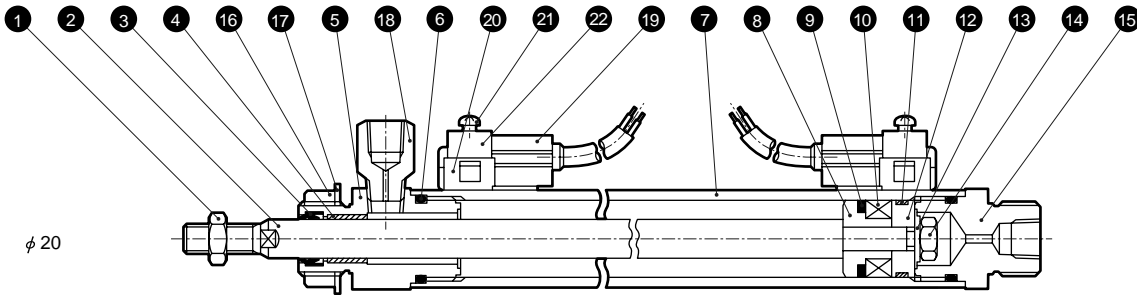

φ 20

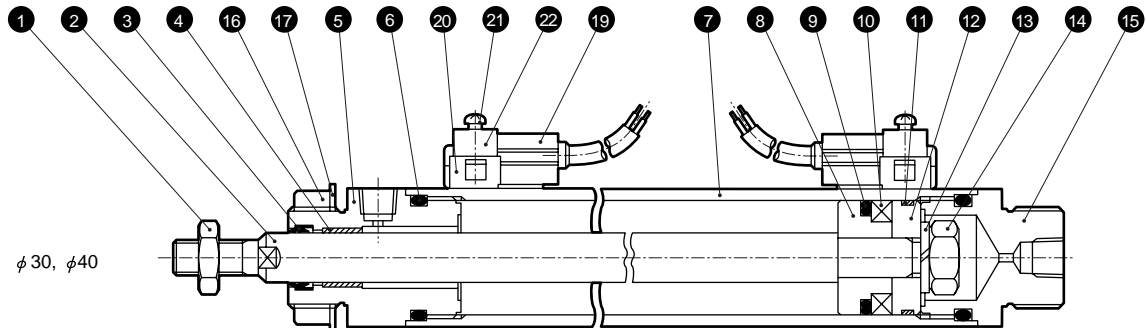

φ 30, φ 40

No.	Parts name	Material	Remarks	No.	Parts name	Material	Remarks
1	Rod nut	Steel	Zinc chromate	12	Piston B	Aluminum alloy	
2	Piston rod	φ20, φ30 stainless steel φ 40 carbon steel	Industrial-use chrome plating	13	Spring washer	Steel	Zinc chromate
3	Rod packing seal	Nitrile rubber		14	Hexagon nut	Steel	Zinc chromate
4	Bush	Dry bearing	Note 1	15	Head cover	Steel	Zinc chromate
5	Rod cover	Steel	Zinc chromate	16	Nut	Steel	Zinc chromate
6	Cylinder gasket	Nitrile rubber		17	The toothed washer	Steel	Zinc chromate
7	Cylinder tube	Aluminum alloy	Hard alumite	18	Port nipple	Brass	Note 2
8	Piston A	Aluminum alloy		With switch			
9	Piston packing seal	Nitrile rubber		19	Switch body		
10	Magnet	Plastic		20	Band	Stainless steel	
11	Wear ring	Polyacetal resin		21	Pan head machine screw	Steel	Zinc chromate
				22	Bracket	Stainless steel	

Note 1: Oil impregnated resin bearing is used for copper and PTFE free specifications.

Note 2: For copper and PTFE free specifications, port nipple material of brass is nickel plated.

Repair parts list

Bore size (mm)	Kit No.	Repair parts number
φ 20	CMA2-20K	
φ 30	CMA2-30K	● 3 ● 6 ● 9 ● 11
φ 40	CMA2-40K	

Mounting bracket material

Mounting style	Material
LB/LS	SPCC
FA/FB	SPCC
TA/TB	S50C
CA/CB	SS400

● Note: Mounting bracket is attached to the product when shipped.

Dimensions



● R type basic type with switch (00)

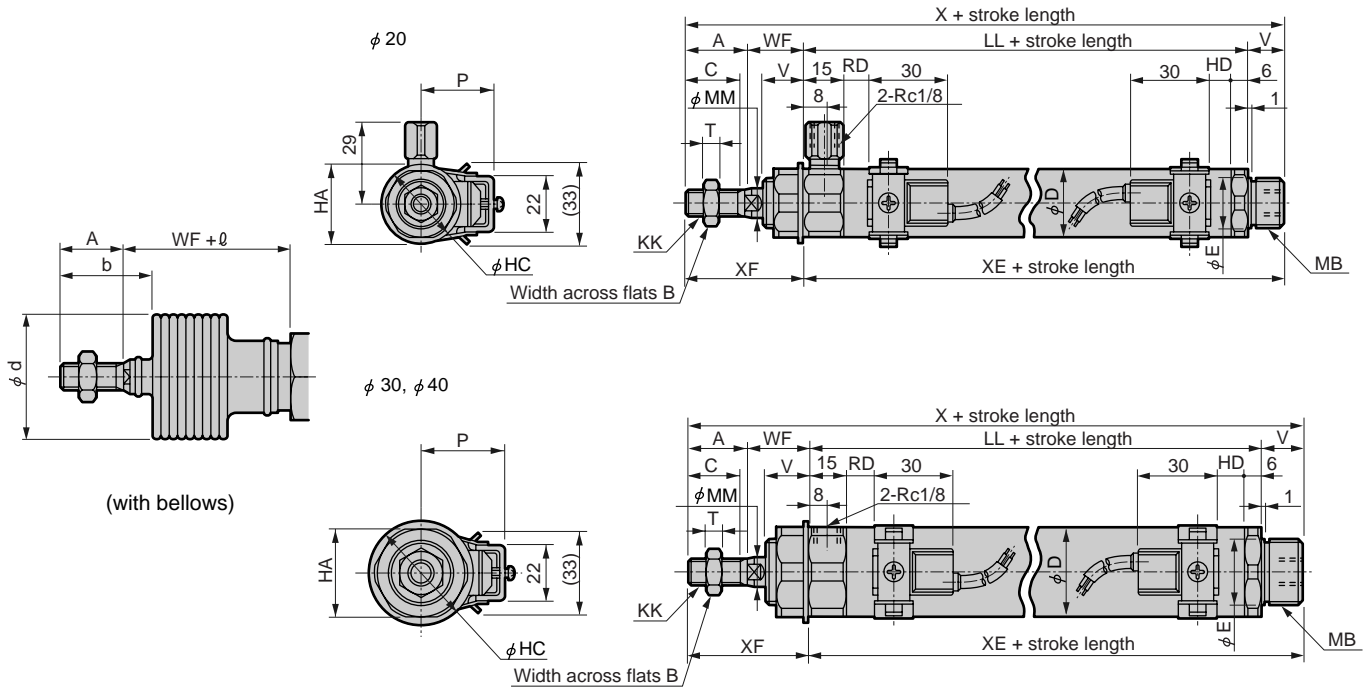

● R type switch terminal box basic type (00)

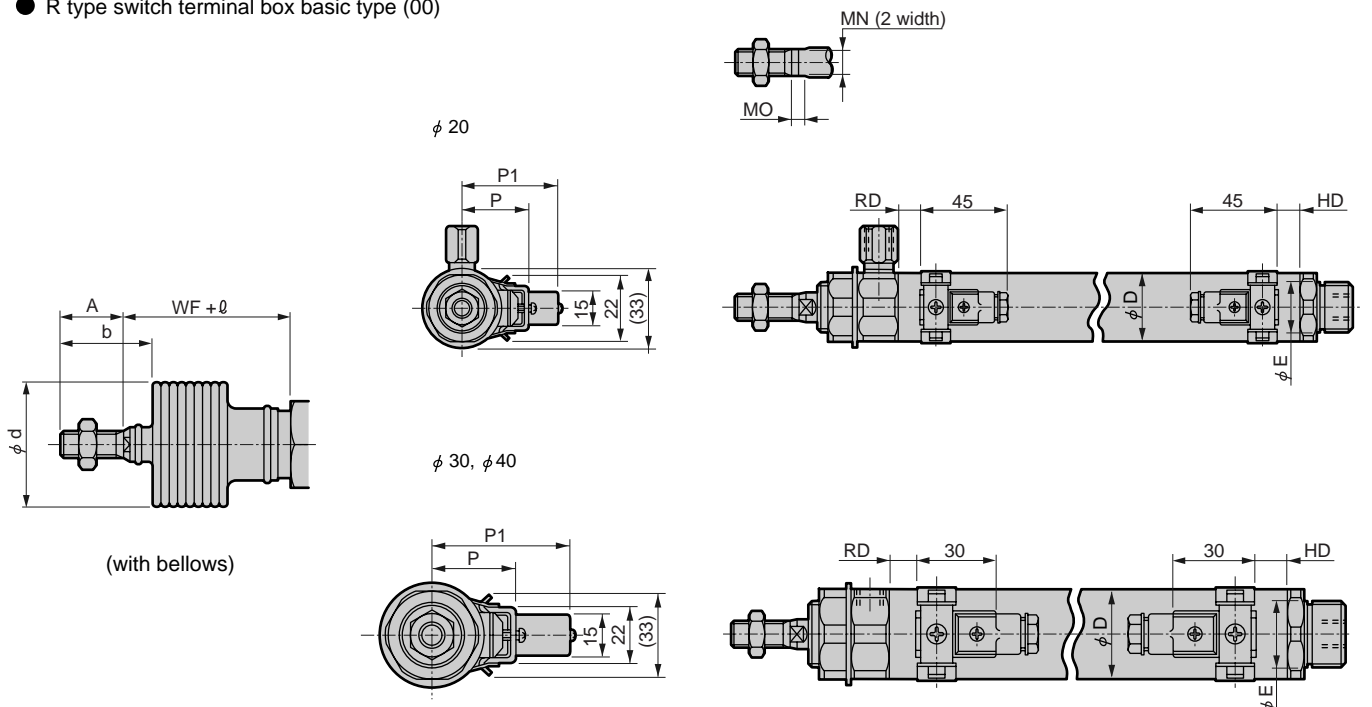

Note 1: Port nipple is attached to rod cover for φ 20 .

Note 2: For l dimensions, round up decimal point or less.

Note 3: Refer to page 212 for dimensions of accessories.

RD: Rod side max. sensitive position

HD: Head side max. sensitive position

Symbol	Basic type (00) basic dimensions																		
Bore size (mm)	A	B	C	D	E	HA	HC	KK	LL	MB	MN	MO	MM	T	V	WF	X	XE	XF
φ20	20	13	18	25	18	26	29	M8 x 1	66	M18 x 1.5	8	5	10	5	14	24	124	80	44
φ30	23	17	20	35	26	35	41	M10 x 1.25	72	M26 x 1.5	10	5	12	6	16	23	134	88	46
φ40	25	19	22	45	26	35	41	M12 x 1.5	74	M26 x 1.5	12	6	14	7	16	23	138	90	48

Symbol	With switch				With bellows					
Bore size (mm)	HD	P	PI	RD	A	WF	b	d	l	
φ20	7.5	28	48	7.5	20	24	30	30	(stroke length/3) + 6	
φ30	10.5	34	54	10.5	23	23	32	46	(stroke length/3.25) + 7	
φ40	11.5	39	59	11.5	25	23	34	46	(stroke length/3.25) + 7	

- SCP*2
- CMK2
- CMA2**
- SCM
- SCG
- SCA2
- SCS
- CKV2
- CA/OV2
- SSD
- CAT
- MDC2
- MVC
- SMD2
- MSD*
- FC*
- STK
- ULK*
- JSK/M2
- JSG
- JSC3
- USSD
- USC
- JSB3
- LMB
- STG
- STS/L
- LCS
- LCG
- LCM
- LCT
- LCY
- STR2
- UCA2
- HCM
- HCA
- SRL2
- SRG
- SRM
- SRT
- MRL2
- MRG2
- SM-25
- CAC3
- UCAC
- RCC2
- MFC
- SHC
- GLC
- Ending

Medium bore size cylinder
Standard type

Dimensions



● Axial foot type (LB)

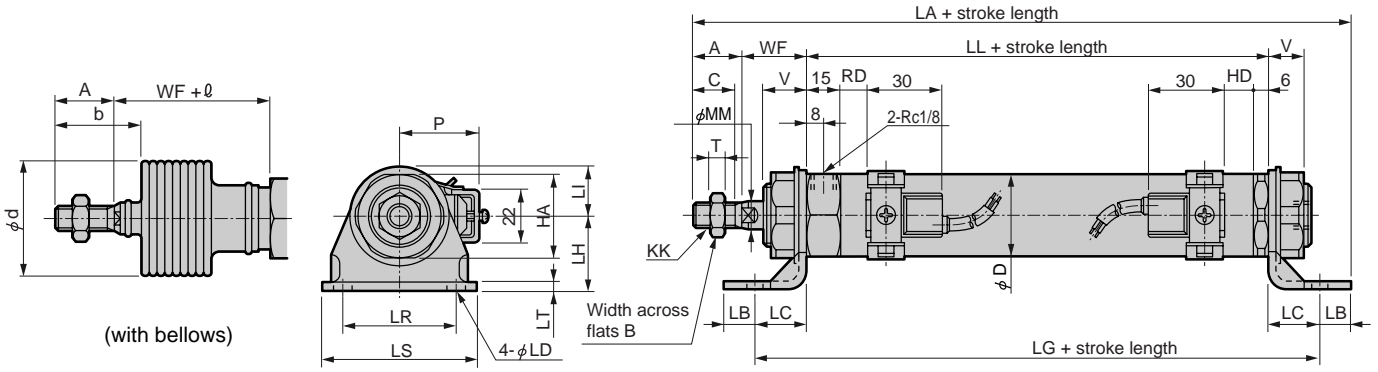

Note 1: Refer to basic type (00) about dimensions of rod width across flat.

Note 2: Port nipple is attached to rod cover for φ 20 .

Note 3: For l dimensions, round up decimal point or less.

Note 4: Refer to page 212 for dimensions of accessories.

Symbol	Axial foot type LB basic dimensions											Installation dimensions									
	A	B	C	D	HA	KK	LL	MM	T	V	WF	LA	LB	LC	LD	LG	LH	LI	LR	LS	LT
φ20	20	13	18	25	26	M8 x 1	66	10	5	14	24	138	10	18	6	102	25	15	30	44	3.2
φ30	23	17	20	35	35	M10 x 1.25	72	12	6	16	23	153	12	23	7	118	30	20	46	62	3.2
φ40	25	19	22	45	35	M12 x 1.5	74	14	7	16	23	157	12	23	7	120	30	20	46	62	3.2

Symbol	With switch			With bellows						
	HD	P	RD	A	WF	b	d	l		
φ20	7.5	28	7.5	20	24	30	30	(stroke length/3) + 6		
φ30	10.5	34	10.5	23	23	32	46	(stroke length/3.25) + 7		
φ40	11.5	39	11.5	25	23	34	46	(stroke length/3.25) + 7		

● Single axial foot type (LS)

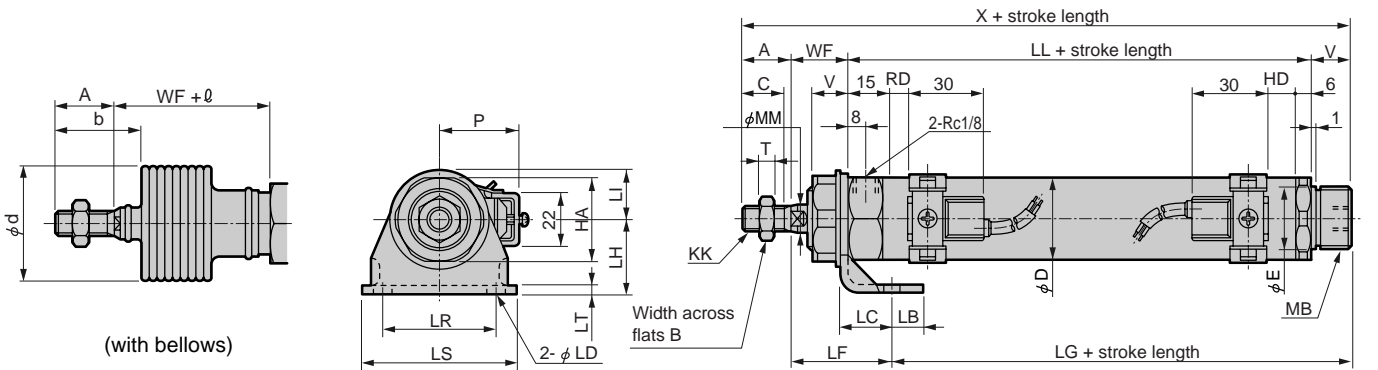

Note 1: Up to 50 mm stroke.

Note 2: Refer to basic type (00) about dimensions of rod width across flat.

Note 3: Port nipple is attached to rod cover for φ 20 .

Note 4: For l dimensions, round up decimal point or less.

Note 5: Refer to page 212 for dimensions of accessories.

Symbol	Single axial foot type (LS) basic dimensions													Installation dimensions					
	A	B	C	D	E	HA	KK	LL	MB	MM	T	V	WF	X	LB	LC	LD	LF	LG
φ20	20	13	18	25	18	26	M8 x 1	66	M18 x 1.5	10	5	14	24	124	10	18	6	38.8	65.2
φ30	23	17	20	35	26	35	M10 x 1.25	72	M26 x 1.5	12	6	16	23	134	12	23	7	42.8	68.2
φ40	25	19	22	45	26	35	M12 x 1.5	74	M26 x 1.5	14	7	16	23	138	12	23	7	42.8	70.2

Symbol	With switch			With bellows										
	LH	LI	LR	LS	LT	HD	P	RD	A	WF	b	d	l	
φ20	25	15	30	44	3.2	7.5	28	7.5	20	24	30	30	(stroke length/3) + 6	
φ30	30	20	46	62	3.2	10.5	34	10.5	23	23	32	46	(stroke length/3.25) + 7	
φ40	30	20	46	62	3.2	11.5	39	11.5	25	23	34	46	(stroke length/3.25) + 7	

Dimensions



● Rod side flange type (FA)

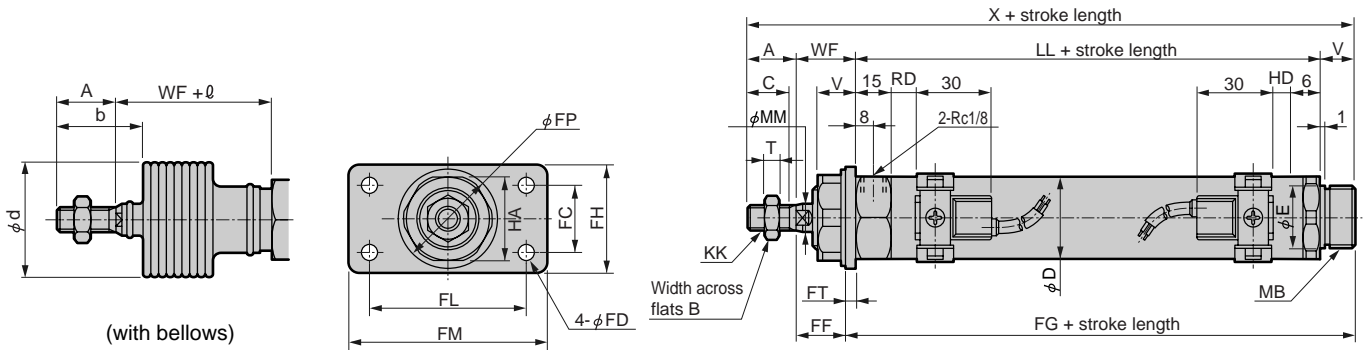

Note 1: Refer to basic type (00) about dimensions of rod width across flat.
 Note 2: Port nipple is attached to rod cover for φ 20 .
 Note 3: For ℓ dimensions, round up decimal point or less.
 Note 4: Refer to page 212 for dimensions of accessories.

Symbol	Rod side flange type (FA) basic dimensions														Installation dimensions				
Bore size (mm)	A	B	C	D	E	HA	KK	LL	MB	MM	T	V	WF	X	FC	FD	FF	FG	FH
φ20	20	13	18	25	18	26	M8 x 1	66	M18 x 1.5	10	5	14	24	124	20	6	20.8	83.2	34
φ30	23	17	20	35	26	35	M10 x 1.25	72	M26 x 1.5	12	6	16	23	134	28	7	18.5	92.5	44
φ40	25	19	22	45	26	35	M12 x 1.5	74	M26 x 1.5	14	7	16	23	138	28	7	18.5	94.5	44

Symbol	With switch							With bellows				
Bore size (mm)	FL	FM	FP	FT	HD	P	RD	A	WF	b	d	ℓ
φ20	40	54	29	3.2	7.5	28	7.5	20	24	30	30	(stroke length/3) + 6
φ30	64	80	41	4.5	10.5	34	10.5	23	23	32	46	(stroke length/3.25) + 7
φ40	64	80	41	4.5	11.5	39	11.5	25	23	34	46	(stroke length/3.25) + 7

● Head side flange type (FB)

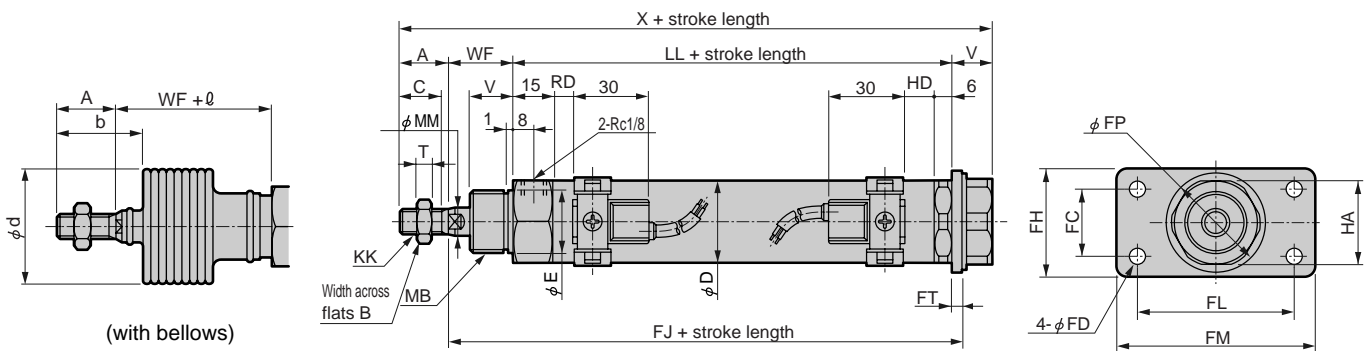

Note 1: Refer to basic type (00) about dimensions of rod width across flat.
 Note 2: Port nipple is attached to rod cover for φ 20 .
 Note 3: For ℓ dimensions, round up decimal point or less.
 Note 4: Refer to page 212 for dimensions of accessories.

Symbol	Head side flange type (FB) basic dimensions														Installation dimensions				
Bore size (mm)	A	B	C	D	E	HA	KK	LL	MB	MM	T	V	WF	X	FC	FD	FH	FJ	FL
φ20	20	13	18	25	18	26	M8 x 1	66	M18 x 1.5	10	5	14	24	124	20	6	34	93.2	40
φ30	23	17	20	35	26	35	M10 x 1.25	72	M26 x 1.5	12	6	16	23	134	28	7	44	99.5	64
φ40	25	19	22	45	26	35	M12 x 1.5	74	M26 x 1.5	14	7	16	23	138	28	7	44	101.5	64

Symbol	With switch							With bellows				
Bore size (mm)	FM	FP	FT	HD	P	RD	A	WF	b	d	ℓ	
φ20	54	29	3.2	7.5	28	7.5	20	24	30	30	(stroke length/3) + 6	
φ30	80	41	4.5	10.5	34	10.5	23	23	32	46	(stroke length/3.25) + 7	
φ40	80	41	4.5	11.5	39	11.5	25	23	34	46	(stroke length/3.25) + 7	

- SCP*2
- CMK2
- CMA2**
- SCM
- SCG
- SCA2
- SCS
- CKV2
- CA/OV2
- SSD
- CAT
- MDC2
- MVC
- SMD2
- MSD*
- FC*
- STK
- ULK*
- JSK/M2
- JSG
- JSC3
- USSD
- USC
- JSB3
- LMB
- STG
- STS/L
- LCS
- LCG
- LCM
- LCT
- LCY
- STR2
- UCA2
- HCM
- HCA
- SRL2
- SRG
- SRM
- SRT
- MRL2
- MRG2
- SM-25
- CAC3
- UCAC
- RCC2
- MFC
- SHC
- GLC
- Ending

Medium bore size cylinder
Standard type

Dimensions

● Rod side trunnion type (TA)

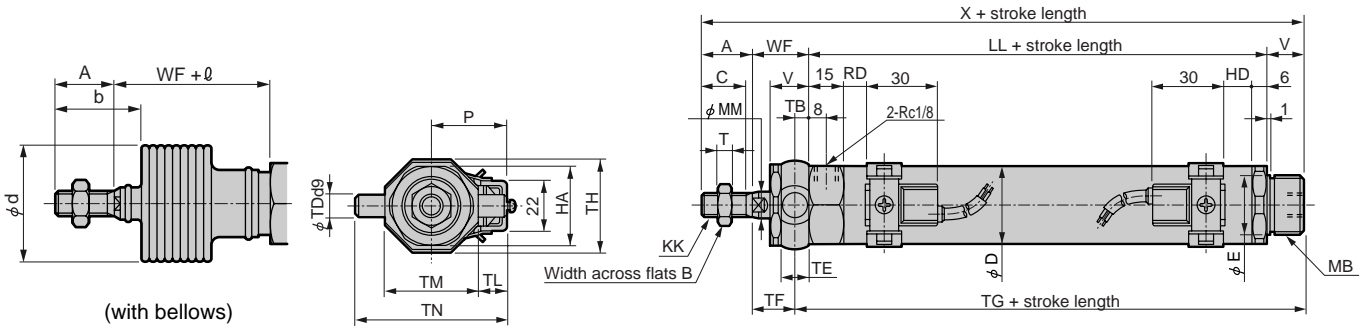

Note 1: Refer to basic type (00) about dimensions of rod width across flat.
 Note 2: Port nipple is attached to rod cover for φ 20 .
 Note 3: For ℓ dimensions, round up decimal point or less.
 Note 4: Refer to page 212 for dimensions of accessories.

Symbol	Rod side trunnion type (TA) basic dimensions														Installation dimensions				
	A	B	C	D	E	HA	KK	LL	MB	MM	T	V	WF	X	TB	TD	TE	TF	TG
φ20	20	13	18	25	18	26	M8 x 1.0	66	M18 x 1.5	10	5	14	24	124	4.5	8 ^{-0.040} _{-0.076}	9	19.5	84.5
φ30	23	17	20	35	26	35	M10 x 1.25	72	M26 x 1.5	12	6	16	23	134	5.5	10 ^{-0.040} _{-0.076}	11	17.5	93.5
φ40	25	19	22	45	26	35	M12 x 1.5	74	M26 x 1.5	14	7	16	23	138	5.5	10 ^{-0.040} _{-0.076}	11	17.5	95.5

Symbol	With switch				With bellows				ℓ			
	TH	TL	TM	TN	HD	P	RD	A		WF	b	d
φ20	29.5	8	30	46	7.5	28	7.5	20	24	30	30	(stroke length/3) + 6
φ30	39	12	40	64	10.5	34	10.5	23	23	32	46	(stroke length/3.25) + 7
φ40	44	9.5	53	72	11.5	39	11.5	25	23	34	46	(stroke length/3.25) + 7

● Rod side trunnion type (TA) with bracket (option symbol B2)

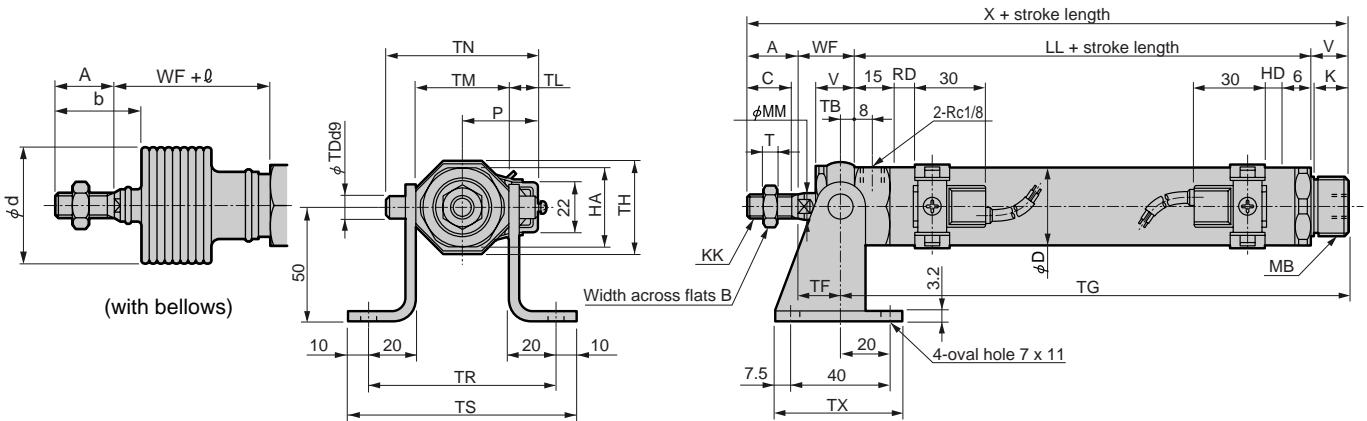

Note 1: Refer to basic type (00) about dimensions of rod width across flat.
 Note 2: Port nipple is attached to rod cover for φ 20 .
 Note 3: For ℓ dimensions, round up decimal point or less.
 Note 4: Refer to page 212 for dimensions of accessories.

Symbol	Rod side trunnion type (TA) with bracket (option symbol B2) basic dimensions														Installation dimensions				
	A	B	C	D	HA	K	KK	LL	MB	MM	T	V	WF	X	TB	TD	TF	TG	TH
φ20	20	13	18	25	26	12	M8 x 1.0	66	M18 x 1.5	10	5	14	24	124	4.5	8 ^{-0.040} _{-0.076}	19.5	84.5	29.5
φ30	23	17	20	35	35	14	M10 x 1.25	72	M26 x 1.5	12	6	16	23	134	5.5	10 ^{-0.040} _{-0.076}	17.5	93.5	39
φ40	25	19	22	45	35	14	M12 x 1.5	74	M26 x 1.5	14	7	16	23	138	5.5	10 ^{-0.040} _{-0.076}	17.5	95.5	44

Symbol	With switch				With bellows				ℓ					
	TL	TM	TN	TR	TS	TX	HD	P		RD	A	WF	b	d
φ20	8	30	46	70	90	55	7.5	28	7.5	20	24	30	30	(stroke length/3) + 6
φ30	12	40	64	80	100	55	10.5	34	10.5	23	23	32	46	(stroke length/3.25) + 7
φ40	9.5	53	72	93	113	55	11.5	39	11.5	25	23	34	46	(stroke length/3.25) + 7

Dimensions

● Head side trunnion type (TB)

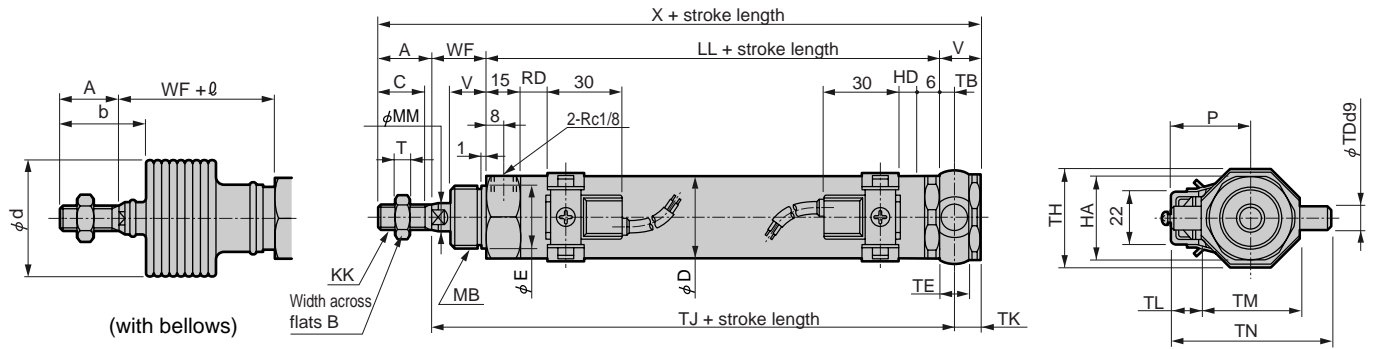

Note 1: Refer to basic type (00) about dimensions of rod width across flat.
 Note 2: Port nipple is attached to rod cover for $\phi 20$.
 Note 3: For ℓ dimensions, round up decimal point or less.
 Note 4: Refer to page 212 for dimensions of accessories.

Symbol	Head side trunnion type (TB) basic dimensions														Installation dimensions				
Bore size (mm)	A	B	C	D	E	HA	KK	LL	MB	MM	T	V	WF	X	TB	TD	TE	TH	TJ
$\phi 20$	20	13	18	25	18	26	M8 x 1.0	66	M18 x 1.5	10	5	14	24	124	4.5	8 ^{-0.040} _{-0.076}	9	29.5	94.5
$\phi 30$	23	17	20	35	26	35	M10 x 1.25	72	M26 x 1.5	12	6	16	23	134	5.5	10 ^{-0.040} _{-0.076}	11	39	100.5
$\phi 40$	25	19	22	45	26	35	M12 x 1.5	74	M26 x 1.5	14	7	16	23	138	5.5	10 ^{-0.040} _{-0.076}	11	44	102.5
Symbol	With switch				With bellows														
Bore size (mm)	TK	TL	TM	TN	HD	P	RD	A	WF	b	d	ℓ							
$\phi 20$	9.5	8	30	46	7.5	28	7.5	20	24	30	30	(stroke length/3) + 6							
$\phi 30$	10.5	12	40	64	10.5	34	10.5	23	23	32	46	(stroke length/3.25) + 7							
$\phi 40$	10.5	9.5	53	72	11.5	39	11.5	25	23	34	46	(stroke length/3.25) + 7							

● Head side trunnion type (TB) with bracket (option symbol B2)

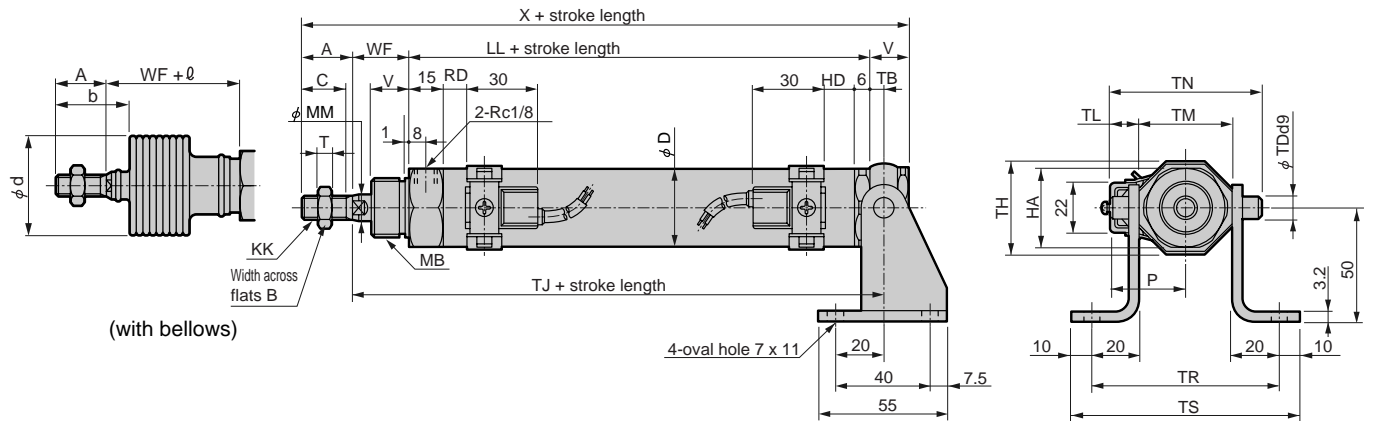

Note 1: Refer to basic type (00) about dimensions of rod width across flat.
 Note 2: Port nipple is attached to rod cover for $\phi 20$.
 Note 3: For ℓ dimensions, round up decimal point or less.
 Note 4: Refer to page 212 for dimensions of accessories.

Symbol	Head side trunnion type (TB) with bracket (option symbol B2) basic dimensions														Installation dimensions				
Bore size (mm)	A	B	C	D	HA	KK	LL	MB	MM	T	V	WF	X	TB	TD	TH	TJ	TL	TM
$\phi 20$	20	13	18	25	26	M8 x 1.0	66	M18 x 1.5	10	5	14	24	124	4.5	8 ^{-0.040} _{-0.076}	29.5	94.5	8	30
$\phi 30$	23	17	20	35	35	M10 x 1.25	72	M26 x 1.5	12	6	16	23	134	5.5	10 ^{-0.040} _{-0.076}	39	100.5	12	40
$\phi 40$	25	19	22	45	35	M12 x 1.5	74	M26 x 1.5	14	7	16	23	138	5.5	10 ^{-0.040} _{-0.076}	44	102.5	9.5	53
Symbol	With switch				With bellows														
Bore size (mm)	TN	TR	TS	HD	P	RD	A	WF	b	d	ℓ								
$\phi 20$	46	70	90	7.5	28	7.5	20	24	30	30	(stroke length/3) + 6								
$\phi 30$	64	80	100	10.5	34	10.5	23	23	32	46	(stroke length/3.25) + 7								
$\phi 40$	72	93	113	11.5	39	11.5	25	23	34	46	(stroke length/3.25) + 7								

- SCP*2
- CMK2
- CMA2**
- SCM
- SCG
- SCA2
- SCS
- CKV2
- CA/OV2
- SSD
- CAT
- MDC2
- MVC
- SMD2
- MSD*
- FC*
- STK
- ULK*
- JSK/M2
- JSG
- JSC3
- USSD
- USC
- JSB3
- LMB
- STG
- STS/L
- LCS
- LCG
- LCM
- LCT
- LCY
- STR2
- UCA2
- HCM
- HCA
- SRL2
- SRG
- SRM
- SRT
- MRL2
- MRG2
- SM-25
- CAC3
- UCAC
- RCC2
- MFC
- SHC
- GLC
- Ending

Medium bore size cylinder
Standard type

Dimensions

● Eye bracket type (CA)

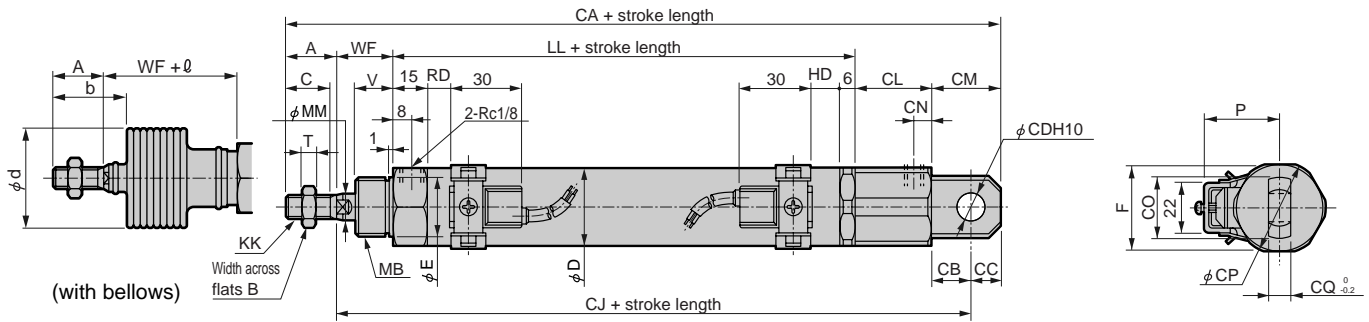

Note 1: Refer to basic type (00) about dimensions of rod width across flat.
 Note 2: Port nipple is attached to rod cover for φ 20 .
 Note 3: For ℓ dimensions, round up decimal point or less.
 Note 4: Refer to page 212 for dimensions of accessories.

Symbol	Eye bracket type (CA) basic dimensions													Installation dimensions					
Bore size (mm)	A	B	C	D	E	F	KK	LL	MB	MM	T	V	WF	CA	CB	CC	CD	CJ	CL
φ20	20	13	18	25	18	26	M8 x 1.0	66	M18 x 1.5	10	5	14	24	165	14	10	10 ^{+0.068} ₀	135	31
φ30	23	17	20	35	26	35	M10 x 1.25	72	M26 x 1.5	12	6	16	23	180	18	12	12 ^{+0.070} ₀	145	32
φ40	25	19	22	45	26	35	M12 x 1.5	74	M26 x 1.5	14	7	16	23	184	18	12	12 ^{+0.070} ₀	147	32

Symbol	With switch					With bellows							
Bore size (mm)	CM	CN	CO	CP	CQ	HD	P	RD	A	WF	b	d	ℓ
φ20	24	8	22	28	8	7.5	28	7.5	20	24	30	30	(stroke length/3) + 6
φ30	30	7	26	37	10	10.5	34	10.5	23	23	32	46	(stroke length/3.25) + 7
φ40	30	7	26	37	10	11.5	39	11.5	25	23	34	46	(stroke length/3.25) + 7

● Eye bracket type (CA) with bracket (option symbol B2)

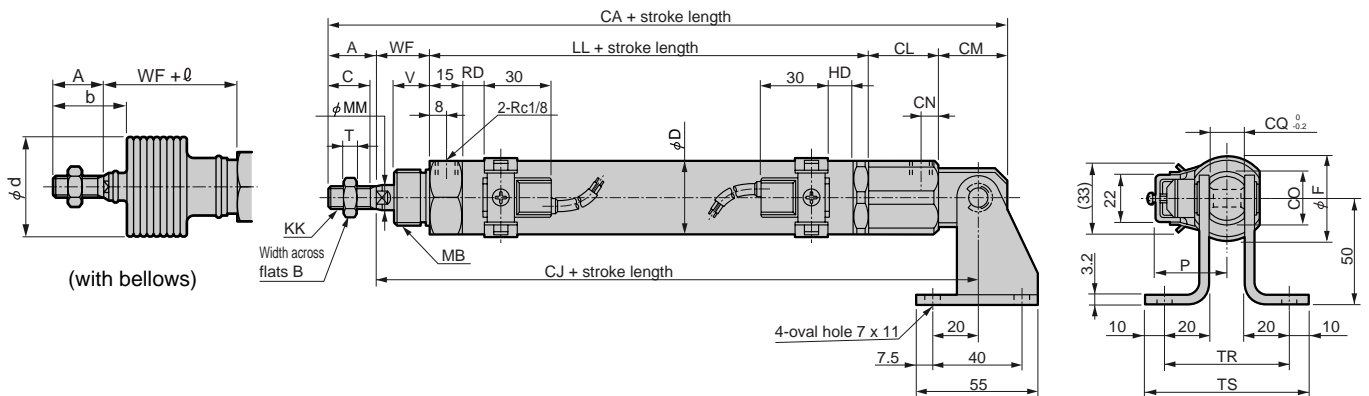

Note 1: Refer to basic type (00) about dimensions of rod width across flat.
 Note 2: Port nipple is attached to rod cover for φ 20 .
 Note 3: For ℓ dimensions, round up decimal point or less.
 Note 4: Refer to page 212 for dimensions of accessories.

Symbol	Eye bracket type (CA) with bracket (option symbol B2) basic dimensions													Installation dimensions					
Bore size (mm)	A	B	C	D	F	KK	LL	MB	MM	T	V	WF	CA	CJ	CL	CM	CN	CO	CQ
φ20	20	13	18	25	26	M8 x 1.0	66	M18 x 1.5	10	5	14	24	165	135	31	24	8	22	8
φ30	23	17	20	35	35	M10 x 1.25	72	M26 x 1.5	12	6	16	23	180	145	32	30	7	26	10
φ40	25	19	22	45	35	M12 x 1.5	74	M26 x 1.5	14	7	16	23	184	147	32	30	7	26	10

Symbol	With switch					With bellows				
Bore size (mm)	TR	TS	HD	P	RD	A	WF	b	d	ℓ
φ20	48	68	7.5	28	7.5	20	24	30	30	(stroke length/3) + 6
φ30	50	70	10.5	34	10.5	23	23	32	46	(stroke length/3.25) + 7
φ40	50	70	11.5	39	11.5	25	23	34	46	(stroke length/3.25) + 7

Dimensions

● Clevis bracket type (CB)

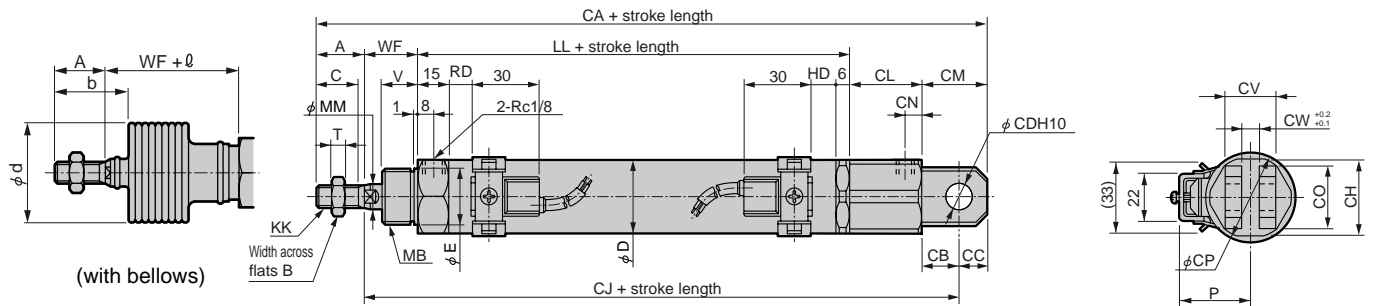

Note 1: Refer to basic type (00) about dimensions of rod width across flat.
 Note 2: Port nipple is attached to rod cover for φ 20.
 Note 3: For l dimensions, round up decimal point or less.
 Note 4: Refer to page 212 for dimensions of accessories.

Symbol	Clevis bracket type (CB) basic dimensions.											Installation dimensions							
Bore size (mm)	A	B	C	D	E	KK	LL	MB	MM	T	V	WF	CA	CB	CC	CD	CH	CJ	CL
φ20	20	13	18	25	18	M8 x 1.0	66	M18 x 1.5	10	5	14	24	165	14	10	10 ^{+0.058} ₀	26	135	31
φ30	23	17	20	35	26	M10 x 1.25	72	M26 x 1.5	12	6	16	23	180	18	12	12 ^{+0.070} ₀	35	145	32
φ40	25	19	22	45	26	M12 x 1.5	74	M26 x 1.5	14	7	16	23	184	18	12	12 ^{+0.070} ₀	35	147	32

Symbol	With switch						With bellows							
Bore size (mm)	CM	CN	CO	CP	CV	CW	HD	P	RD	A	WF	b	d	l
φ20	24	8	22	28	19	8	7.5	28	7.5	20	24	30	30	(stroke length/3) + 6
φ30	30	7	26	37	25	10	10.5	34	10.5	23	23	32	46	(stroke length/3.25) + 7
φ40	30	7	26	37	25	10	11.5	39	11.5	25	23	34	46	(stroke length/3.25) + 7

● Same port position type (P)

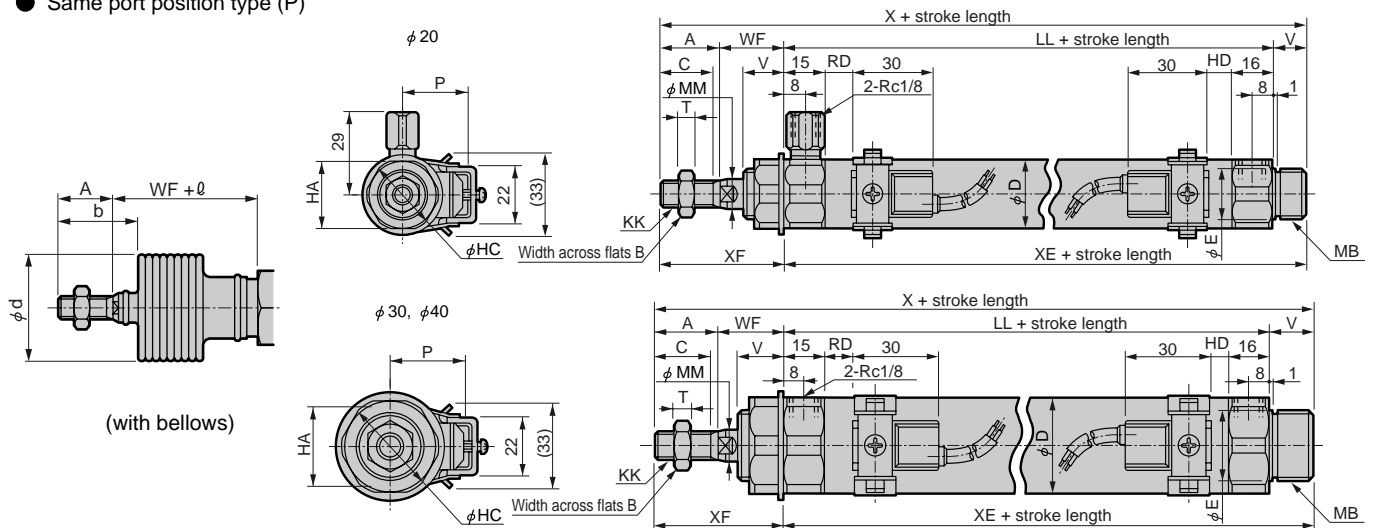

Note 1: Port nipple is attached to rod cover for φ 20.
 Note 2: Refer to basic type (00) about dimensions of rod width across flat.
 Note 3: For l dimensions, round up decimal point or less.
 Note 4: The port alignment is adjusted with spacers, so X, LL, and XE dimensions have a tolerance of 0 to 1.5 mm.
 Note 5: Refer to page 212 for dimensions of accessories.
 RD: Rod side max. sensitive position
 HD: Head side max. sensitive position

Symbol	Basic type (00) basic dimensions																
Bore size (mm)	A	B	C	D	E	HA	HC	KK	LL Note 4	MB	MM	T	V	WF	X Note 4	XE Note 4	XF
φ20	20	13	18	25	18	26	29	M8 x 1.0	76 to 77.5	M18 x 1.5	10	5	14	24	134 to 135.5	90 to 91.5	44
φ30	23	17	20	35	26	35	41	M10 x 1.25	82 to 83.5	M26 x 1.5	12	6	16	23	144 to 145.5	98 to 99.5	46
φ40	25	19	22	45	26	35	41	M12 x 1.5	84 to 85.5	M26 x 1.5	14	7	16	23	148 to 149.5	100 to 101.5	48

Symbol	With switch						With bellows					
Bore size (mm)	HD	P	RD	A	WF	b	d	l				
φ20	7.5	28	7.5	20	24	30	30	(stroke length/3) + 6				
φ30	10.5	34	10.5	23	23	32	46	(stroke length/3.25) + 7				
φ40	11.5	39	11.5	25	23	34	46	(stroke length/3.25) + 7				

SCP*2
 CMK2
CMA2
 SCM
 SCG
 SCA2
 SCS
 CKV2
 CA/OV2
 SSD
 CAT
 MDC2
 MVC
 SMD2
 MSD*
 FC*
 STK
 ULK*
 JSK/M2
 JSG
 JSC3
 USSD
 USC
 JSB3
 LMB
 STG
 STS/L
 LCS
 LCG
 LCM
 LCT
 LCY
 STR2
 UCA2
 HCM
 HCA
 SRL2
 SRG
 SRM
 SRT
 MRL2
 MRG2
 SM-25
 CAC3
 UCAC
 RCC2
 MFC
 SHC
 GLC
 Ending

Medium bore size cylinder
 Standard type

SCP*2
 CMK2
CMA2
 SCM
 SCG
 SCA2
 SCS
 CKV2
 CA/OV2
 SSD
 CAT
 MDC2
 MVC
 SMD2
 MSD*
 FC*
 STK
 ULK*
 JSK/M2
 JSG
 JSC3
 USSD
 USC
 JSB3
 LMB
 STG
 STS/L
 LCS
 LCG
 LCM
 LCT
 LCY
 STR2
 UCA2
 HCM
 HCA
 SRL2
 SRG
 SRM
 SRT
 MRL2
 MRG2
 SM-25
 CAC3
 UCAC
 RCC2
 MFC
 SHC
 GLC
 Ending

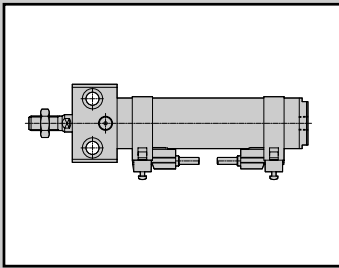

Medium bore size cylinder
 Double acting direct mounting type

CMA2-E Series

● Bore size: ϕ 20, ϕ 30, ϕ 40

JIS symbol ● Double acting cylinder single rod type

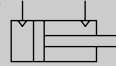

Specifications

Descriptions	CMA2-E		
Bore size mm	ϕ 20	ϕ 30	ϕ 40
Actuation	Double acting		
Working fluid	Compressed air		
Max. working pressure MPa	0.7		
Min. working pressure MPa	0.1		
Withstanding pressure MPa	1.0		
Ambient temperature °C	-10 to 60 (no freezing)		
Port size	Rc1/8		
Stroke tolerance mm	$^{+1.0}_0$ (up to 200), $^{+1.2}_0$ (up to 1000)		
Working piston speed mm/s	50 to 500		
Cushion	No		
Lubrication	Not required (when lubricating, use turbine oil Class 1 ISO VG32.)		
Allowable energy absorption J	0.024	0.05	0.093

Stroke length

Bore size (mm)	Standard stroke length (mm)	Max. stroke length (mm)	Min. stroke length (mm)
ϕ 20	25, 50, 75, 100	700	1
ϕ 30	150, 200, 250		
ϕ 40	300		

Note 1: Custom stroke length is available per 1 mm increment.

Min. stroke length of type with switch

Rough sketch	Different surface installation		Same surface installation	
	Grommet	Terminal box	Grommet	Terminal box
Descriptions	Terminal box		Terminal box	
ϕ 20	15 (10) mm		32 mm (installation A) 80 mm (installation B)	
ϕ 30	15 (10) mm		30 mm	
ϕ 40	15 (10) mm		30 mm	

When one switch is installed, refer to the value in ().

Switch specifications

Descriptions	Proximity 2-wire			Proximity 3-wire	
	R1	R2	R2Y (2-color indicator type)	R3	R3Y (2-color indicator type)
Applications	Programmable controller, Relay, small solenoid valve		Programmable controller dedicated	Programmable controller, relay, IC circuit, solenoid valve	
Output method	—————			NPN output	
Power voltage	—————			4.5 V to 28 VDC	
Load voltage and current	85 V to 265 VAC 5 to 100 mA		10 to 30 VDC 5 to 30 mA	30 VDC or less	
				200 mA or less	150 mA or less
Light	LED (ON lighting)		Red/green LED (ON lighting)	LED (ON lighting)	Red/green LED (ON lighting)
Leakage current	1 mA or less with 100 VAC 2 mA or less with 200 VAC		1 mA or less	1.2 mA or less	10 μ A or less

Descriptions	Reed 2-wire			
	R0	R4	R5	R6
Applications	Relay, programmable controller	High capacity relay and solenoid valve	Programmable controller, relay, IC circuit (w/o light), serial connection	Programmable controller dedicated (with DC self hold)
Load voltage and current	12/24 VDC, 5 to 50 mA 110 VAC, 7 to 20 mA 220 VAC, 7 to 10 mA	110 VAC, 20 to 200 mA 220 VAC, 10 to 200 mA	5/12/24 VDC, 50 mA or less 110 VAC, 20 mA or less 220 VAC, 10 mA or less	24 VDC, 5 to 50 mA
Light	LED ON lighting	Neon light OFF lighting	None	LED ON lighting
Leakage current	0 mA	1 mA or less	0 mA	0.1 mA or less

Note 1: Refer to an Ending 1 page for other switch specifications.

Cylinder weight

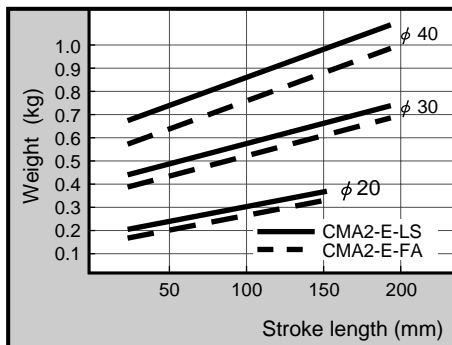

- SCP*2
- CMK2
- CMA2**
- SCM
- SCG
- SCA2
- SCS
- CKV2
- CA/OV2
- SSD
- CAT
- MDC2
- MVC
- SMD2
- MSD*
- FC*
- STK
- ULK*
- JSK/M2
- JSG
- JSC3
- USSD
- USC
- JSB3
- LMB
- STG
- STS/L
- LCS
- LCG
- LCM
- LCT
- LCY
- STR2
- UCA2
- HCM
- HCA
- SRL2
- SRG
- SRM
- SRT
- MRL2
- MRG2
- SM-25
- CAC3
- UCAC
- RCC2
- MFC
- SHC
- GLC
- Ending

Medium bore size cylinder
Standard type

How to order

Without switch

CMA2-E - **FA** - **20** - **25** ————— **M** **I**

With switch

CMA2-E - **FA** - **20** - **25** - **R0** - **R** - **M** **I**

A Mounting style

B Bore size

C Stroke length

■ Custom stroke length is available per 1 mm increment.

D Switch model no.

E Switch quantity

F Option

G Accessory
Note 2

⚠ Note on model no. selection

Note 1: Refer to page 206 for min. stroke length with switch.

Note 2: "I" "Y" can not be selected at the same time.

<Example of model number>

CMA2-E-FA-20-25-R0-R-MY

Model: Medium bore size cylinder, double acting, direct mounting

- A** Mounting style : Flange installation
- B** Bore size : ϕ 20 mm
- C** Stroke length : 25 mm
- D** Switch model no. : Reed R0 switch, lead wire 1 m
- E** Switch quantity : One on rod end
- F** Option : Piston rod material change
- G** Accessory : Rod clevis

Symbol	Descriptions
A Mounting style	
LS	Side foot mount
FA	Flange installation

B Bore size (mm)	
20	ϕ 20
30	ϕ 30
40	ϕ 40

C Stroke length (mm)		
Bore size	Stroke length Note 1	Custom stroke length
ϕ 20	1 to 700	By 1 mm increment
ϕ 30	1 to 700	
ϕ 40	1 to 700	

D Switch model no.					
Grommet Type	Terminal box type		Contact	Indicator	Lead wire
	Standard type	Splash-proof			
R1*	R1B	R1A	Proximity	1 color indicator type	2-wire
R2*	R2B	R2A		2 color indicator type	
R2Y*	R2YB	R2YA		1 color indicator type	3-wire
R3*	R3B	R3A	2 color indicator type		
R3Y*	R3YB	R3YA	Reed	1 color indicator type	2-wire
R0*	R0B	R0A		Without indicator light	
R4*	R4B	R4A		1 color indicator type	
R5*	R5B	R5A		Without indicator light	
R6*	R6B	R6A		1 color indicator type	

* Lead wire length	
Blank	1 m (standard)
3	3 m (option)
5	5 m (option)

E Switch quantity	
R	One on rod end
H	One on head end
D	Two
T	Three

F Option	
M	Piston rod material (stainless steel)

G Accessory	
I	Rod eye
Y	Rod clevis (pin and washer attached)

How to order discrete switch

● Switch body + mounting bracket

CMA2 - R0 - 40

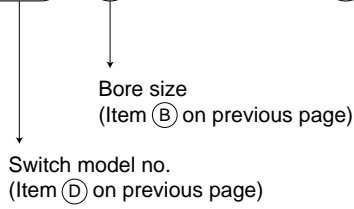

● Only switch body

SW - R0

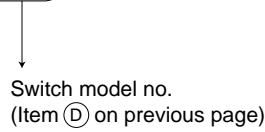

● Mounting bracket

CMA2 - R - 40

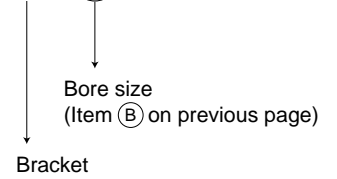

● Only terminal box

• For R* B

SW - RB

• For R* A

SW - RA

Internal structure drawing

This is the same as the standard type. Refer to Page 198.

SCP*2
CMK2
CMA2
SCM
SCG
SCA2
SCS
CKV2
CA/OV2
SSD
CAT
MDC2
MVC
SMD2
MSD*
FC*
STK
ULK*
JSK/M2
JSG
JSC3
USSD
USC
JSB3
LMB
STG
STS/L
LCS
LCG
LCM
LCT
LCY
STR2
UCA2
HCM
HCA
SRL2
SRG
SRM
SRT
MRL2
MRG2
SM-25
CAC3
UCAC
RCC2
MFC
SHC
GLC
Ending

Medium bore size cylinder
Standard type

Dimensions

- Side foot mount type (LS)
R type with switch

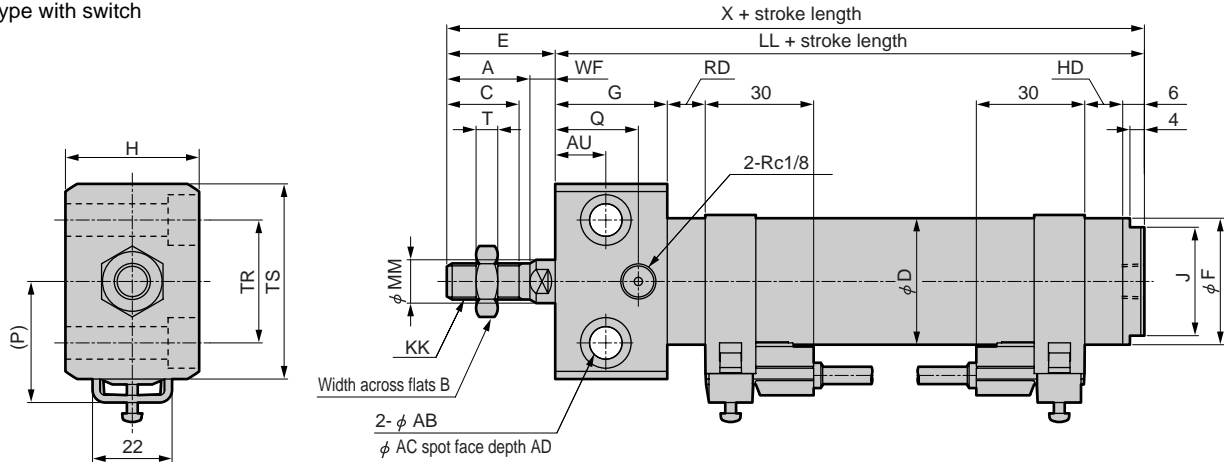

- Side foot mount type (LS)
R type switch terminal box

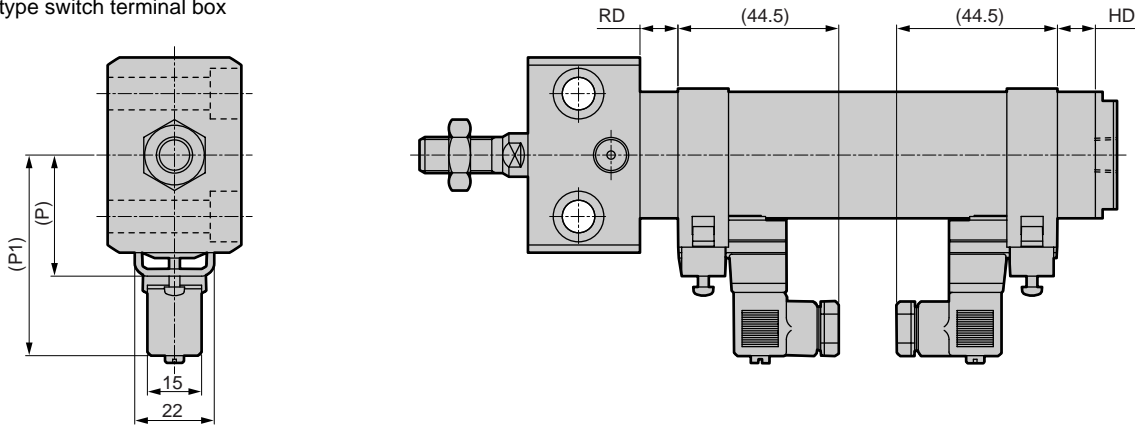

RD: Rod side max. sensitive position
HD: Head side max. sensitive position

Note 1: Refer to page 212 for dimensions of accessories.

Symbol	A	AB	AC	AD	AU	B	C	D	E	F	G	H	J	KK	LL	MM	Q	T	TR	TS
Bore size (mm)																				
φ20	20	6.6	11	6.5	9.5	13	18	25	31	26	28	28	22	M8 x 1.0	79	10	20	5	22	38
φ30	23	9	14	8.6	14	17	20	35	30	35	31	37	30	M10 x 1.25	88	12	23	6	34	54
φ40	25	11	17.5	10.8	15	19	22	45	31	46	32	48	41	M12 x 1.5	91	14	24	7	46	68
Symbol			With switch																	
Bore size (mm)	WF	X	HD	P	PI	RD														
φ20	11	110	7.5	28	48	7.5														
φ30	7	118	10.5	34	54	10.5														
φ40	6	112	11.5	39	59	11.5														

Dimensions

- Flange installation type (FA)
R type with switch

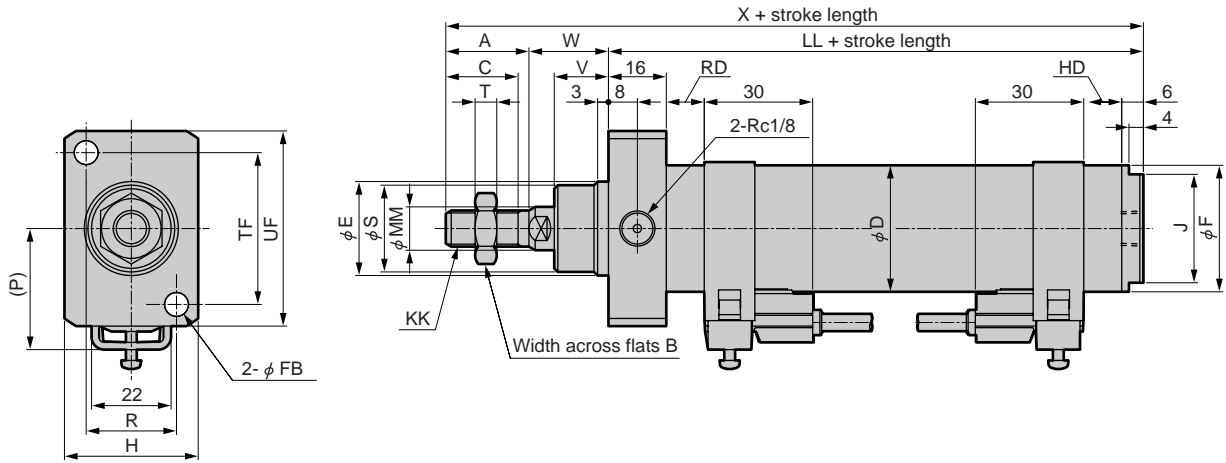

- Flange installation type (FA)
R type switch terminal box

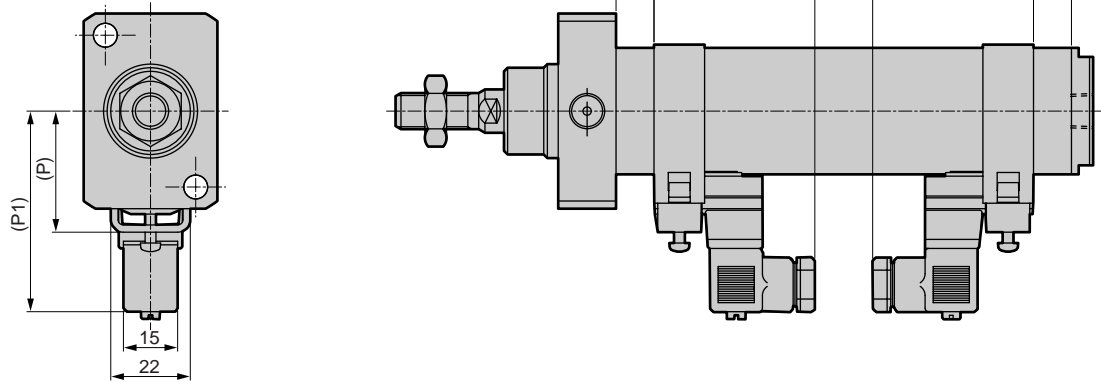

RD: Rod side max. sensitive position
HD: Head side max. sensitive position

Note 1: Refer to page 212 for dimensions of accessories.

Symbol	A	B	C	D	E	F	FB	H	J	KK	LL	MM	R	S	T	TF	UF	V
Bore size (mm)																		
φ20	20	13	18	25	18	26	5.5	28	22	M8 x 1.0	67	10	19	17	5	29	38	12
φ30	23	17	20	35	26	35	6.6	37	30	M10 x 1.25	73	12	25	24	6	42	54	15
φ40	25	19	22	45	26	46	9	48	41	M12 x 1.5	75	14	32	24	7	52	68	16
Symbol	W	X	With switch															
Bore size (mm)			HD	P	PI	RD												
φ20	23	110	7.5	28	48	7.5												
φ30	22	118	10.5	34	54	10.5												
φ40	22	112	11.5	39	59	11.5												

- SCP*2
- CMK2
- CMA2**
- SCM
- SCG
- SCA2
- SCS
- CKV2
- CA/OV2
- SSD
- CAT
- MDC2
- MVC
- SMD2
- MSD*
- FC*
- STK
- ULK*
- JSK/M2
- JSG
- JSC3
- USSD
- USC
- JSB3
- LMB
- STG
- STS/L
- LCS
- LCG
- LCM
- LCT
- LCY
- STR2
- UCA2
- HCM
- HCA
- SRL2
- SRG
- SRM
- SRT
- MRL2
- MRG2
- SM-25
- CAC3
- UCAC
- RCC2
- MFC
- SHC
- GLC
- Ending

Medium bore size cylinder
Standard type

CMA2 series common accessory dimensions

- SCP*2
- CMK2
- CMA2**
- SCM
- SCG
- SCA2
- SCS
- CKV2
- CA/OV2
- SSD
- CAT
- MDC2
- MVC
- SMD2
- MSD*
- FC*
- STK
- ULK*
- JSK/M2
- JSG
- JSC3
- USSD
- USC
- JSB3
- LMB
- STG
- STS/L
- LCS
- LCG
- LCM
- LCT
- LCY
- STR2
- UCA2
- HCM
- HCA
- SRL2
- SRG
- SRM
- SRT
- MRL2
- MRG2
- SM-25
- CAC3
- UCAC
- RCC2
- MFC
- SHC
- GLC
- Ending

● Rod eye (I)

Material: Steel

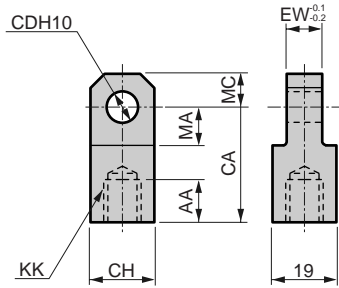

● Rod clevis (Y)

Material: Steel

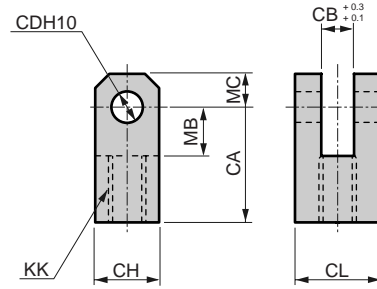

Note: Pin and washer are attached.

Model no.	Applicable tube Inner diameter (mm)	AA	CA	CD	CH	EW	KK	MA	MC	Mass (g)
M1-I-20	20	14	30	10 ^{+0.058} ₀	19	8	M8 x 1.0	13	10	60
M1-I-30	30	16	36	12 ^{+0.070} ₀	25	10	M10 x 1.25	16	12	106
M1-I-40	40	14	36	12 ^{+0.070} ₀	25	10	M12 x 1.5	16	12	100

Model no.	Applicable tube Inner diameter (mm)	CA	CB	CD	CH	CL	KK	MB	MC	Mass (g)
M1-Y-20	20	30	8	10 ^{+0.058} ₀	19	19	M8 x 1.0	13	10	99
M1-Y-30	30	36	10	12 ^{+0.070} ₀	25	25	M10 x 1.25	16	12	197
M1-Y-40	40	36	10	12 ^{+0.070} ₀	25	25	M12 x 1.5	16	12	193

● Clevis bracket (B2)

Material: Steel

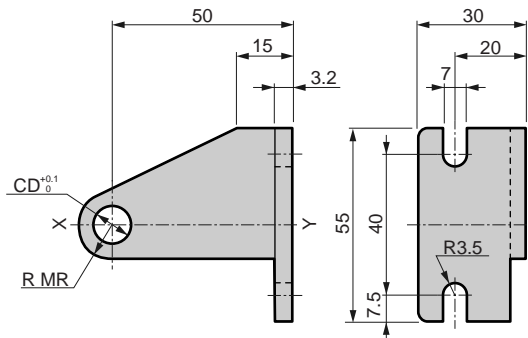

Note: The bracket symmetrical to the XY line is a pair.

Model no.	Applicable model	Applicable tube Inner diameter (mm)	CD	MR	Mass (g)
M1-B2-30-CA	CMA2-CA	20	10	11	158
M1-B2-40-CA	Clevis type	30, 40	12	11	162
M1-B2-20-TA	CMA2-TA/TB	20	8	8	132
M1-B2-30-TA	Trunnion type	30, 40	10	11	142

Note: Model above includes a snap ring and a pin.
(Not attached for trunnion type).

● Pin for clevis bracket (P2)

Material: Steel

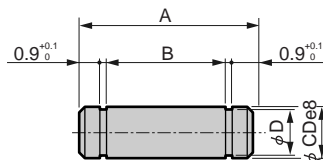

Model no.	Applicable tube Inner diameter (mm)	A	B	CD	D	Used snap ring	Mass (g)
M1-P2-20	20	25	20	10 ^{-0.025} _{-0.047}	9	E type 9	16
M1-P2-30	30, 40	27	22	12 ^{-0.032} _{-0.059}	9	E type 9	24

Note: For bracket type, pin and split pin are attached to the product.
(Not attached for trunnion type).

● Pin for rod clevis (P)

Material: Steel

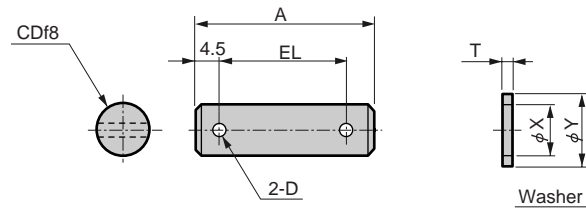

Model no.	Applicable tube Inner diameter (mm)	A	D	CD	EL	T	X	Y	Mass (g)
M1-P-20	20	37	4	10 ^{-0.013} _{-0.035}	28	2	10.5	18	29
M1-P-30	30, 40	46	4	12 ^{-0.016} _{-0.043}	37	2.5	13	21	50

Note: For rod clevis type, pin and split pin are attached to the product.